

# penelope

by Aaton

Aaton 35mm 2-Perf & 3-Perf motion picture camera

User's guide v1.33 (rev.1)

Aug. 19 2010

<b>General overview</b>	<b>7</b>
Front view	8
Rear view	9
Assistant's side	10
Assistant's controls	11
Assistant's controls - detailed view	12
Operator's side	13
Top view	15
<b>Getting started</b>	<b>16</b>
Power up the camera electronics	17
Power up the VHR video-assist	17
Power down the camera electronics and video-assist	17
The «set» key	17
TEST mode	18
Adjusting the Aatonite (glow)	18
Film camera status	19
Warning messages	20
Magazine footage adjustment	21
Foot or meter setting	21
Footage counting	21
Manual footage counter	22
Video-assist direct access	22

<b>Camera body</b>	<b>23</b>
<b>2.1 Lenses</b>	<b>24</b>
The PL lens port	24
The PV lens port	24
i/lenses compatibility	24
<b>2.2 Viewing System</b>	<b>25</b>
Eyepiece	25
Attaching the finder extension	25
Viewfinder tension adjustment	26
Adjusting the viewing horizon	26
Adjusting the diopter	27
The eyepiece shutter	27
Viewing screen	27
Changing the viewing screen	28
Adjusting the viewing screen	28
<b>2.3 The variable shutter</b>	<b>29</b>
Concept	29
Adjusting the shutter	29
<b>2.4 Film gate and pulldown claw</b>	<b>30</b>
Adjusting the pitch	30
The side pressure bar	30
The film gate	30

<b>2.5 Camera power</b>	<b>31</b>
Installing batteries	31
Charging the batteries	32
Other power sources	32
<b>2.6 Motors</b>	<b>33</b>
Film frame-rate	33
Using external speed control	34
<b>2.7 Assistant's side LCD control panel and jog</b>	<b>34</b>
The jog	34
Basics: «sync», «var», «iso», «mag»	35
AatonCode initialization	35
Timecode generator	36
ISO setting	37
SYNC speed	37
VAR speed	37
EXT speed	38
EXT SYNC speed	38
Low battery alert	39
Technical menu	39
LEMO start mode	40
Video Out menu	40
System Time	41
Adjusting the low-battery alert level	41
Display contrast adjustment	42
External Sync	42
Footage Mode	42

Software Version	43
Lens Data	43
Video-assist proxies	43
Firmware Install	44
Slow Start	45
No Film Mode	45
<b>2.8 Operator's side settings</b>	<b>46</b>
<b>2.9 Cold weather tips</b>	<b>47</b>
<b>Magazine</b>	<b>48</b>
<b>3.1 Concept</b>	<b>49</b>
<b>3.2 Pressure plate system</b>	<b>49</b>
Claw rear pressure plate	49
Picture rear pressure plate	49
<b>3.3 Loading the film (in 17 steps)</b>	<b>50</b>
In the light	50
In the dark	51
Still in the dark	52
Still in the dark	53
In the light again	54
Installing the magazine	55
Removing the magazine	55

<b>Video-assist</b>	<b>56</b>
4.1 Image look (Video menu)	57
• Gain	58
• <b>Color temp.</b>	<b>58</b>
• <b>Color saturation</b>	58
• <b>Color bars</b>	58
• <b>Color/B&amp;W out</b> (Output).	58
4.2 Frame & mask	<b>59</b>
4.3 Proxies capture	<b>60</b>
4.4 Metadata insert	<b>61</b>
• AatonCode	61
• Battery voltage	61
• VITC line & parity (not yet functional)	61
• Lens Data	61
• Film status	62
• Software/hardware	62
4.5 Logos	<b>62</b>
<b>Technical drawings</b>	<b>63</b>

# General overview



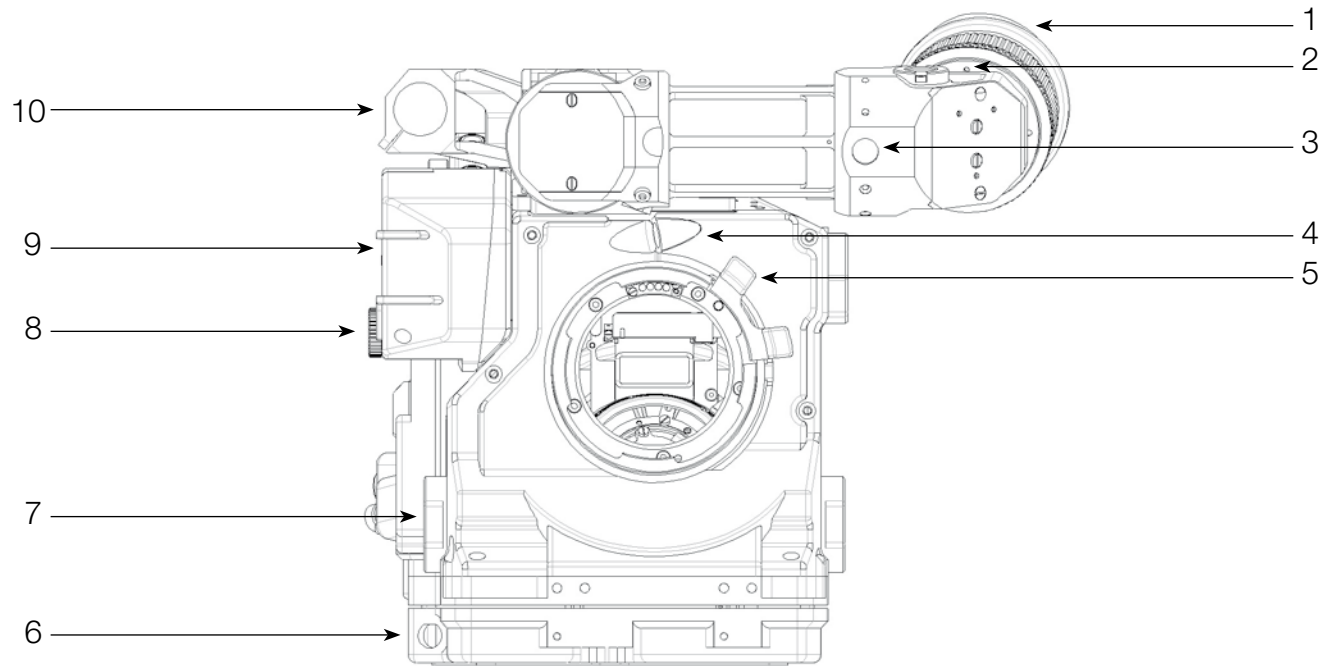

**Front view**

- |                                  |   |
|----------------------------------|---|
| <b>1 Short eyepiece</b>          | (Extension eyepiece to be ordered separately) |
| <b>2 Horizon setting knob</b>    | To adjust the image horizon                   |
| <b>3 Friction adjusting ring</b> | To adjust the tension of the eyepiece swivel  |
| <b>4 Fischer-2 connector</b>     | Eyepiece heating cable connector              |
| <b>5 PL mount locking ring</b>   | Lock ring for 35mm PL mounted lenses          |
| <b>6 LEMO-2 connector</b>        | Run/Stop connector                            |
| <b>7 Rosette</b>                 | For accessories compatible with ARRI rosettes |
| <b>8 Video (VHR) ND knob</b>     | To adjust the video light level               |
| <b>9 Video housing</b>           | Protects the CCD unit                         |
| <b>10 Top rod holder</b>         | To install a rod (15, 15.8 or 19mm)           |



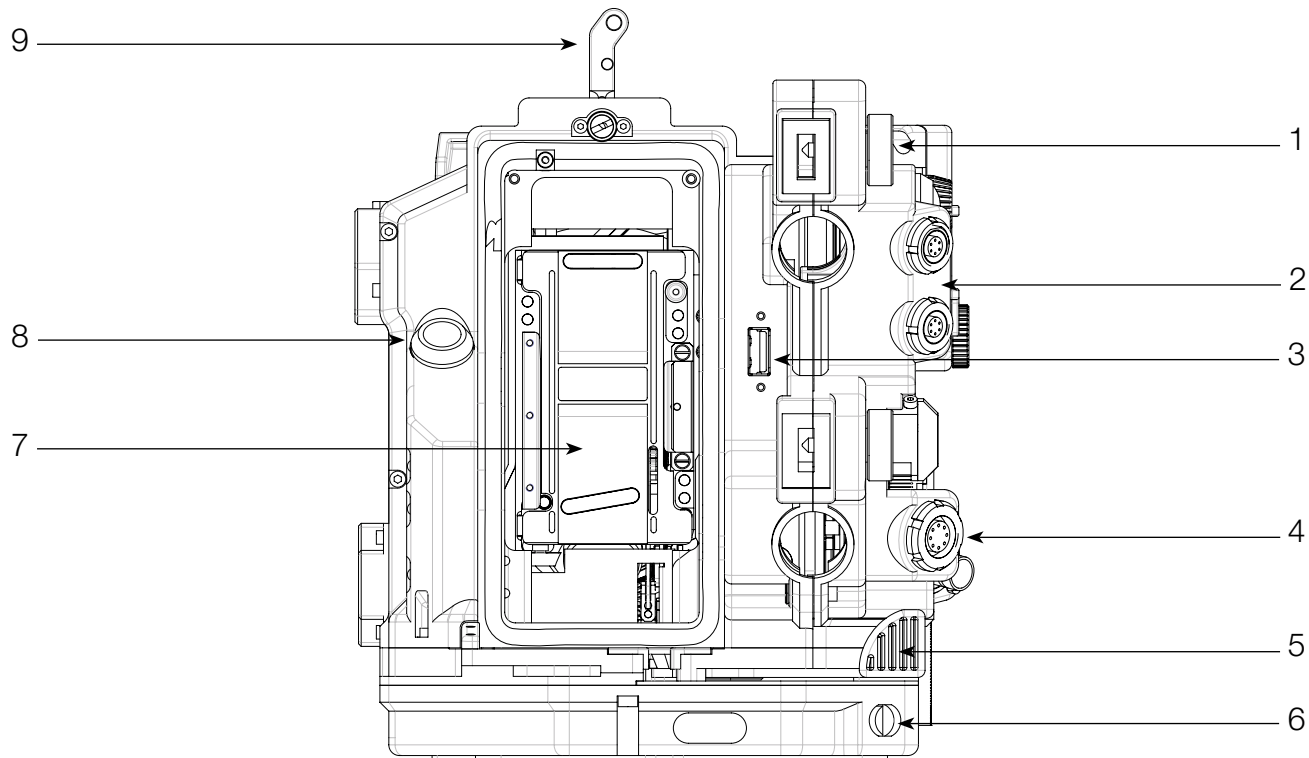

**Rear view**

- |                                      |  |
|--------------------------------------|--|
| <b>1 Upper battery locking screw</b> | Fastens the upper onboard battery                          |
| <b>2 LEMO-6 socket (x2)</b>          | Provides +Batt, Start and Ground for accessories           |
| <b>3 USB socket</b>                  | Connects to a USB key                                      |
| <b>4 LEMO-8 socket</b>               | Provides 12V, Start, Sync pulse and ground for accessories |
| <b>5 Magazine release lever</b>      | Used to release the magazine from the camera body          |
| <b>6 LEMO-5 socket</b>               | Timecode communication                                     |
| <b>7 Gate</b>                        | Removable gate, 2-Perf or 3-Perf                           |
| <b>8 Run/Stop switch</b>             | Runs/stops the film  |
| <b>9 Magazine locking lever</b>      | Secures the magazine to the camera body                    |

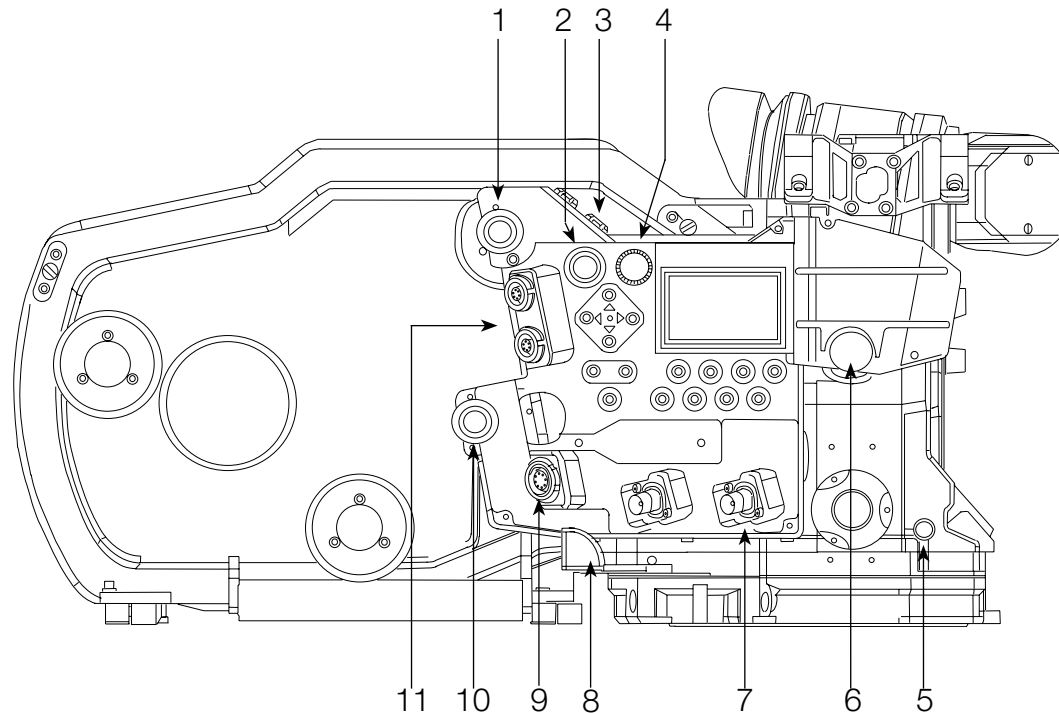

**Assistant's side**

- |                                       |  |
|---------------------------------------|--|
| <b>1 Upper battery locking screw</b>  | Fastens the upper onboard battery                          |
| <b>2 Run/Standby switch</b>           | Runs and stops the film shooting                           |
| <b>3 Fischer-4 socket</b>             | Provides power and composite video signal for MiniMonitors |
| <b>4 Jog wheel</b>                    | Modifies camera parameter settings                         |
| <b>5 Pitch control</b>                | Adjusts the claw pulldown stroke                           |
| <b>6 Video (VHR) ND knob</b>          | Adjusts the video light level                              |
| <b>7 BNC connectors (x2)</b>          | Provide video output                                       |
| <b>8 Magazine release lever</b>       | Unlocks the magazine from the camera body                  |
| <b>9 LEMO-8 socket</b>                | Provides +Batt., Start, Sync and Ground for accessories    |
| <b>10 Lower battery locking screw</b> | Fastens the lower onboard battery                          |
| <b>11 LEMO-6 socket (x2)</b>          | Provides +Batt., Start and Ground for accessories          |

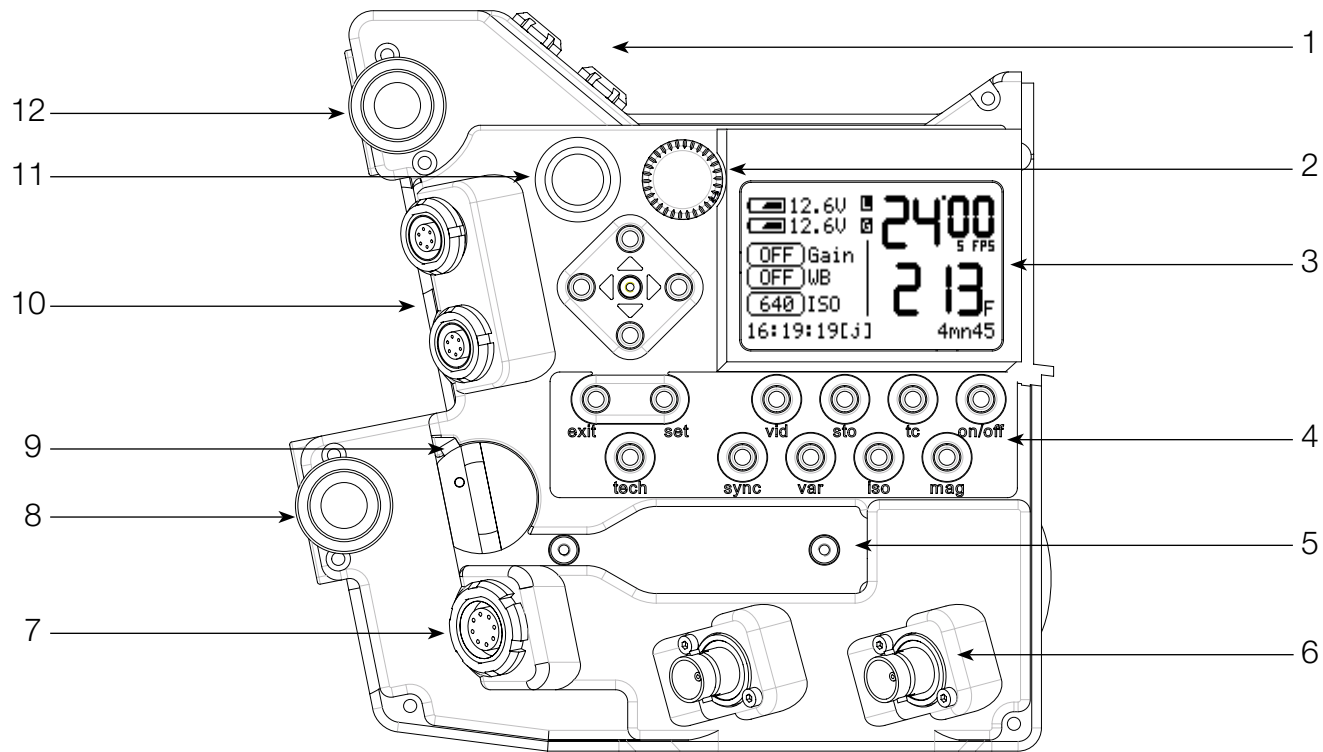

### Assistant's controls

- |    |                                     |   |
|----|-------------------------------------|---|
| 1  | <b>Fischer-4 socket</b>             | Provides power and composite video signal for MiniMonitors (IVS compatible) |
| 2  | <b>Jog wheel</b>                    | Camera parameters settings  |
| 3  | <b>LCD screen</b>                   | Displays camera and video parameters  |
| 4  | <b>Setting keys</b>                 | Allows access to camera and video operating menu                            |
| 5  | <b>Ethernet connector (RJ45)</b>    | Computer communication  |
| 6  | <b>BNC sockets</b>                  | Video outputs   |
| 7  | <b>LEMO-8 socket</b>                | +Batt., Start, Sync and Ground for accessories                              |
| 8  | <b>Lower battery locking screw</b>  | Fastens the lower onboard battery   |
| 9  | <b>Ethernet cable locking lever</b> | Locks Ethernet cable  |
| 10 | <b>LEMO-6 socket (x2)</b>           | Provides +Batt., Start and Ground for accessories                           |
| 11 | <b>Run/Stop switch</b>              | Runs/stops the film   |
| 12 | <b>Upper battery locking screw</b>  | Fastens the upper onboard battery   |

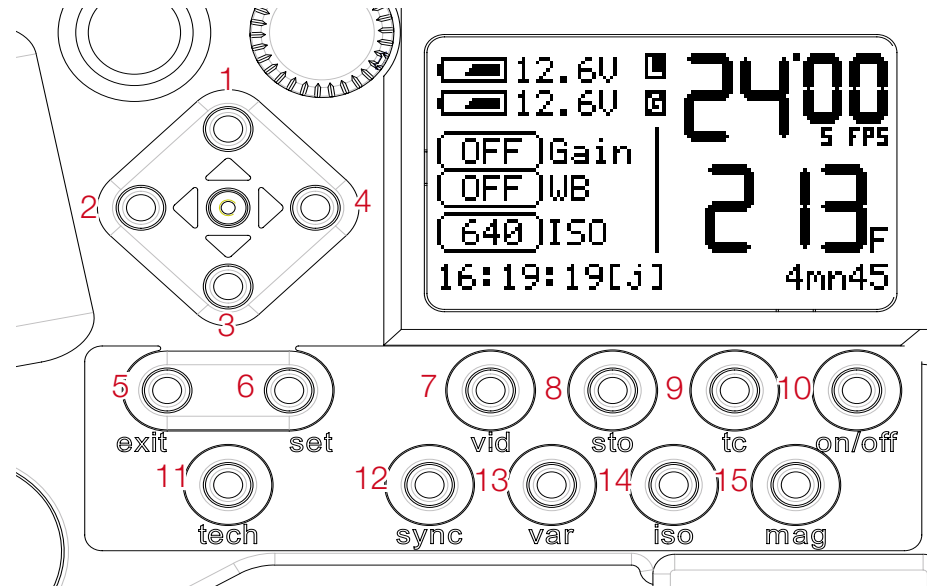

### Assistant's controls - detailed view

- |                 |   |
|-----------------|---|
| 1 «up» key      | scroll video-assist and film camera setups (direct access to video-assist's gain) |
| 2 «left» key    | scroll video and camera setups (direct access to shutter phasing)                 |
| 3 «down» key    | scroll video and camera setups (direct access to video-assist's gain)             |
| 4 «right» key   | scroll video and camera setups (direct access to shutter phasing)                 |
| 5 «exit» key    | confirm setup menu  |
| 6 «set» key     | select functions  |
| 7 «vid» key     | access video-assist setups («set» + «vid» activate monitor display)               |
| 8 «sto» key     | access Framestore page  |
| 9 «tc» key      | access Timecode page  |
| 10 «on-off» key | apply power to film camera electronics («set» + «on-off» activate video-assist)   |
| 11 «tech» key   | access Technical page   |
| 12 «sync» key   | access synch speed settings («set» + «sync»)                                      |
| 13 «var» key    | access variable speed settings («set» + «var») and external speed control         |
| 14 «iso» key    | access ISO and magazine IDs («set» + «iso»)                                       |
| 15 «mag» key    | access magazine footage settings («set» + «mag»)                                  |

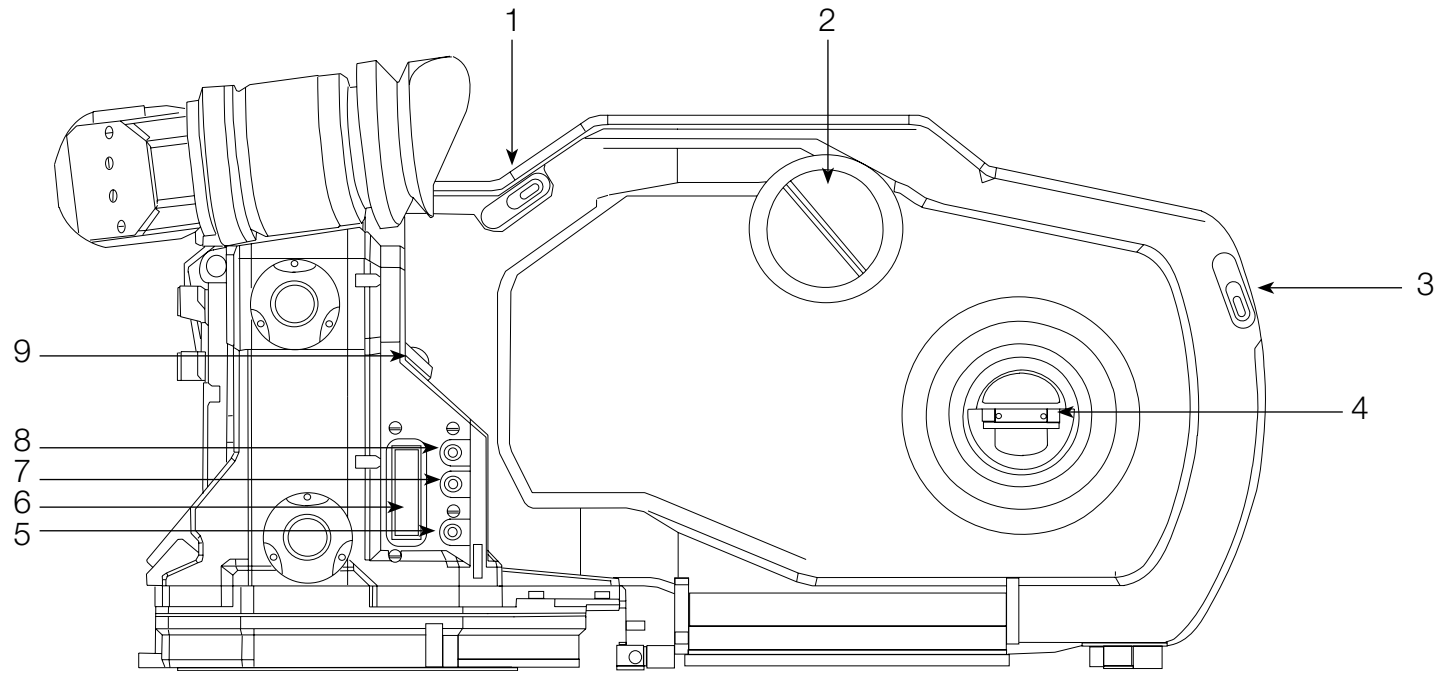

### Operator's side

- |   |                                    |  |
|---|------------------------------------|--|
| 1 | <b>Magazine door locking lever</b> | Locks/unlocks magazine door                  |
| 2 | <b>Magazine footage counter</b>    | Manually checks magazine footage             |
| 3 | <b>Magazine door locking lever</b> | Locks/unlocks magazine door                  |
| 4 | <b>Take-up spool inching knob</b>  | Adjusts loop size while loading the magazine |
| 5 | <b>Lower display key</b>           | Modifies camera parameters                   |
| 6 | <b>Operator's LCD display</b>      | Displays camera speed and magazine footage   |
| 7 | <b>Middle display key</b>          | Modifies camera parameters                   |
| 8 | <b>Upper display key</b>           | Modifies camera parameters                   |
| 9 | <b>Run/Stop switch</b>             | Runs/stops the film                          |

LCD display - Assistant's side

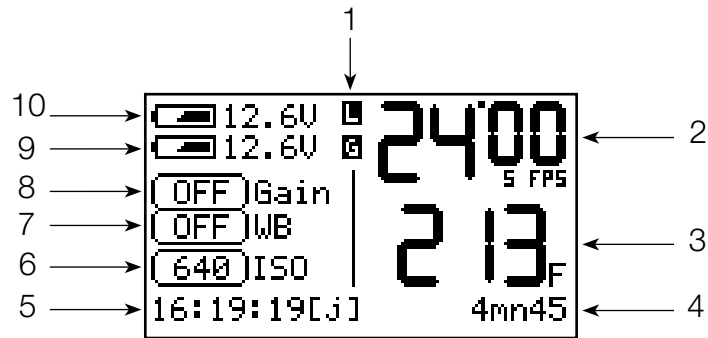

LCD display - Operator's side

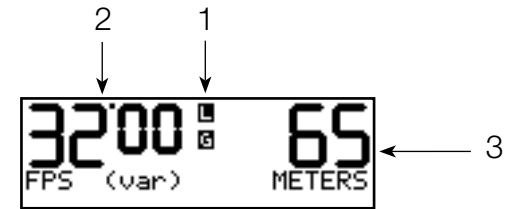

- 1 L (mag upper lever) and G (gate) flags
- 2 Selected speed
- 3 Magazine footage
- 4 Remaining time (minutes and seconds)
- 5 Time code
- 6 Film ISO
- 7 Video-assist white balance
- 8 Video-assist gain
- 9 Lower battery meter
- 10 Upper battery meter

- Symbols blink - error (magazine upper lock or gate)
- Sync/Var./Ext. frame-rate (thousandths not displayed)
- Remaining or elapsed footage, in feet or meters
- Magazine remaining running time
- Hour : minute : second [initialization]
- ISO for correct AatonCode matrix exposure
- 5600°K, 3200°K and Assistant entered values
- Current gain setting
- Lower battery voltage
- Upper battery voltage

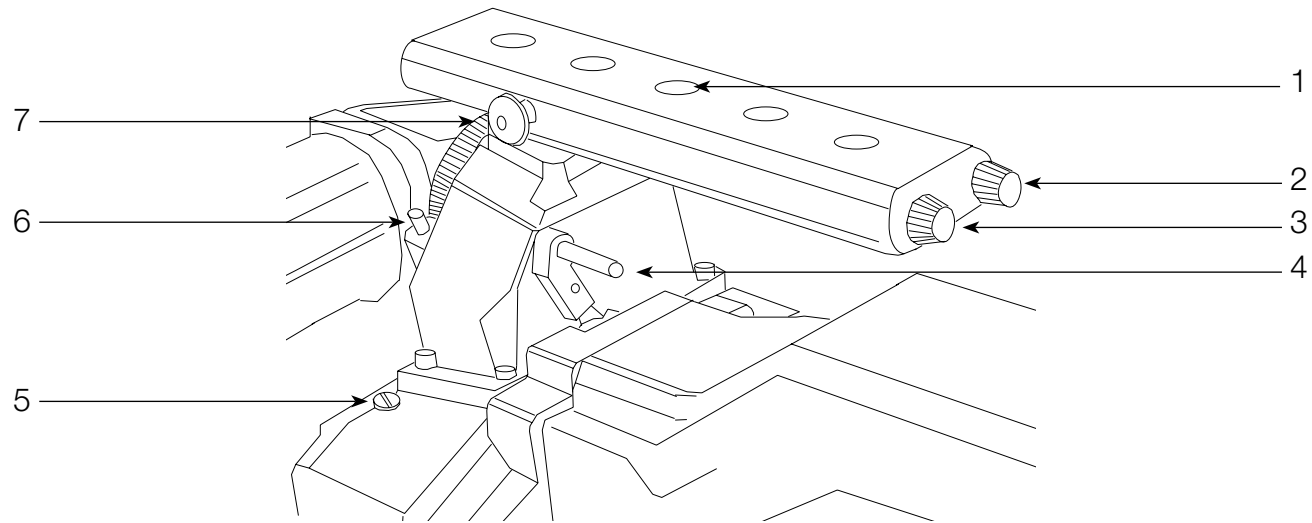

**Top view**

- |   |                                  |   |
|---|----------------------------------|---|
| 1 | <b>3/8" inserts</b>              | Socket for accessories                              |
| 2 | <b>«Sh» tool</b>                 | Shutter angle adjustment tool                       |
| 3 | <b>«Pitch» tool</b>              | Pulldown pitch adjustment tool                      |
| 4 | <b>Magazine's upper lock</b>     | Secures the magazine to the camera body             |
| 5 | <b>Collimation cap</b>           | Gives access to ground glass collimation adjustment |
| 6 | <b>Viewfinder friction screw</b> | Adjusts the viewfinder up-down freedom of movement  |
| 7 | <b>Tape hook</b>                 | Holds the focus distance tape on the gate plane     |

1

Getting started





### Power up the camera electronics

To turn ON the camera electronics, press the «on/off» key.

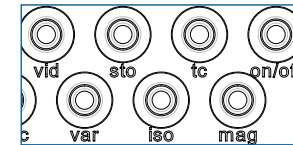

### Power up the VHR video-assist

To turn ON the video-assist, press the «set» key and then the «on/off» key.

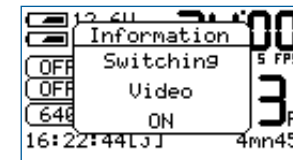

### Power down the camera electronics and video-assist

Press the «on/off» key, a window appears on the LCD screen. Hold the «on/off» key, a bargraph timer starts counting down.

When finished, the screen displays **Au revoir**.

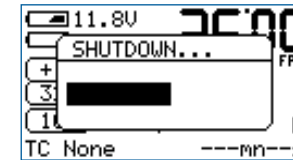

### The «set» key

The «set» key gives access to the camera's settings. While pressing the «set» key, a window appears for a few seconds allowing you to access the desired parameters.

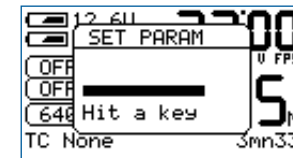

## TEST mode

The **TEST** mode lets you open the shutter and keep it protected inside the camera body. This is used to check the gate for cleanliness and to find the image while doing a steadiness test. This lets you find the correct film/perf position for the second film passage if you are using the double exposure method.

To access the **TEST** mode, press the «Run/Stop» switch (**A**) – located on both the Assistant’s and Operator’s sides – and hold it pressed for 3 to 4 seconds. When the shutter opens, the display background color turns dark blue, release the switch.

If you want to inch the film frame by frame, press the upper key (**C**) located on the Operator’s side. To leave the **TEST** mode, press the «Run/Stop» switch again for 3 to 4 seconds.

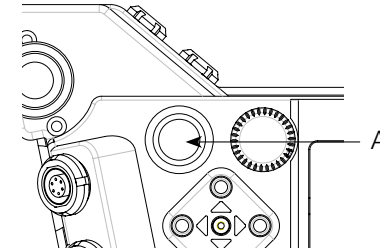

## Adjusting the Aatonite (glow)

The viewing screen carries illuminated markings referred to as Aatonite. The brightness level is user adjustable using the middle (**B**) or upper (**C**) keys located on the Operator’s side.

The configuration of these markings is different from one screen to another (see the screen illustrations, Chapter 5).

**NOTE:** the brightness level can also be adjusted while the film is running.

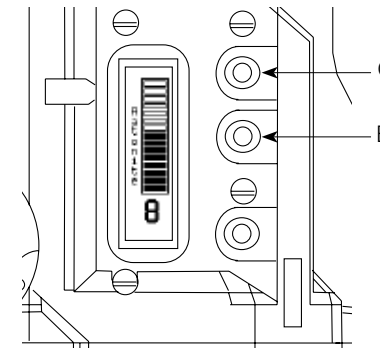

## Film camera status

The LCD screen color informs the camera crew about the shooting status:

### Light cyan

The camera is in **STANDBY**.

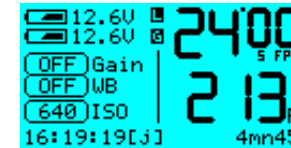

### Orange

The camera is in **RUN**, but has not yet reached the selected speed.

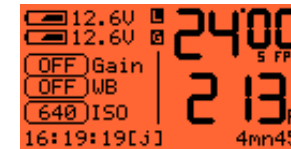

### Green

The camera is in **RUN** at the selected speed.

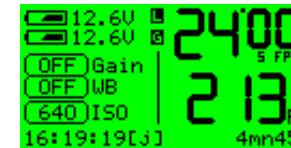

### Purple

The camera is at end of film

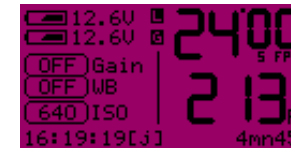

### Red

A problem has been detected, e.g. film jam.

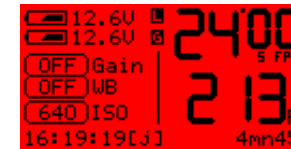

## Warning messages

When a problem has been detected, the LCD screen's background turns red followed by an explanatory message.

### Gate position

The camera gate is easily removable to allow switching between 2-Perf and 3-Perf formats. The correct positioning of the gate is mandatory for proper camera functioning and focused pictures. The camera gate holder is equipped with 4 sensors to check the gate position; if the gate is not properly positioned, the camera displays the message **GATE MISPLACED** and *refuses to run*. Remove the gate and reinstall it.



### Magazine upper lock lever

The magazine top locking lever, located on top of the camera body, insures the magazine's proper positioning. It is equipped with a position sensor which does not allow the camera to run if this lever is unlocked; the message **MAG NOT LOCKED** is displayed and the camera *refuses to run*. Lock the lever and press RUN.

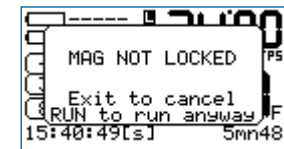

## Magazine footage adjustment

An embedded RFID chip identifies each magazine.

It enables associating a letter (A - J) with each magazine, allowing the film speed and remaining footage to follow each magazine.

Press the «set» key and the «iso» key to enter the **ISO** menu, then press the «left» or «right» key to select the desired letter.

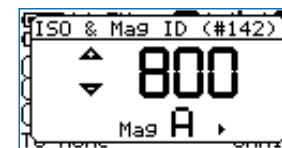

Press the «set» key, then the «mag» key to access the **MAG** menu. If a full 400ft roll has been loaded, press the «mag» key two times to adjust the footage to 400ft (122m). If you load a short end in the magazine, check the length with the magazine footage counter and enter the same value into the **MAG** menu by pressing the «up» or «down» key.

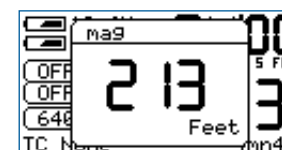

This value is stored for each RFID magazine, identified by a letter from A to J.

## Foot or meter setting

While in the **Mag** menu, press the «left» or «right» key to select the desired measuring unit.

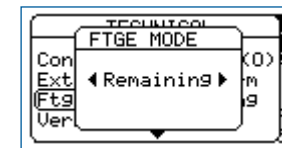

## Footage counting

Penelope can display either the remaining or the elapsed footage.

To select the mode, press the «set» key then the «tech» key to open the **Technical** Menu.

Press the «down» key to select the **Ftg Mode** item and press the «right» key to access it. Choose between **Remaining** or **Elapsed** by pressing the «left» or «right» key. Press the «set» to validate your selection, then «exit».



### Manual footage counter

Measure the remaining footage by rotating the mechanical footage indicator (located on the door) counterclockwise.

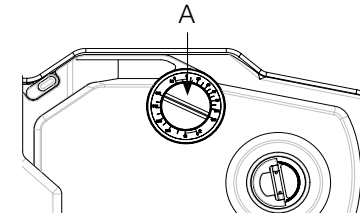

### Video-assist direct access

#### Video gain

The video-assist gain is directly accessible through the control panel. Press the «up» or «down» key to change the video gain. Wait for 3 seconds or press the «set» key to validate. The adjustment range is -10dB to +12dB, in 1dB steps.

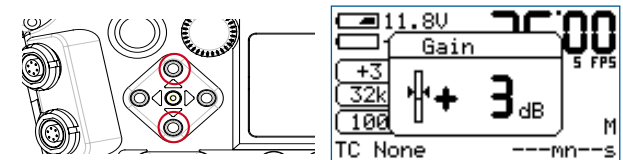

### White Balance

Press the «set» key, then the «right» key to activate the **Auto White Balance**. If there's too much light (or not enough), the message **Too Bright** or **Too Dark** is displayed. When the white balance is correct, **OK** is displayed.

**NOTE:** The video-assist switches automatically to the User's Color Temperature mode. The stored RGB values can be modified in the Video Menu, see Chapter 4.

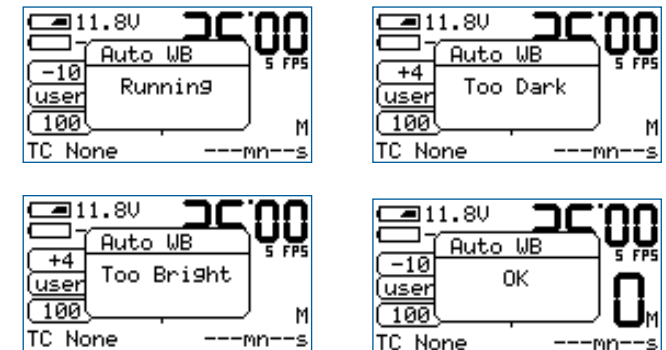

2

Camera body



## 2.1 Lenses

### The PL lens port

The PL lens port is the standard mounting system delivered with Penelope and allows the use of all 35mm ARRI PL mounted lenses.

### The PV lens port

The PV lens port is the standard mounting system for the Panavision cameras, it can be installed on Penelope.

### Installing the lens

To install the lens on the camera body, turn the outer locking ring counter-clockwise until it stops. If the port cap is on, remove it. Align the four protruding flanges on the lens with the four corresponding cutaways in the locking ring and insert the lens into the camera port so that its flanges rest evenly against the lens seat. Tighten the locking ring by turning it clockwise until the lens is secured and the locking ring is set firmly. Make sure the locking ring is tight enough so that it cannot be inadvertently unlocked.

### i/lenses compatibility

In order to display the data coming from a Cooke/i lens on both the camera display and the video monitor, press the «set» key then the «tech» key to open the **Technical** menu. Select the **Lens Data** item and press the «right» key to access it. With the «right» key, select **Rx ON** or **Rx OFF**. Press «set» to validate the selection. If **ON** is selected, the data will be displayed.

### Flange focal distance.

Refers to the critical distance from the lens seat to the film plane. With the PL port, the precise FFD of Penelope is 52mm -30 to -40 microns as measured with a depth gauge in the lens port. With the PV port, the FFD is 57.15mm -45 to -55 microns.

It is recommended that these tolerances be checked and maintained by a qualified technician. The combination of FFD and back focus distance of a lens directly affect the precise focus (and resulting image sharpness). Make sure these critical measurements are strictly upheld. When using an unfamiliar lens for the first time, check that the eye focus matches the tape-measured focus marks on the lens, and/or shoot a focus test.

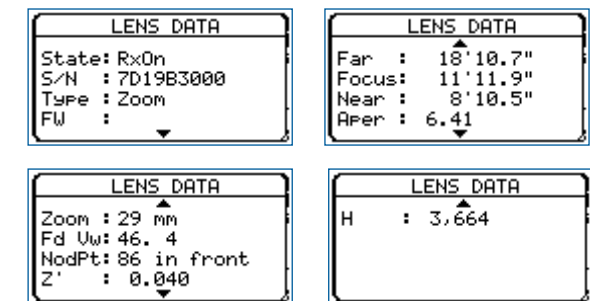



## 2.2 Viewing System

### Eyepiece

Penelope viewfinder is designed to be fully orientable, providing left or right side viewing and upright image in any position. The viewfinder arm is equipped with an eyepiece that can be used for handheld and tripod operation.

The eyepiece can be equipped with a heating system which receives its power from a cable connected to the Fisher-2 socket, located on the camera front body, above the lens mount.

### Attaching the finder extension

For dolly work, an optical extension (280 mm) can be inserted between the viewfinder arm and the eyepiece.

First remove the eyepiece by rotating the locking ring **(A)** clockwise until it reaches its stop and gently pull the eyepiece. To install the finder extension, align its four protruding flanges with the four corresponding cutaways in the viewfinder locking ring and insert it into the viewfinder port so that its flanges rest evenly against the lens seat. Tighten the locking ring by turning it counterclockwise until the extension finder is secured in place and the locking ring is firmly set. Install the eyepiece on the finder extension.

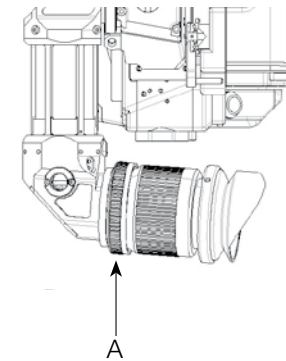

### Viewfinder tension adjustment

The screw (B) at the base of the viewfinder, allows you to modify the viewfinder left/right lateral friction. Turn counterclockwise to increase the friction. Turning this screw until it reaches its stop, locks the viewfinder's left/right movement.

The friction adjusting knurled screw (C), located on the front of the viewfinder, can be used to adjust the tension of the eyepiece swivel, depending on the Operator's preference and on the type of viewfinder being used. When using the standard eyepiece, tension should be relatively light to allow for movement with a moderate amount of pressure. When using a finder extension, tension should be increased to support the additional weight.

To adjust the tension of the swivel, rotate the knurled screw (C), clockwise to increase tension and counterclockwise to decrease tension.

### Adjusting the viewing horizon

If the rotation of the image seen through the camera's viewfinder does not exactly match what is seen with the naked eye, there is a fine adjustment that can be made to the image's relative horizon. Find the knurled knob (D) located on top of the viewfinder. While looking through the viewfinder, turn the knob in order to adjust the image's upright position.

**NOTE:** the knob needs to be turned 180° when installing an eyepiece extension.

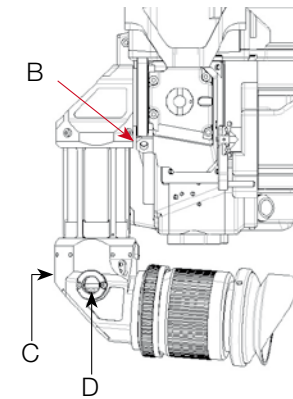

### Adjusting the diopter

Before shooting, the diopter setting of the viewfinder should be adjusted to the Operator's eye. To set the diopter, use the diopter set ring (E) located on the short eyepiece.

Look through the viewfinder while rotating the diopter set ring until the edge of the viewing screen cross-hair is in sharp focus. It is recommended to perform this adjustment with the port cover off and no lens on the camera.

**NOTE:** the diopter set ring is engraved with numbers and dots. Use them to quickly recall your particular setting when more than one person is looking through the viewfinder.

### The eyepiece shutter

To prevent light from leaking through the viewfinder, the eyepiece shutter must be closed any time the camera is running film and the Operator's eye is away from the eyepiece.

To close or open the eyepiece shutter, use the small silver lever located on the eyecup ring (F).

### Viewing screen

The viewing screen (ground-glass) is interchangeable. Viewing screens for 2-Perf and 3-Perf formats can be selected in «Viewing Screens List», Chapter 5.

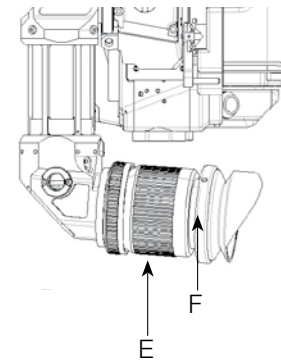

## Changing the viewing screen

The viewing screen can easily be removed by the user. First remove the port cap. Remove the battery (s) and clear the mirror shutter so that it is positioned safely inside the body by rotating it close to its center shaft with your finger. Look into the port and look at the screen directly above the aperture gate (**G**). Get a piece of Post-it, that will take-out the viewing screen without dirtying it. Put the Post-it on your forefinger, the sticky part of it facing up. Smoothly put a finger on the viewing screen, and remove it.

To reinstall the screen, look into the port and locate the right and left lip of the viewing screen holder. Gently push the screen straight into the holder, aligning the two white marks of both holder and screen. Proceed as before, with a piece of Post-it on your finger.

## Adjusting the viewing screen

The image focus on the viewing screen (ground-glass) should match the lens barrel focus mark and the focus on the film. Before adjusting the viewing screen, be certain that the flange focal distance of the camera is set according to the manufacturer specifications.

To proceed, you must unscrew and remove the cap (**H**) located on the Operator upper side of the camera body. The open hole gives access to the screen holder that you can up and down move by turning its Allen screw (2mm Allen key).

Set a focusing chart at a known distance. Adjust the focus mark of the lens to the same distance. Get a sharp image on the ground-glass by moving the holder up or down with the Allen key. Double check the focus of the viewing screen using the focus ring of the lens. If the image is still not sharp, perform this operation again.

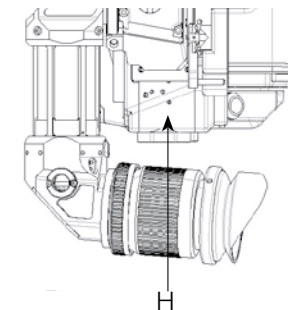
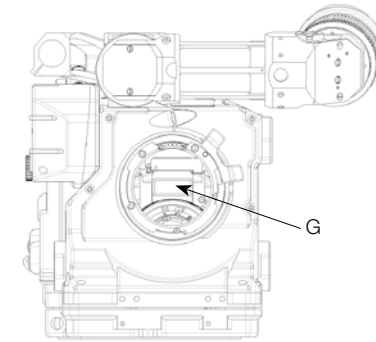

## 2.3 The variable shutter

### Concept

The reflex mirror shutter diverts the lens rays to the viewing screen while the claw pulls the film down to the next unexposed film frame. It is made of a 180° glass mirror, and a 180° black metallic shutter hidden underneath the mirror. The metallic shutter can be slid (un-hidden) to four-positions which make for 180°, 178°, 150°, 144° shutter opening angles.

### Adjusting the shutter

To adjust the shutter opening angle, unscrew the tool marked **Sh** located in the rear of the carrying handle. Make sure the battery has been removed from the camera, remove the lens port cap.

Locate the tool guiding hole to the lower right of the inside lens holder. Gently rotate the shutter at its base with your finger until the brass driving gear is centered underneath the tool guiding hole.

Insert the **Sh** tool through the guiding hole and into the brass gear. Rotate the tool until the appropriate notched angle setting is reached ; turning counter-clockwise reduces the shutter opening, turning clockwise increases the opening.

A shutter blade carrying the angle values is visible at the left edge of the mirror. Make sure the white line to the immediate right of the 172.8°, 150° and 144° markings meets the left edge of the mirror.

When the adjustment is done, remove the tool and store it back in the carrying handle.

### Always unplug the power

Each time you have to put a finger inside the camera body, you must remove the battery. If by mistake the camera starts running while your finger is touching the mirror shutter, the mechanism can be seriously damaged (and your finger too).

### Shutter angles

- 180° for filming 25fps under 50Hz HMI lighting, and 24fps under 60Hz.
- 172.8° for filming at 24fps under 50Hz HMI lighting.
- 150° for filming at 25fps under 60Hz HMI lighting.
- 144° for filming an NTSC monitor at 24fps while minimizing the roll bar visibility.

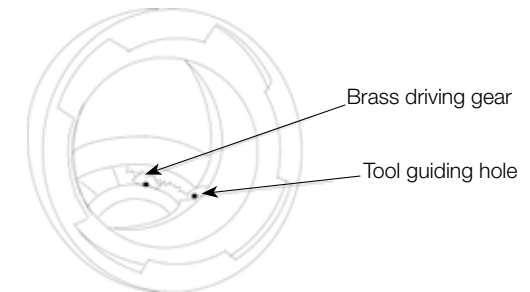

## 2.4 Film gate and pulldown claw

### Adjusting the pitch

To adjust the pitch, use the **Pitch** tool located in the camera carrying handle.

Remove the pitch protector cap (**A**) located on the Assistant's side near the **Pitch** label. Insert the tool inside the opening.

You will *feel* a screw that you need to turn counterclockwise until it stops; the pulldown pitch is now at its maximum.

Put a loaded magazine on the camera, and while keeping the tool in its position run the camera, it will run with a *clicking noise* caused by the claw slamming into the edge of the perf too hard.

Turn the tool clockwise until you hear a *purring* sound. Once you have reached this setting, turn the tool counterclockwise by about 20°; this will accommodate any variation of the film pitch that occurs between different film stocks or under humid and hot weather conditions.

**NOTE:** Make this adjustment with the film stock you will be using.

### The side pressure bar

The film gate also features a side pressure bar (**B**) at the level of image exposure to insure maximum lateral steadiness.

### The film gate

Penelope offers 2-Perf and 3-Perf capabilities.

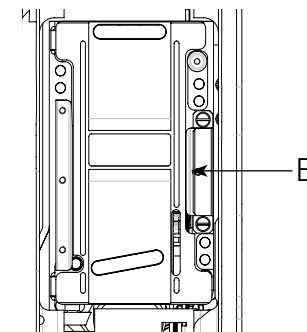
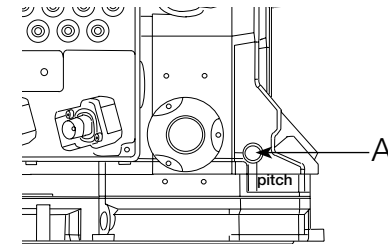

## 2.5 Camera power

Penelope requires a minimum 12.4V power source.

An Aaton 14.8V 4.2Ah Lithium-Ion onboard battery can run the camera for twenty 400' magazines, i.e. three hours of 2-Perf shooting.

When the video-assist is activated and power hungry accessories such as zoom focus and iris remote control, video transmitter and monitor are connected to the LEMO sockets, it is highly recommended to install an additional Lithium-Ion battery.

When running AatonCode, you should never leave the camera unpowered. Thanks to a built-in super-capacitor, the TCXO can handle a 10 minute power interruption, so you have plenty of time to change the batteries. Nevertheless remember that a depleted battery still has enough power to keep the TCXO alive for hours, do not remove it unless you have a fresh battery on hand.

When running the camera from a heavy battery pack on the floor, the cable is disconnected during moves and at lunch time, the super-capacitor buffering is not enough, put a battery onboard (even a depleted one) before disconnecting the power cable. After cable reconnection, confirm that time-code is still incrementing by checking the control panel.

### Installing batteries

To install a battery, loosen the blue knurled screw (**A**) approximately four or five turns. Push the battery plug into the XLR-4 socket, then tighten the knurled screw until the battery tab is held firmly.

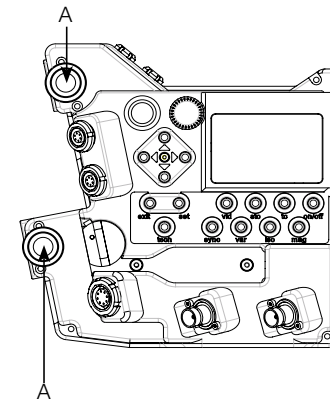

### **Charging the batteries**

The Aaton Li-Ion batteries must be charged with the Aaton Cha-Li three-hour charger. If you can't even tolerate the low noise level of its fan (around 30dBA at one meter), use a silent Aaton Chascot five-hour charger.

Both chargers can simultaneously charge two batteries.

### **Other power sources**

A variety of 14 to 16VDC sources can be used to power the camera: AC-DC power supplies, battery blocks, Lithium-Ion, and lead-acid car batteries.

Since Penelope's power sockets are universal XLR-4s, you should always carry an XLR-4 powercable in your package.

Regarding AC-DC power supplies, it is recommended that the unit be able to supply 10A peak and 60W. Before connecting any non-standard source, always make sure that the pin configuration of the unit is correct. See Chapter 5 for wiring details.



## 2.6 Motors

Three crystal controlled tri-phase motors are in use: one for the claw mechanism, one for the magazine drive, one for the shutter. Penelope is capable of speeds between 3 and 40fps with a standard Li-Ion 14.8V battery.

### Film frame-rate

Penelope provides preset crystal speeds (**SYNC**) and Operator tuned crystal speeds (**VAR**) in .001 increments, all accessible from the LCD control panel.

**NOTE:** once the frame-rate is set, the thousandths are not displayed.

Available preset speeds are : 6, 12, 18, 20, 23.98, 24, 25, 29.97, 30, 33.33, 36 and 40fps. The «sync» key allows for quick access to these frequently used speeds.

If any other speed is desired, or if the camera speed must match the frequency of a monitor to eliminate a rolling bar, the «var» key should be employed. The speed selector gives access to any speed between 3 and 40fps in .001 frame steps. A phase adjustment of the variable speed is available while pressing the «left» and «right» keys.

The camera speed can also be adjusted while the camera is running in either sync or variable mode. For more information on these speed functions, refer to the «LCD control panel and jog wheel» section of this chapter.

## Using external speed control

Penelope can be driven externally from devices such as film to video synchronisers and external speed controls. In these situations, the camera «var» selector must be set to **EXT** mode. If such a device is connected and the selector is not set to **EXT**, the camera will run at the speed indicated on the display.

Keep in mind that, with certain manufacturer's speed controls, it may be possible to ask for a speed higher than 40fps. In that case, the camera won't run at speeds higher than the 40fps factory limit. It will run at 40fps, and the fps value on the LCD control panel will be blinking.

## 2.7 Assistant's side LCD control panel and jog

Penelope utilizes a straightforward and intuitive control panel structure in conjunction with a jog to access and adjust all Operator parameters.

### The jog

Located to the immediate left of the LCD screen, the jog (**A**) is a small knob designed to speedup many user functions. It allows quick adjustment of parameters such as a precise 5-digit speed or a short end footage entry.

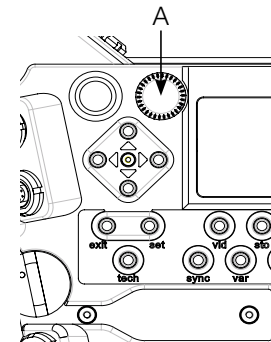

### Basics: «sync», «var», «iso», «mag»

The «set» key lets you enter the basic film camera settings, they are modified by either toggling the «up», «down», «left» or «right» key, or by rotating the jog. Press «set» to accept your choice, press «exit» to leave things unmodified.

### AatonCode initialization

As a standard feature, Penelope is equipped with the AatonCode in-camera timecode recording. Timecode is exposed onto the film by optical projection of seven micro-diodes located in the gate.

These micro-diodes flash rapidly to form the code as the film rolls through the gate between exposures.

To enter the AatonCode Menu, press the «set» key, then «tc». Choose the way you want to initialize the TC using the «up», «down», «left» or «right» key.

If AatonCode has been initialized in the camera, you can see it in the left bottom corner of the LCD display in the format: **hours : minutes : seconds**.

- The «e» flag indicates that the timecode has been jammed from an external TC source, through the LEMO-5 connector.

If no signal is present, the message **Jam Failed No LTC** is displayed.

If a signal is present, the TC is displayed.

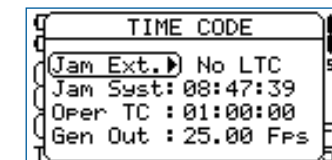
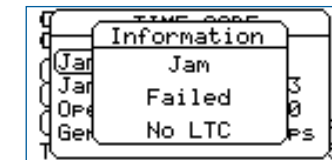
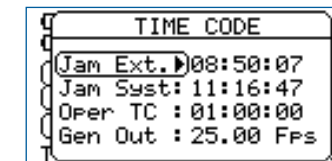
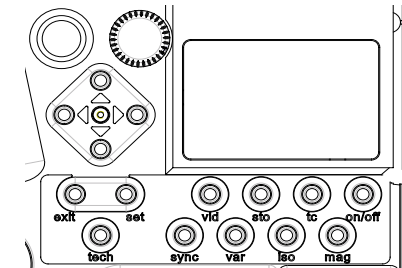

- The «a» flag indicates that the timecode has been initialized using the Aaton OriginC+ master clock through ASCII communication.
- The «s» flag indicates that the timecode has been jammed from the internal system time of the camera.
- The «o» flag indicates that the timecode has been manually entered by the operator.
- The «b» flag indicates that the timecode has been memorized during a short power down. The camera is equipped with an instantly charged super-capacitor buffer that is designed to keep time between battery changes. The super-capacitor allows 10 minutes for battery replacement before timecode is lost.

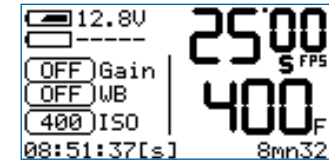

### Timecode generator

To activate the camera's timecode output, press the «set» key, then the «tc» key. With the «down» key, go to **Gen Out Menu**.

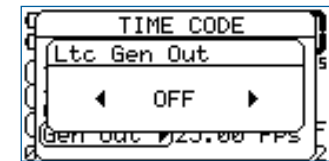

With the «left» or «right» key, select from: **OFF / 24 Fps / 25 Fps / 29.97 df / 30 Fps**. Press the «set» key to accept the change.

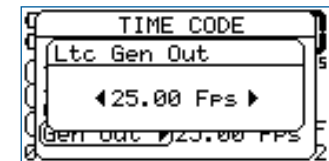

## ISO setting

When using AatonCode in Penelope, the ISO setting must be adjusted to the exposure index of the film stock. The ISO selection insures that the matrixes recorded on the edge of the film are correctly exposed. This ISO value is stored for each RFID magazine, identified by a letter from A to J. If AatonCode is not running in the camera, the ISO setting has no effect. Press the «set» key and then the «iso» key to enter the **ISO Menu**. Use the «left» or «right» key to associate a unique letter (A - J) to each magazine. Use the «up» or «down» key to adjust the **ISO** setting. Make your selection between 25 and 1000 **ISO**, by rotating the jog or by pressing the «up» or «down» key.

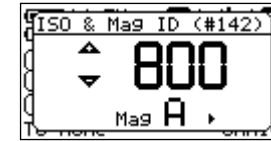

## SYNC speed

Upon being powered up, the control panel's Home page displays the camera's speed selection and whether it is in **SYNC**, **VAR** or **EXT** mode. When the camera is turned on, the actual running speed to the .01 frame is displayed. To adjust the preset speed, press the «set» key, then the «sync» key. Make your selection of stepped crystal speed between 6 and 40fps by rotating the «jog» wheel, or by pressing the «up» or «down» key. Press the «set» key to validate your selection.

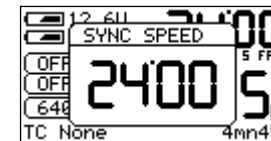

## VAR speed

To choose a specific speed, press the «set» key, then the «var» key. Make your selection of any .001 incremented crystal speed between 3.000 and 40.000fps via the «jog» wheel, or .1 with the up or down key. Press the «set» key to validate your selection.



## EXT speed

For the film camera to be driven from an external source such as external speed control or film/video synchronizer, generating 100ppfp (pulses per film pict), press the «set» key, then the «var» key. Press the «var» key once again to switch from **VAR** to **EXT SPEED**.

Press the «set» key to validate your selection.

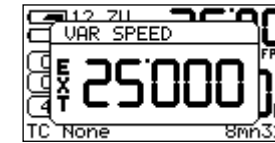

## EXT SYNC speed (with incoming 1 or 2 ppf signal)

To synchronize the camera to the scanning rate of a computer or video monitor while removing the roll bar, press the «set» key then «tech» to open the **Technical Menu**.

Select the **EXT SYNC** item with the «down» key then the «right» key to access it. Select 1 or 2ppvf (pulse per video frame) with the «up» or «down» key. Press the «set» key to validate your choice.

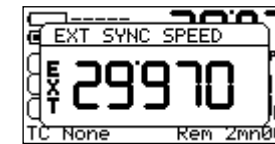

To get access to the external sync speed mode, press the «set» key, then the «var» key. Press the «var» key twice to switch from **VAR** to **EXT SPEED** and to **EXT SYNC SPEED**. If a valid incoming sync signal is detected, the appropriate speed is displayed. Run the camera and press the «up» or «down» key to remove the roll bar. This one-time phase adjustment sets the relationship of the camera shutter to the source signal. After this initial phasing this relationship remains identical every time the camera is turned on, the roll bar remains off-screen.

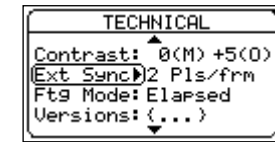

**NOTE:** If the source signal is faulty or invalid, the camera runs at 3fps, the speed icon is blinking.

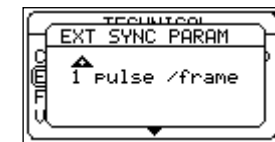

## Low battery alert

If Batt.1 or Batt.2 reaches the minimum preset level, e.g. Batt Alert = **14.4V**, an alert appears on both LCD screens and a red LED blinks in the camera viewfinder.

The camera continues to run properly and **LOW BATT** is displayed in front of the battery icon.

If both batteries are low, the alert is displayed on both the Assistant's and Operator's screens.

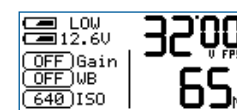

Low batt 1

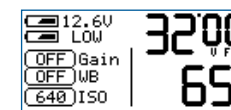

Low batt 2

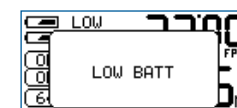

Low power

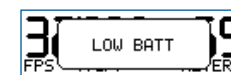

Low power (Operator's)

## Technical menu

The **Technical Menu** provides access to:

**LEMO mode, Video out, Syst Time, Batt Alert, Contrast, Ext Sync, Ftg Mode, Version, Lens Data, Video Capture, Load Soft, SlowStart, NoFilm Mode.**

To access the **Technical Menu** press the «set» key then «tech».

Select one of the sub-menus and press the «right» key.

Select the mode by rotating the «jog» wheel, or pressing the «up» or «down» key.

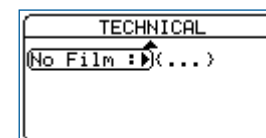
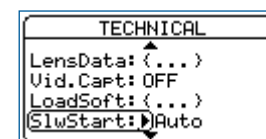
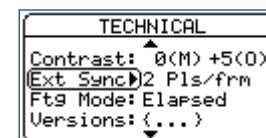
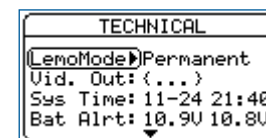

## LEMO start mode

Two Run/Stop modes are available for accessories using Penelope's LEMO connectors.

- **IMPULSION** for accessories using a pulse signal.
- **PERMANENT** for the Aaton wooden handgrip, and ON/OFF switches and cable made for the 35-III, Xtera, XTR-prod cameras.

Select the **LEMO Mode** item and press the «right» key. Select the mode by rotating the «jog» wheel, or by pressing the «up» or «down» key. Press «set» to validate your selection.



## Video Out menu

Penelope offers four independently programmable video outputs: two BNCs and two FISHER-4s). Each can be turned OFF to save power (**OFF**) or turned ON with picture only (**DataOFF**) or with picture and burned-in characters (**DataON**).

Select the **Video Out** item and press the «right» key. Select the desired video output by using the «up» or «down» key, press the «left» or «right» key to switch between: **OFF**, **DataOFF**, **DataON**. Press the «set» key to validate your selection.

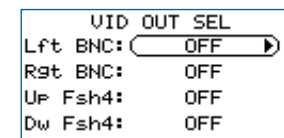
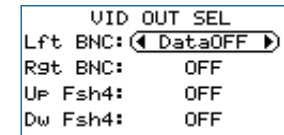
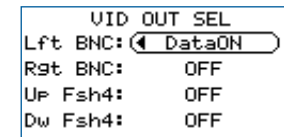



## System Time

To manually set the internal camera timecode, press the «set» key then the «tech» key to open the **technical** menu. Select the **Sys Time** item and press the «right» key to access.

The display will show the camera date and time.

Use the «left» or «right» key to select the following parameters: year, month, day, hour, minute, seconds.

And use the «up» or «down» key to modify each one of them.

Once you have set all of the date and time fields, press the «set» key to validate your selection.

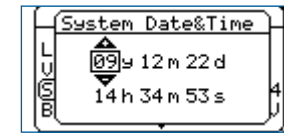

## Adjusting the low-battery alert level

Penelope displays alerts when the battery voltage falls below a preset level. The thresholds set for Batt.1 and Batt.2 do not override the cameras default minimum levels.

Select the **Bat Alert** item and press the «right» key to access it. Select a value between 14V and 15V for each battery by rotating the «jog» wheel, or pressing the «up» or «down» key. Press «set» to validate your selection.

The alert level for Aaton Lithium-Ion onboard batteries must be set at 14.4 minimum, *this will leave enough power for you to shoot a complete 400 foot magazine.*

**NOTE:** firmware v1.28 and up is required to adjust the warning level to 14.4V.

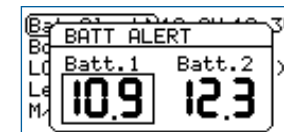

## Display contrast adjustment

To adjust the LCD contrast, select the **Contrast** item and press the «right» key to access it. Select **Main LCD Contrast** by rotating the «jog» wheel, or by pressing the «up» or «down» key. Press the «right» key to access the Operator's LCD and follow the same procedure. Press the «set» key to validate your selection.

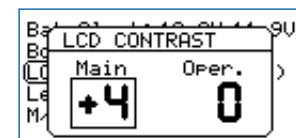
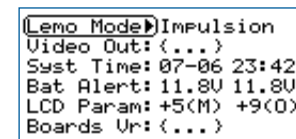

## External Sync

To remove the roll bar while filming a video monitor, the film camera must be synced to its vertical scanning rate, depending on the sensor used to measure this rate you must set the **Ext Sync** item to either 1 or 2 ppvf, see p.37.



## Footage Mode

You can display either the remaining or elapsed footage in the magazine. Use the «down» key to select the **Ftg Mode** item and press the «right» key to access it. Choose between **Remaining** or **Elapsed** by pressing the «left» or «right» key. Press «set» to validate your selection, then the «exit» key.

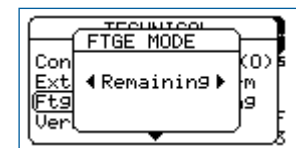

## Software Version

For troubleshooting, access to internal camera technical information might be useful before contacting your service center.

Select the **Version** item and press the «right» key to display it (read only).

## Lens Data

To display on both the camera screen and the video-assist monitor the data coming from a Cooke/i lens installed on the camera port, select the **Lens Data** item and press the «right» key to access it. With the «right» key, select **Rx ON** or **Rx OFF**. Press «set» to validate your selection and exit the menu.

## Video-assist proxies

Still images (jpeg format) can be captured from the video-assist camera and copied onto a FAT32 formatted USB key.

When the USB key is recognized, a disk icon appears on the screen.

See p.61.

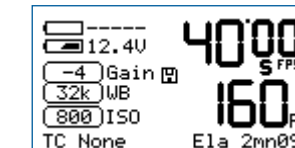
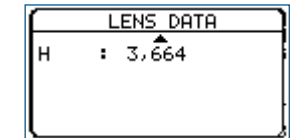
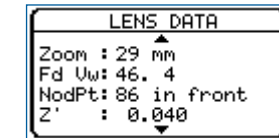
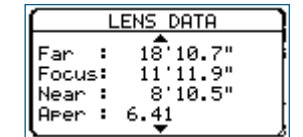
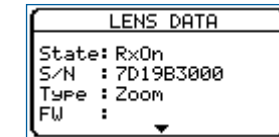
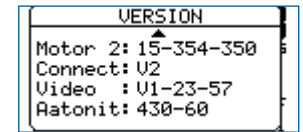
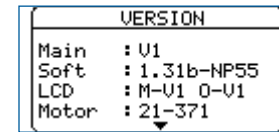

## Firmware Install

To update the firmware, copy the new **Penelope\_Vx.xx.flb** file onto a USB key (FAT32 formatted).

With the camera powered-down, plug the key into the USB socket and power-up the camera electronics with the “on/off” key. When the USB key is recognized, a disk icon appears on the main screen.

Select the **LoadSoft** item and press the «right» key to access it. Select the version by pressing the «left» or «right» key, and wait for 2 seconds to see the complete version names scrolling. Press «set» to validate.

The messages **Loading**, **Prog Start**, **Erasing**, **Programming**, and **Success** will successively appear, and then the final one: **Please Shutdown**.

Power-down the camera by pressing the «on/off» key for four seconds, then power-up again, the new software is installed.

**NOTE1:** it is **STRONGLY RECOMMENDED** to install freshly charged batteries before starting the install process. If the camera loses power before it has completed loading the new software, the unit will have to be returned for repair.

**NOTE2:** do **NOT** power down the camera until you are told to.

**NOTE3:** following a firmware installation, at camera start up a message might appear indicating an automatic update of both the motor and logic boards.

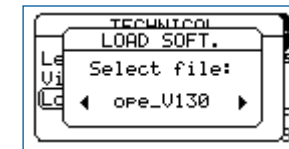
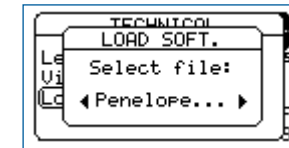
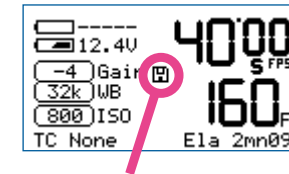

## Slow Start

For low temperatures operation and in order to reduce the motor power consumption at start up, a «Slow Start» can be chosen.

Three choices are available :

- Normal mode : no temperature detection.
- Auto mode : a temperature sensor will switch the camera to «Slow start» mode at temperature below 10°C.
- Slow mode : forced slow start mode

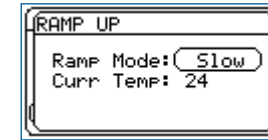
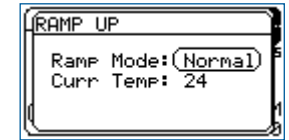
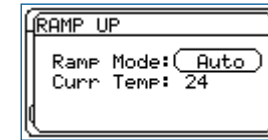

## No Film Mode

To allow a start of the camera without film, activate the NoFilm menu.

note : in this mode, the camera can't start with film !

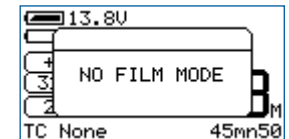
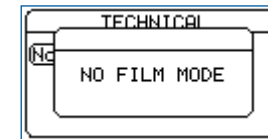

## 2.8 Operator's side settings

Three keys are located on the Operator's side, close to the vertical LCD screen:: «lower» (1), «middle» (2), «upper» (3).

- Press the «middle» or «upper» key to adjust the **AatoNite** frame brightness, see Chapter 1.
- Press the «lower» and «middle» keys to select the **SPEED** item, press the «lower» key to make it blink, you can now modify the **SYNC** and **VAR** film running speed. Press the «middle» or «upper» key to modify the speed value. Press the «lower» key to validate.
- Press the «lower» key and «upper» keys to select the **MAG** item, press the «lower» key to make it blink, you can now set the magazine footage. Press the «middle» or «upper» key to modify the footage value. Press the «lower» key to validate.

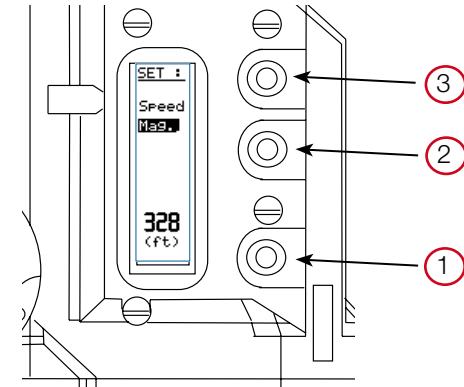

## 2.9 Cold weather tips

From Rune Ericson, based on his experience in filming in Greenland.

- When filming outdoors in extreme cold, the camera and lenses should not be taken indoors at all, so as to avoid condensation on the electronic parts and glass surfaces.  
In any case, the camera (and lenses) should not be stored above 0°C. If the camera must be taken inside, then it should be put in a hermetically sealed container. It should be allowed to thaw for a few hours before being removed from the sealed container.
- The raw stock should also be kept below zero. For the same reason as above, the magazine should be loaded in the cold.
- The Aaton Li-Ion onboard batteries should be used in preference to battery belts, several small batteries can be warmed up much more easily than one large heavy one. Each member of the shooting crew can keep one in his or her breast pocket.
- At 30°C below zero, Rune advises documentary filmmakers to sleep with the batteries in their sleeping bag...

3

Magazine





### 3.1 Concept

The Penelope magazine is designed to be installed or removed quickly, and to be loaded easily, it handles up to 400ft (122m) loads of 35mm film stock. The magazine sprockets are driven through a magnetic clutch by a motor located in the camera body itself. This system reduces noise and power consumption, and prevents mechanical abuse in case of misloading. The feed roll footage can be checked through a mechanical footage counter located on the magazine door. The remaining or elapsed footage also appears on the camera control panels, see Chapter 1.

### 3.2 Pressure plate system

#### Claw rear pressure plate

This plate (A) is located at the front of the magazine. When the loaded magazine is installed on the camera body, its main function is to hold the film as the claw engages the film perforations. Proper positioning of this element is essential to steadiness and quietness of operation.

#### Picture rear pressure plate

The striped pressure plate (B), positioned at the camera's picture taking gate level, holds the film in the right back focus position.

**NOTE:** to keep the film in place laterally the pressure/guidance guides are on the gate plate.

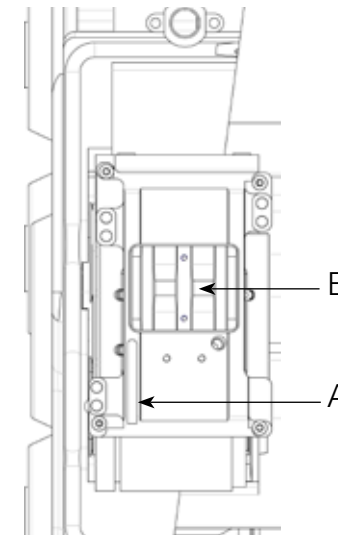

### 3.3 Loading the film (in 17 steps)

The magazine design allows for a quick and easy loading procedure and reduces the number of operations to be performed in the changing bag, to the absolute minimum.

#### In the light

- 1 Place the magazine in front of you, throat on the left.
- 2 Turn the mechanical footage counter (A) clockwise until it locks in place.
- 3 Unfasten the three blue locking levers (B), turning them counterclockwise.
- 4 Open the door.
- 5 Check the magazine for dust and debris.
- 6 Put the magazine in a dark room or changing bag.

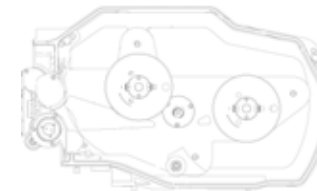
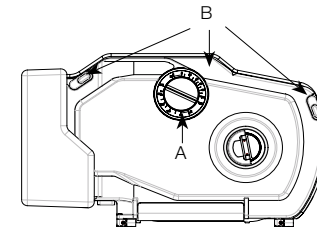

**In the dark**

**7** Remove the film from its can and bag. Place the film on the feed spindle with its winds clockwise.

**DON'T FORGET** to press the center of the core lock mechanism to lock the core in place **(A)**.



**8** Push the film head into the center slot **(B)**, until it engages the inner sprocket wheel.

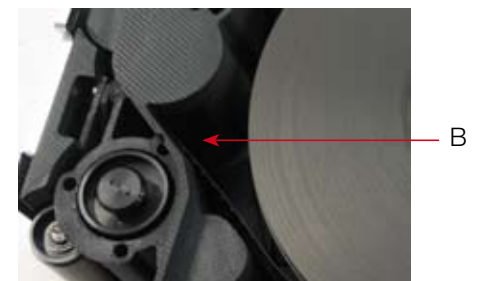

**Still in the dark**

**9** Guide the film with your left index finger and turn the take-up core holder clockwise, making sure the film perforations engage the sprocket teeth.



**10** When the film comes out of the sprocket assembly, gently pull on it.



**11** Pull the film out about 20 cm (8 inches) and insert it in the bottom slot until it meets the lower sprocket teeth.



### Still in the dark

**12** Guide the film with your left thumb (**A**) and index finger and turn the take-up core holder clockwise until the film exits on the other side of the sprocket assembly (**B**). Continue to turn the take-up core holder until the film reaches the bottom roller (**C**).



**13** Place a core on the take-up spindle, press the center of the core holder to lock the core in place. Fit the film end into the plastic take-up core and wind on a few turns clockwise with the emulsion in.

**14** Close the door door and make sure that it is closed securely. The remaining steps are performed in the light.



## In the light again

**15** Engage the take-up clutch knob by pulling its lever up.

**16** Push the loop adjusting sprocket release button and hold it pressed. Turn the take-up clutch knob clockwise (while gently pressing on it) to shorten the loop size until the loop adjustment tool is held between the film and the pressure plate.

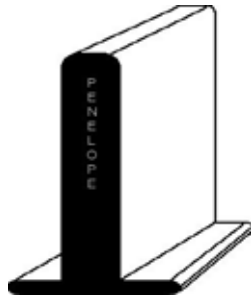

**NOTE:** the loop adjustment tool makes a loop corresponding to approximately 37 visible perforations.

**17** Once the loop has been set, check that the lower sprocket release button has returned to its UP position.

## Installing the magazine

To install the magazine, stay at the rear of the camera body, Operator's side. Place your right hand underneath the magazine while your left hand is firmly holding it at the midway point of its rear. Rest the nose of the magazine on the camera base, hold the camera body with your left hand while pushing the mag in the bottom dovetail and into the aperture area with your right hand. Make sure that the top of the nose of the mag is parallel to the camera as you guide the mag in place. Push firmly and evenly until you feel and hear that the mag snaps against the aperture area.

Don't forget to lock the magazine by pushing the magazine upper locking lever.



## Removing the magazine

To remove the magazine, stay at the rear of the camera body, Operator's side. Unlock the magazine upper lock lever and push the magazine release lever (A) toward the front of the camera.

Pull the mag off the camera body.

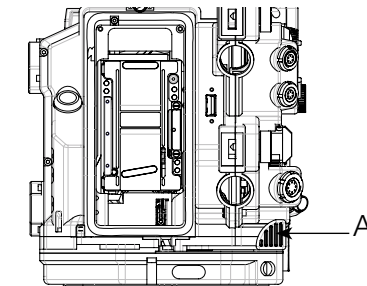

4

Video-assist





To power up the **VHR video-assist**, press the «set» key then the «on/off» key once the film camera electronics have been powered up.

To display the **VHR Menu** (Main menu) on the video monitor screen, press the «set» key then the «vid» key. A message is displayed on the Assistant's control screen (see pict. top right).

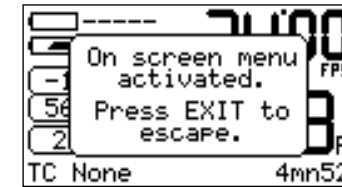

The **VHR Menu** contains five items:

- **Image look** (Video menu) (4.1)
- **Frame & mask** (Frame menu) (4.2)
- **Proxy capture** (Vid. capture) (4.3)
- **Metadata insert** (Technical menu) (4.4)
- **Logo insert** (not yet activated) (4.5)

The «up» and «down» keys select an item.

The «set» key opens an item.

The «up», «down», «right» and «left» keys modify the parameters.

The «exit» key enters the change.



#### 4.1 Image look (Video menu)

Opens access to:

- **Gain**
- **Color temp.**
- **Color saturation**
- **Color Bars**
- **Color/B&W out**

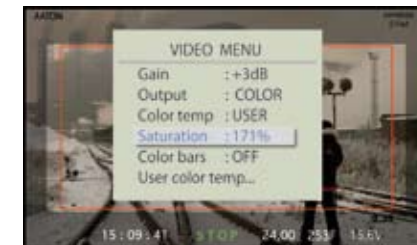

- **Gain**

Use the «up» or «down» key to modify its value.  
It can also be modified by using a direct access shortcut.

- **Color temp.**

- **Tungsten** or **Daylight**. Selecting one or the other makes **[3200K]** or **[5600K]** appear in the CT field of the Assitant's control screen.

- **Manual white** This is directly activated by pressing the «set» then the «right» key. To perform a manual white balance, put a piece of white paper in front of the taking lens. If there's too much light (or not enough), the message **Too bright** or **Too dark** is displayed on the Assitant's control screen. White balance done, **OK** is displayed. **[M-WB]** appears in the CT field.

- **Manual RGB** (USER) currently opens access to the 'User color temp' line. Press the «set» key to display three RGB bargraphs, press the «up» or «down» key to select one of them and press the «left» or «right» key to modify the dB value. This lets you cope with 1800K to 7000K lighting conditions. Press the «exit» key to validate. **[M-RGB]** appears in the CT field of the Assitant's control screen.

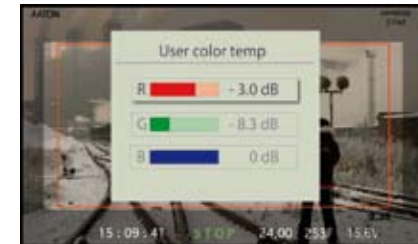

- **Color saturation**

A highly saturated image displays vivid colors, less saturated it appears grayish. Saturation goes up to 200% (factory: 160%).

- **Color bars**

These bars are useful to calibrate an NTSC monitor by tuning the color phase setting while displaying the monitor's blue only channel.

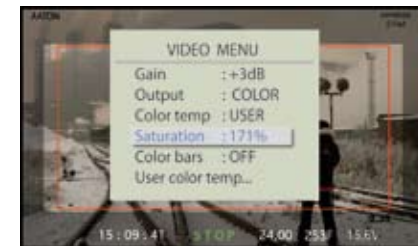

- **Color/B&W out** (Output).

## 4.2 Frame & mask

Opens access to

- **Activation**
- **Templates**
- **Top left corner**
- **Bottom right corner**
- **Frame color**
- **Frame move**
- **Mask appearance**

- **Activation**

Select **ON** to open access to four 'frame & mask' templates and to activate their insertion.

- **Templates**

Four different templates store the rectangular frame and associated mask to be inserted into the video-assist image.

Press the «right» key to select one of the four templates.

- **Top left corner**

The rectangular frame can be set in size and position to perfectly match the camera viewing screen markings. Press the «set» key to enter and modify the corner position using the «up», «down», «left» or «right» key,

- **Bottom right corner**

Proceed in the same way as above.



- **Frame color**

Change the color of the rectangular frame. Play with the RGB values then press «exit».

- **Frame move**

Lets you move the whole frame in the picture without affecting its size or ratio.

**NOTE:** a frame can be set to match the viewing screen's markings but it can also be used to outline an object in the picture during a product shot.

- **Mask appearance**

A transparent mask can be added outside the rectangular frame. You can change its color and its transparency percentage.

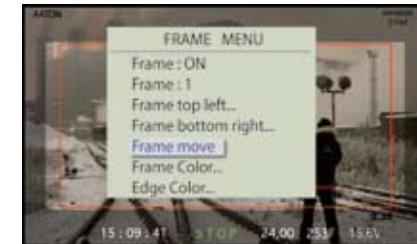

### 4.3 Proxies capture

Called proxies, small still images (jpeg format) can be captured from the video-assist and copied into a folder on a FAT32 formatted USB key (one folder is automatically created for each camera take).

When the USB key is recognized, a disc icon appears on the main screen.

Select the **Proxy Capture** (Vid. Capture) item and press the «right» key to access it. Select the mode by pressing the «left» or «right» key: **OFF**, **Evry 1s** (every second), **Evry Ns** (every N seconds), **AUTO** (three seconds after RUN, middle of the take, three seconds before STOP).

Press «set» to validate the selection.



#### 4.4 Metadata insert

Metadata insertion can be moved anywhere in the picture with the «up», «down», «left» and «right» keys.

- **AatonCode**
- **Battery voltage**
- **VITC line & parity**
- **Lens Data**
- **Film status**
- **Software/hardware**

- **AatonCode**

**Time, Date, Camera ID.** The positioning of these three 'words' currently is directly accessible from the **VHR Menu** (Main Menu).

- **Battery voltage**

The higher of the two battery voltage is displayed. When the low battery alert level has been reached, the battery voltage characters start blinking.

- **VITC line & parity** (not yet functional)

PAL VITC lines can be inserted from **10** to **23** (line **19** is common practice). For NTSC, **13** to **19**.

Ask your editing staff the line # they prefer to work with.

**ODD** or **EVEN** parity interleave: ODD is common practice.

- **Lens Data**

As transmitted from the Cooke i/lens system.



TECHNICAL MENU	
Time code	: ON
Batt voltage	: OFF
VITC position	: 23
Parity	: ODD
Software	: V1.25

TECHNICAL MENU	
Time code	: ON
Batt voltage	: ON
VITC position	: 23
Parity	: ODD
Software	: V1.25

- **Film status**

Film speed (in fps), and remaining or elapsed magazine footage (in foot or meter).

The shooting status appears as **RUN** in green characters, or as **STOP** in red. Its positioning is factory set and can't be moved away from the center bottom of the video-assist monitor.

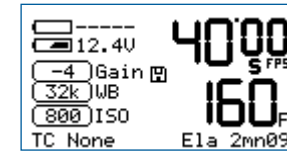

- **Software/hardware**

The video-assist software version and the hardware model is displayed on the Assitant's control screen as well as on the video monitor screen.

## 4.5 Logos

Logos can be inserted anywhere in the video picture.

*This function is not yet functional.*

- To upload a **Logo**, connect your computer through the 'LEMO-5 Serial Port' cable.
- Once the **Logo** has been imported, you can modify its **transparency** and its **position**.

5

Technical drawings

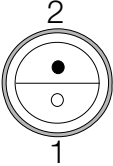
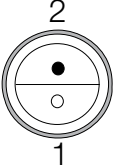
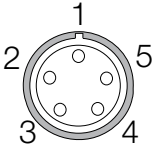
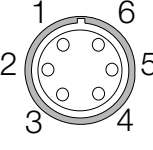

Type	Functions	Diagram	Pin description (from user's side)
LEMO-2	On/Off		1 Ground 2 Start
Fischer-2	Heating cable		1 Ground 2 + Batt.
LEMO-5	Timecode		1 Ground 2 SMPaTE In 3 ASCII In/out 4 NC 5 NC
LEMO-6	Power		1 Ground 2 NC 3 NC 4 + Batt. 5 NC 6 Start

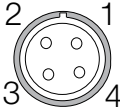
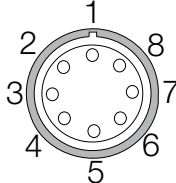
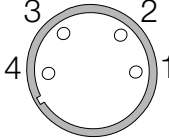

Type	Functions	Diagram	Pin descriptions (from user's side)
Fischer-4	Video output		<ul style="list-style-type: none"> <li>1 Ground</li> <li>2 Video ground</li> <li>3 Video output</li> <li>4 + Batt.</li> </ul>
LEMO-8	Speed Controllers		<ul style="list-style-type: none"> <li>1 Ground</li> <li>2 One pulse per frame</li> <li>3 ASCII In/Out</li> <li>4 + Batt.</li> <li>5 Tach. out</li> <li>6 Start</li> <li>7 Tach. in</li> <li>8 Ground</li> </ul>
XLR-4	Power In		<ul style="list-style-type: none"> <li>1 Ground</li> <li>2 Start (only wired on cameras identified by an engraved white dot close to the bottom XLR)</li> <li>3 + Batt.</li> <li>4 + Batt.</li> </ul>

## 2-Perf S35 centered

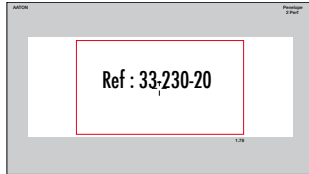

Full gate, 1.78.

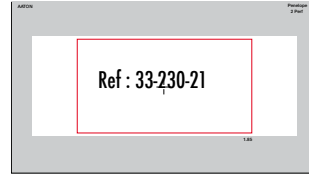

Full gate, 1.85.



Full gate, 2.35.

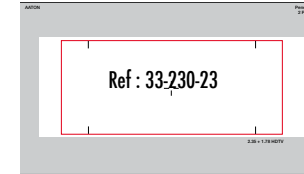

Full gate, 2.35 (1.78 markers).

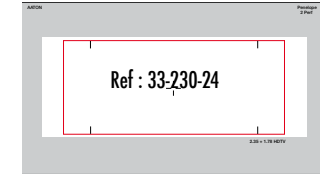

Full gate, 2.35 (1.78 markers), darker surround.

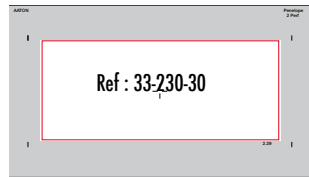

2.39 (with full gate ext. markers)

- The Aatonite frame is in red
- 1.78 = 16/9 ratio.

## 3-Perf ANSI S35 centered

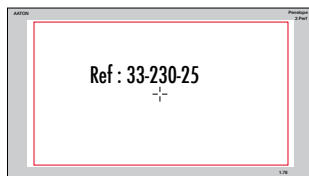

Full gate, 1.78.

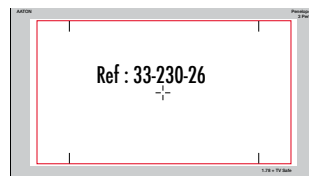

Full gate, 1.78 (1.33 markers).



Full gate, 2.35.



Full gate, 2.35.

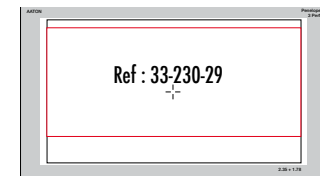

Full gate, 2.35 (up offset), 1.78.