

Instruction Manual



ARRIFLEX
16SR II

Guide to the ARRIFLEX 16 SR II-E

The 16 SA II-E is the basic model of the 16 SR II and as such has the same basic filming functions.

The instruction manual can be used for both models; certain sections must be included or excluded depending on the extent to which the 16 SR II-E has been upgraded.

However, care must be taken that when the 16SR II-E has been fully upgraded, only zoom lenses with diaphragm rods can fulfill their function completely.

The electrical, optical and mechanical accessories can be used unconditionally as well as the 120 m coaxial quick-change magazine.

Contents

Mounting lenses	5
Working with the taking lens	7
Spring loaded diaphragm control	7
Automatic mirror shutter stop	7
Changing the 120 m /400 ft coaxial magazine	8
Loading the magazine	10
Film aperture cover	16
Magazine loop protector	16
Removing the exposed film from the magazine	17
Counter for exposed film	19
Film supply indicator for raw stock	20
The functions of the camera release on the housing	21
The drive motor and its electrical control system, pilot tone and start marking	23
The standard handgrip	24
The universal handgrip	25
The auxiliary handgrip	26
The rotating & pivoting viewfinder	27
The viewfinder extension	29
Operating the TTL -Si exposure meter	30
Fully automatic exposure control	31
Changing the fibre optic viewing screen	33
Light-weight support	34
The bridge and support plate	35
Matte boxes	36
The camera power supply	39
The 16SR time coding	41
Camera speed switch 24/25 fps or 50/60 Hz	43
Pilot tone output	43
Fuses	44
Full frame start marking lamp	45
Electrical accessories	46
The ARRIFLEX Image Stabilizer	48
Adaptation of a video system	49
EFC 16 SR digital counter	52
Film plane indicator	53
The asynchronous diode	53
The time counter	53
Service	54
Breakdown help when the automatic diaphragm and shutter drive are defective	55
Technical Data	56
ARRIFLEX 16SR-HSII	58

Illustration guide

- 1 Focusing grip
- 2 Zoom lever
- 3 Screw thread for zoom lever
- 4 Driver rings for diaphragm and focusing
- 5 Rotating and pivoting viewfinder
- 6 Collar nut for fitting the viewfinder to the camera, (this can only be carried out in an authorized ARRI Service Center)
- 7 Collar nut for fitting-the eyepiece
- 8 Eyelet for carrying strap
- 9 Lock ring for diopter adjustment
- 10 Diopter adjustment
- 11 Eyecup
- 12 Film counter, exposed film
- 13 Wind-up magazine cover
- 14 Lens index mark, white (focal length! focus)
- 15 Retention pin for light-weight support
- 16 Protecting collar
- 17 Flexicable with spring-loaded holder for connector plate
- 18 Universal hand grip cable with 4 pole plug and safety stirrup '.
- 19 Camera shoe for light-weight support and flexicable connector plate
- 20 Lens index mark, white (diaphragm)
- 21 Lens release button (left)
- 22 Rosette for fastening an additional left side handgrip
- 23 Setting for DIN/ASA
- 24 Memory button (only cameras with built-in automatic exposure control)
- 25 Retaining lever
- 26 Camera release "start" position
- 27 Camera release "measuring" position
- 28 Camera release button
- 29 Camera release "0' , position
- 30 Camera release "test" position
- 31 Hinged knob for turning mirror shutter by hand
- 32 Hinged knob for locking magazine
- 33 Safety knob for magazine lock

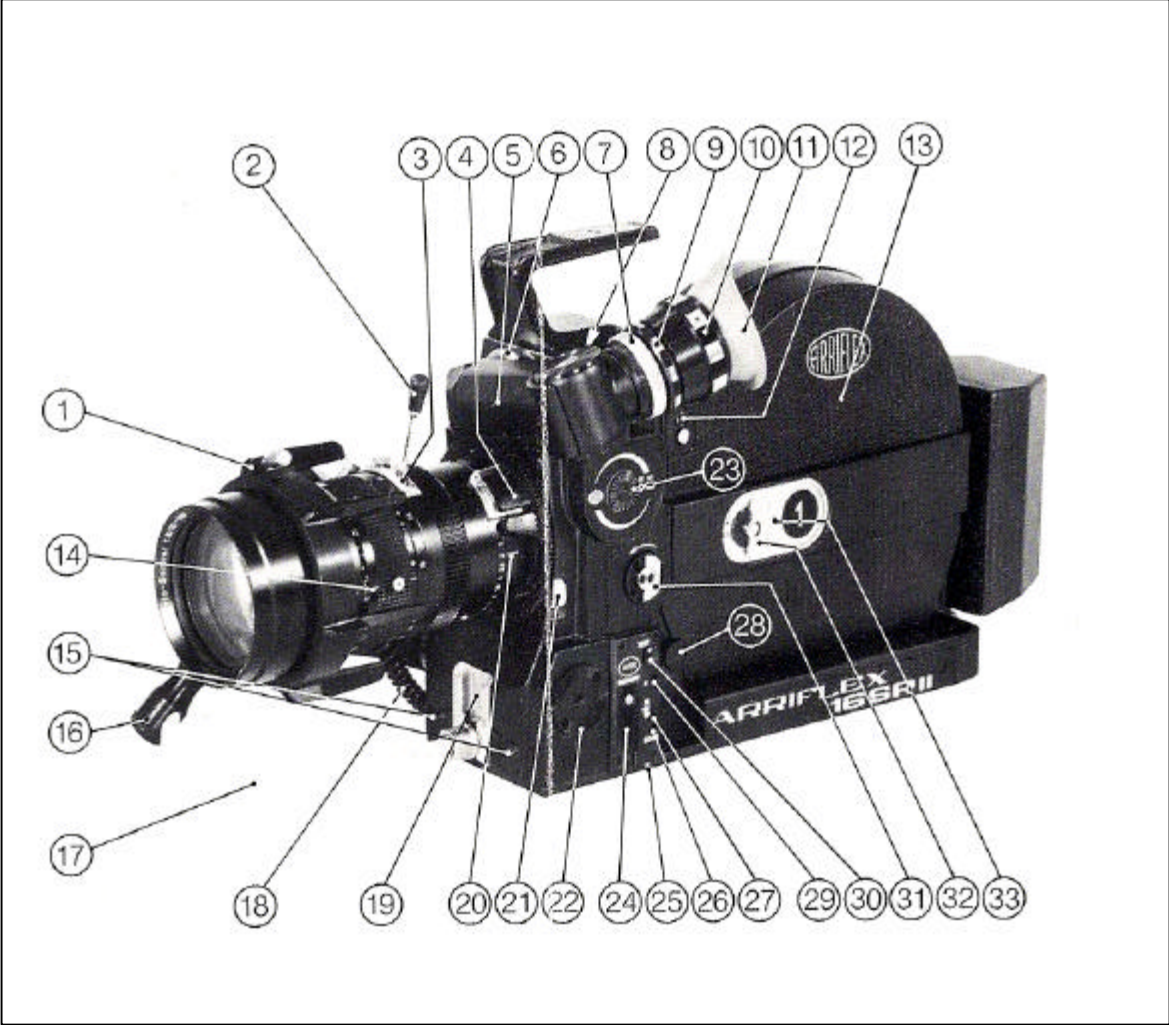

- 34 Film supply indicator, raw stock
- 35 Film supply side (magazine cover)
- 36 Release lever (magazine)
- 37 Magazine safety lock
- 38 Magazine snap catch
- 39 Carrying handle
- 40 3/8" thread for electrical accessories
- 41 Zoom ring
- 42 Magazine cover hinges
- 43 Running control light
- 44 Connector for pilot tone
- 45 Connector for electrical accessories
- 46 Thread for mounting adapter
- 47 Battery connection
- 48 Cover for electronics compartment
- 49 Eyelet for carrying strap
- 50 Film plane indicator cover plate over full frame start marking lamp
- 51 4-pole plugs for hand grip with electrical camera release (see pos. 18) or with time counter
- 52 4-pole sockets
- 53 Rosette for fitting handgrip
- 54 Folding grip for fastening handgrip
- 55 Lens release button (right)
- 56 Additional lens index (red)
- 57 Press button for cable release (in flexicable for operating spring loaded diaphragm control and preparing exposure control -measuring position - simultaneously for unlocking release button 59)
- 58 Universal handgrip
- 59 Press button for camera release
- 60 Knurled screw for zoom lever

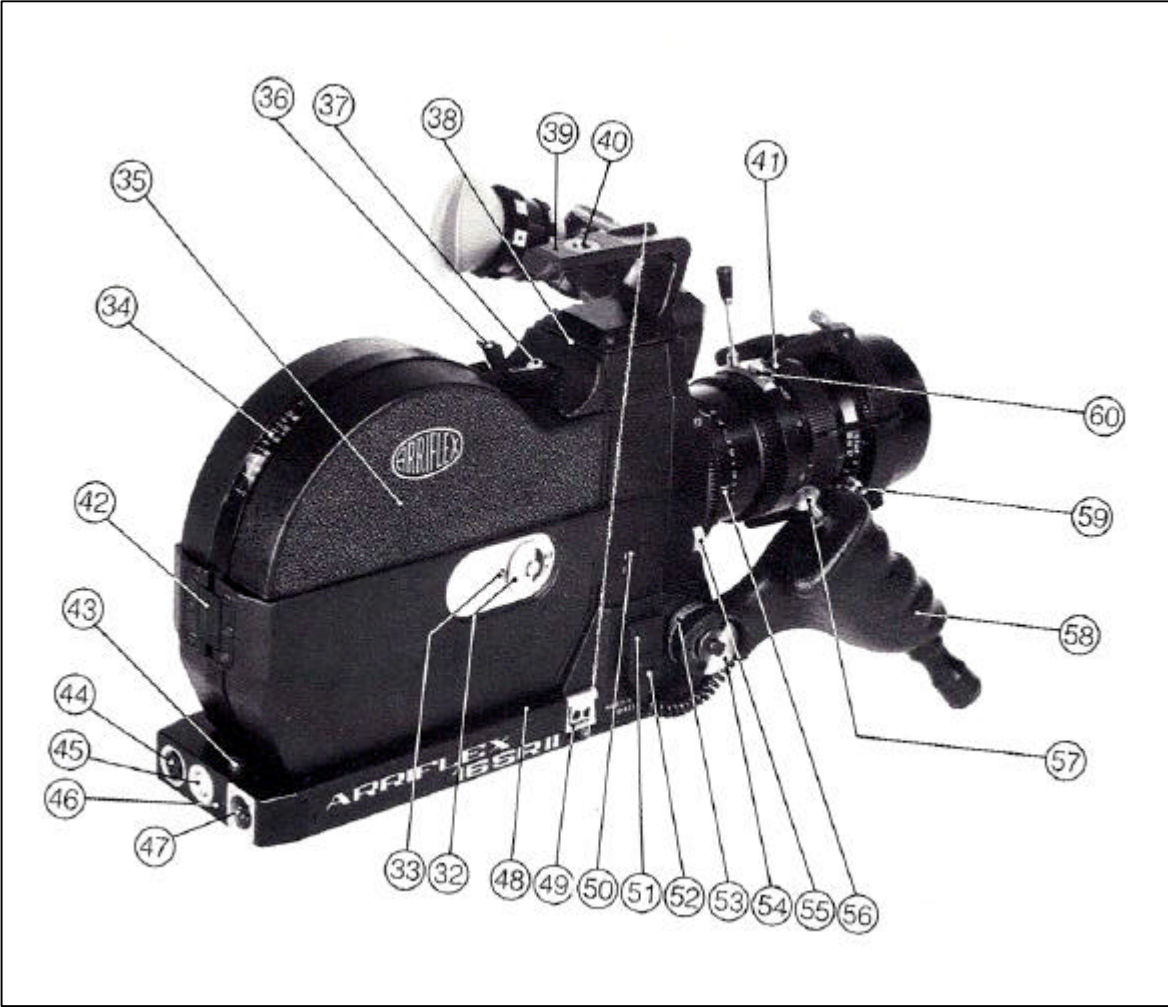

Mounting lenses

We supply zoom lenses with automatic diaphragm for use with the ARRIFLEX 16 SR II; when the taking camera is fitted with the automatic feature, these lenses can be used without any restrictions for fully automatic exposure control.

Care must be taken that all lenses, with the white index marking facing towards the exposure meter side, facing towards the exposure meter side, are gently inserted to prevent damage to the lens leader groove and the catch in the mount, which fits into this groove.

All (unblimped) zoom and fixed focal length lenses with steel bayonet or standard mount, suitable for use with the ARRIFLEX 16 BL, can also be used with the ARRIFLEX 16 SR II without any restrictions whatsoever.

To remove lenses with steel bayonet mount: press release button (55), turn the lens anti-clockwise and pullout of the lens mounting flange.

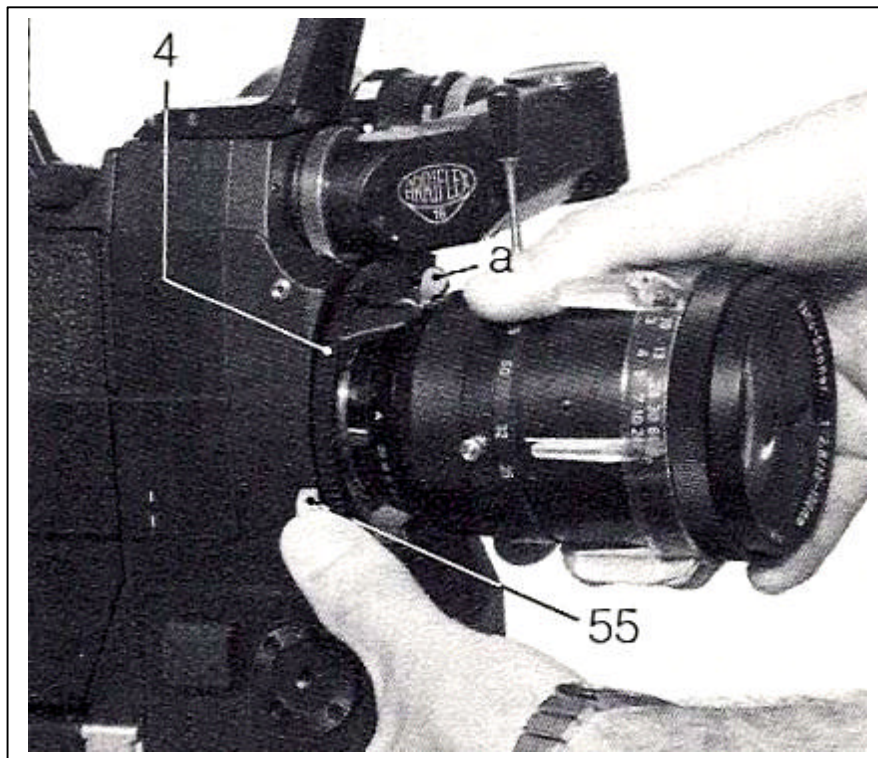

To mount lenses with steel bayonet mount: the diaphragm lever (a) is inserted into the slot of the catch ring (4), the lens (white index mark positioned as stated above) is carefully pushed into the lens mounting flange and turned clockwise until it locks.

To remove lenses with standard mount: press release buttons (21, 55) together and pull the lens out of the mounting flange without turning it.

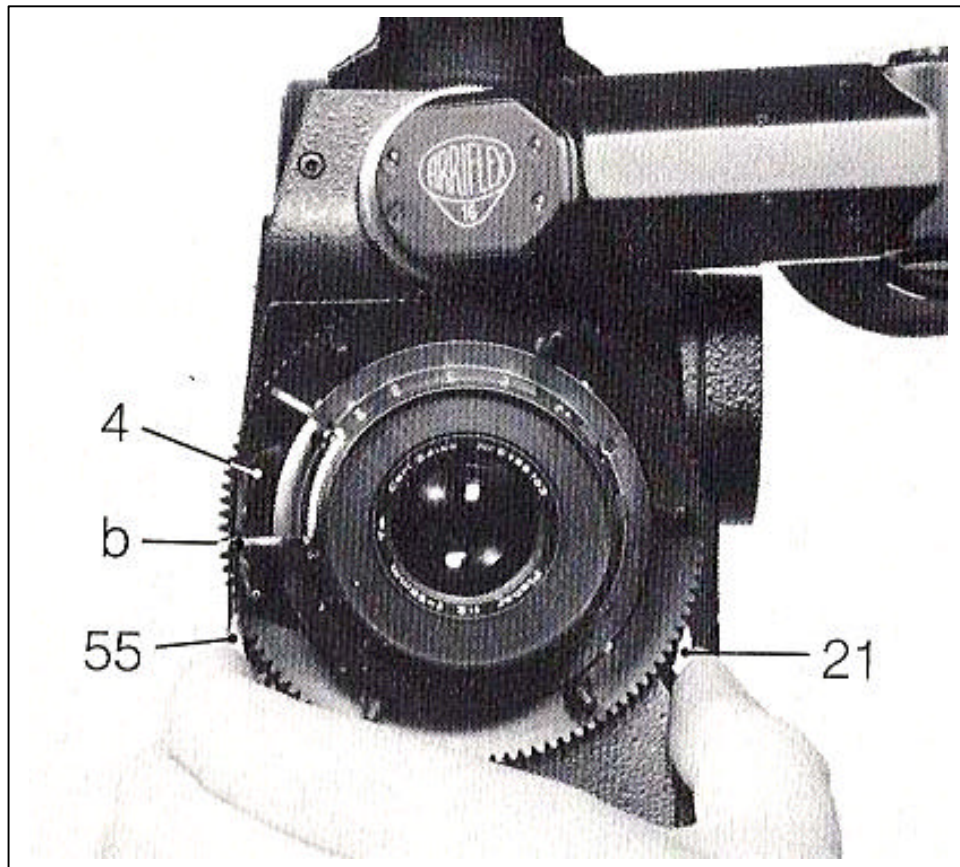

To mount lenses with standard mount: the diaphragm lever(b) is inserted into the slot of the catch ring (4). Both buttons (21, 55) are simultaneously pressed and held together and the lens (index mark positioned towards the exposure meter) is carefully pushed into the lens mounting flange. The catch in the lens mount then engages in the guide groove of the lens barrel. Release the buttons and check that the lens is firmly seated. -

Working with the taking lens

Lenses with engraved index markings on both sides and with double scales can be operated and read easily from the left and the right hand side.

The zoom lever (2) is screwed into one of the sockets, turned in the direction desired and fastened by tightening the knurled screw (60).

Spring loaded diaphragm control

The 16 SR spring loaded diaphragm mechanism works only when used with 16 SR special zoom lenses with spring diaphragm turned to "Zu/Off" position. The longer, rear rod protruding from the lens (when in use, in the upper position)~operates the iris diaphragm, the shorter rod is used to select the fully automatic exposure control. Lenses with axial or radial spring loaded diaphragm control can be used.

Automatic mirror shutter stop

Each time the camera is switched off the quartz controlled motor stops the mirror shutter in such a position that the finder is open for viewing. The opening of the shutter is 180°. The mirror shutter can also be rotated by hand by turning the hinged knob (31).

Changing the 120 m / 400 ft coaxial magazine

This process takes only seconds. Pull back the safety lever (37) to the position "Offen/Open", depress the release catch (36) at the same time

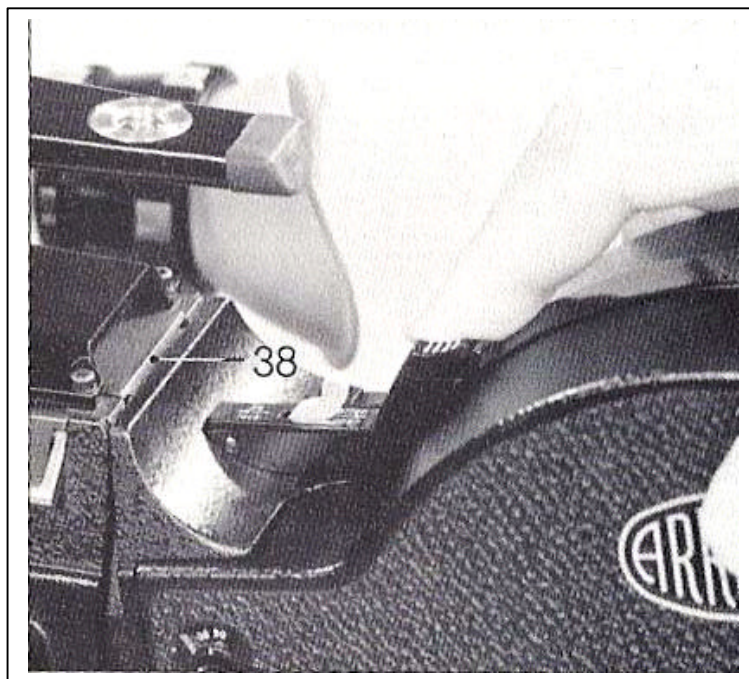
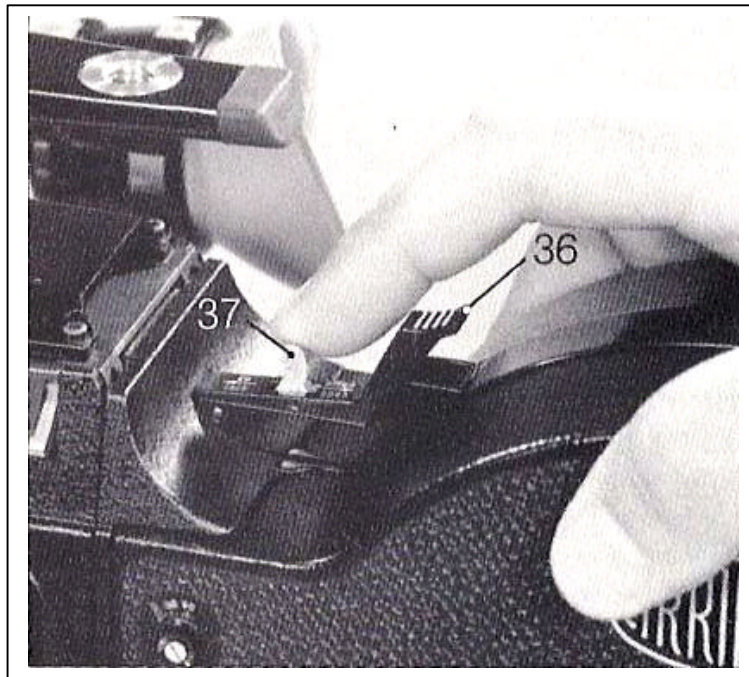

raising the magazine and removing it from the camera's snap catch (38).

To replace the magazine, engage the hinge pin (a) in the snap catch (38) and push the magazine downwards; a click is heard when the magazine locks in position.

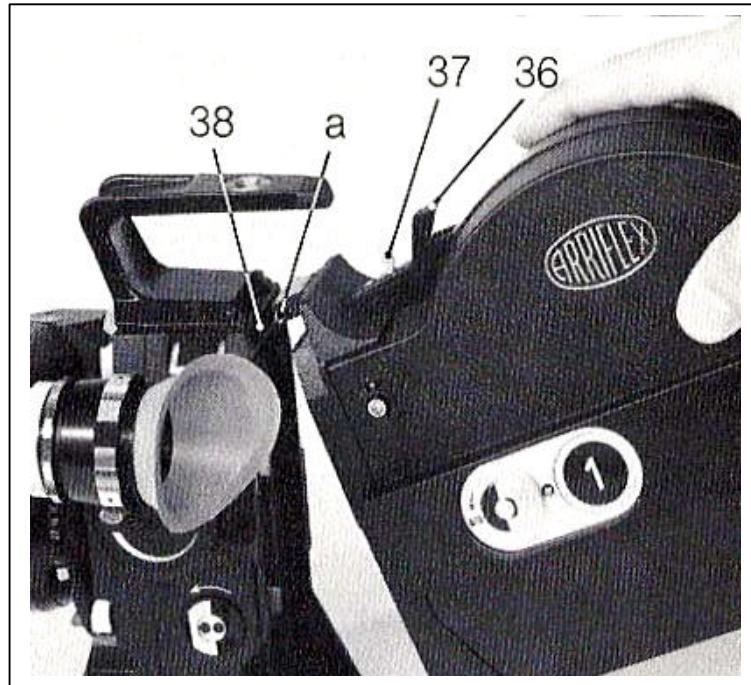

Finally, the magazine release catch (36) is locked by pushing back the lever (37) to "Lock"; the camera is then run a few turns slowly by pressing the test button (30) until the film transport claw engages with a perforation hole.

Loading the magazine

The film must be threaded with the emulsion inwards. With single perforated film care must be taken that only "winding B" film is used.

To load the film, the magazine lid on the film supply side (35) must be unlocked and swung open and the pressure roller (a) must be swung back until it engages. The magazine must be loaded in a dark room or in a film changing bag.

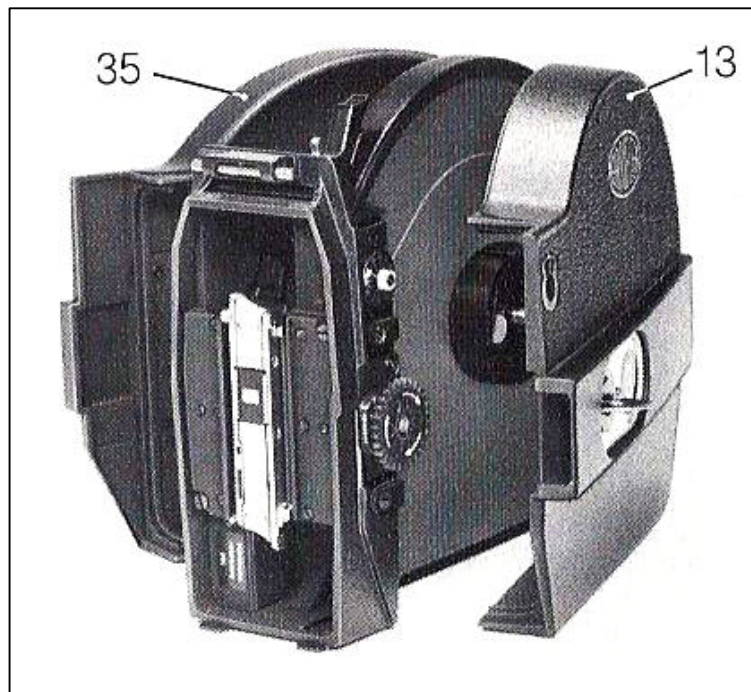

When using raw stock on plastic cores the film core holder (g) is put on the feed shaft, the film roll with the core is pushed onto the film core holder and secured by swinging the flap back and tightening it. Daylight loading spools are placed directly on the feed shaft and also secured.

CARE! Should self-wound rolls be used (e.g. a part of a larger roll of raw stock) *do not* fold the film end over before placing it in the slit of the plastic core as it may jam in the magazine throat or film channel and cause damage.

The film head must always run in the direction of the arrow. Single perforated film is threaded with the perforation to the outside, as shown by the symbol

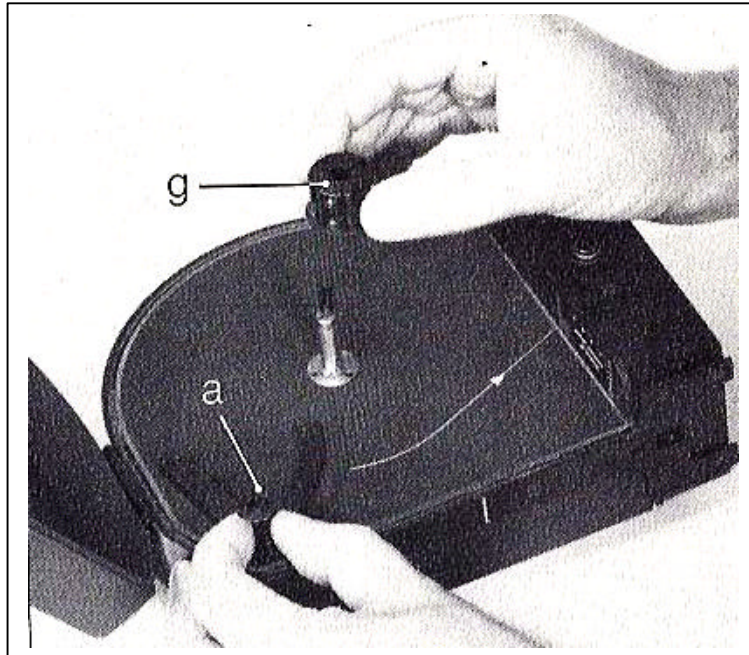

under the threading slot. .Film run in direction of the arrow and the correct positioning of the perforations can only be obtained when "B winding" film is used as previously described.

The pressure roller (a) is then placed onto the film roll so that the film roll is stabilized with the guiding edges; at the same time It also operates the film supply indicator; Not for daylight spools!

Slide the film head, which should be cut straight and through the middle of a perforation hole, into the feed slot of the magazine, turning the magazine gear slightly in the direction of the arrow until a perforation hole is felt to be gripped; push the film on until the film head reappears from the magazine throat above the pressure plate. This operation can be made lighter if the film head is pushed into the feed slot before the film roll or daylight loading spool is fixed to the feed shaft as described above. The magazine lid is then shut and secured by turning the hinged knob (32) to the right.

All further steps can be carried out in the light. The next step is to pull the firm around the magazine until the loop length marker is reached; the wind-up magazine cover (13) is released and opened up and

the exact measured length of film is pushed, without changing its length at all, into the magazine throat of the take-up sprocket until the plastic magazine gear (b) moves in the direction of the arrow. Only then can

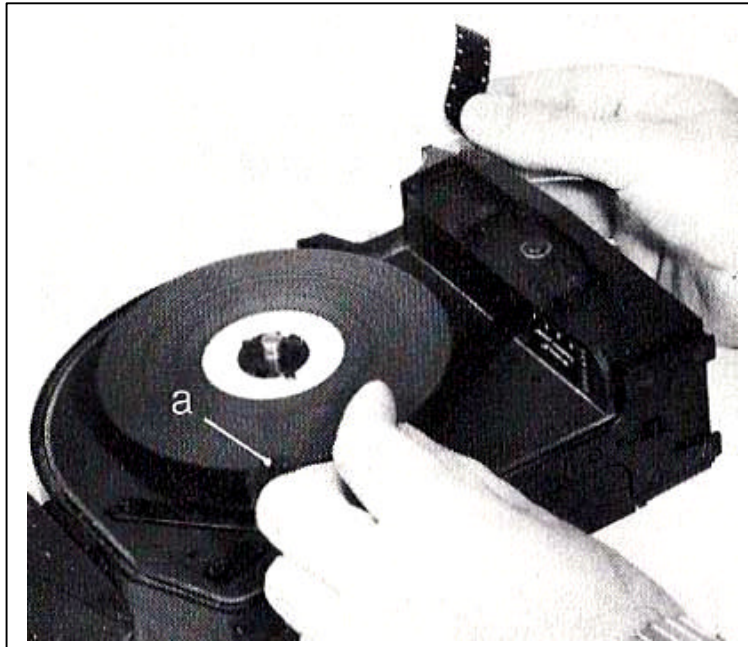

the magazine gear be turned by hand in the same direction {so that the film length remains unchanged} until the film head appears in the take-up area.

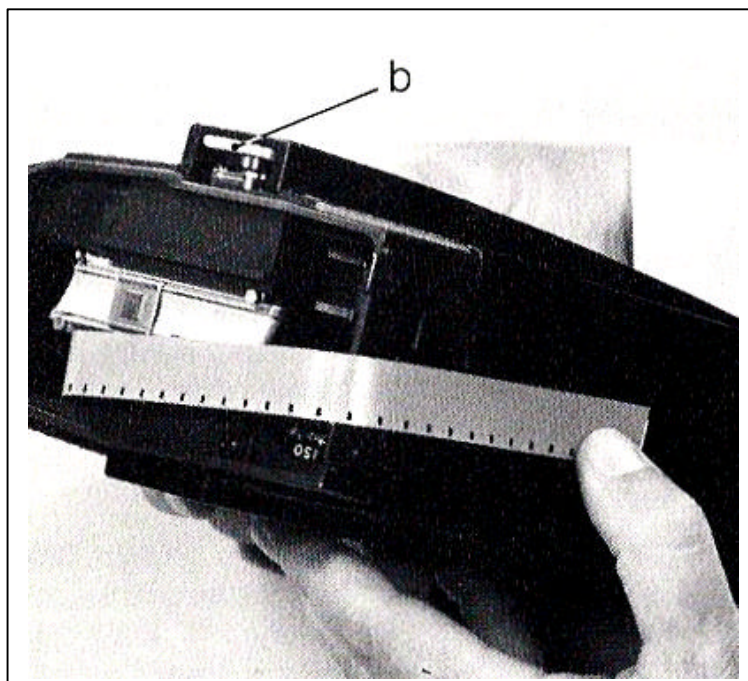

The pressure roller is then swung back and the film is attached to the standard expansion film core (c) in the take-up compartment - (see illustration). Holding the magazine gear stationary, the film core is turned in the direction of the engraved arrow (i.e. clockwise) until the film is taut; the magazine gear is then released and the film core is turned a full turn to ensure that the film is tightly gripped. Finally the pressure roller is swung back into its position so that the edges are in alignment with the film; the magazine cover then is replaced and secured.

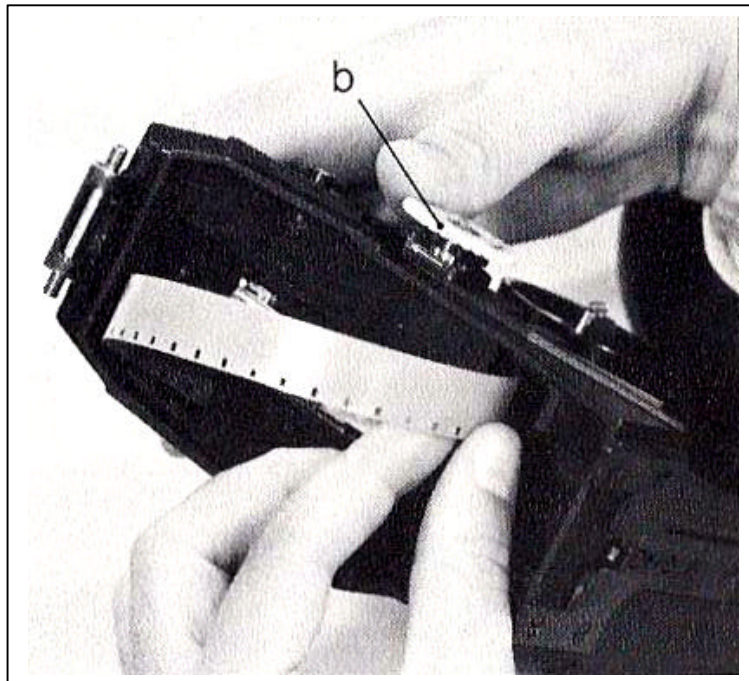

When a plastic film core is used, the standard film holder is pushed onto the wind-up pole until it engages and the plastic film core is then pushed onto it. The slit for fastening the film must point with its pointed corner in the run direction. The film-head should only be folded *once* (NOT several times) and inserted into the film core slit; the film is then made taut as described above.

When using daylight loading spools the film core holder is removed, the film is fixed in the spool column outside of the magazine, a small amount of film is wound up, the spool is set in the magazine and the film is made taut. Unlike in the instructions

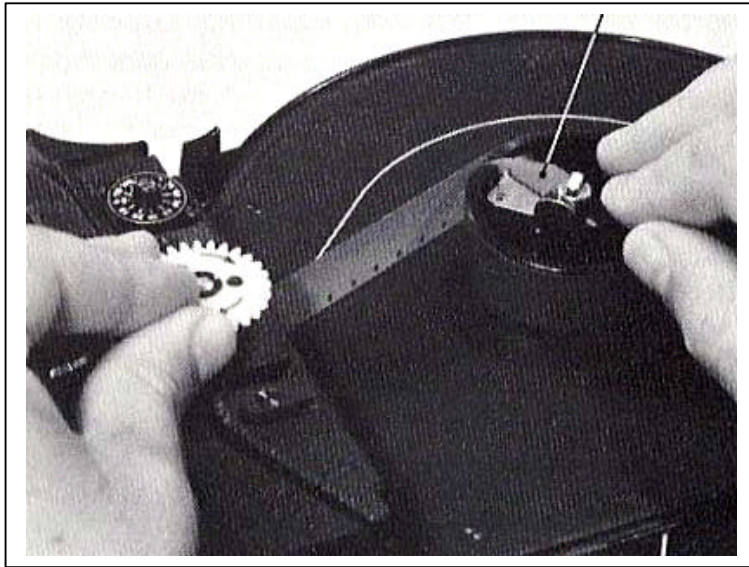

for using raw stock with plastic core, the pressure roller is not swung onto the spool but remains latched away from the spool. In this case the counter works only for the exposed film (12). It must be reset to "0" every time the film is changed.

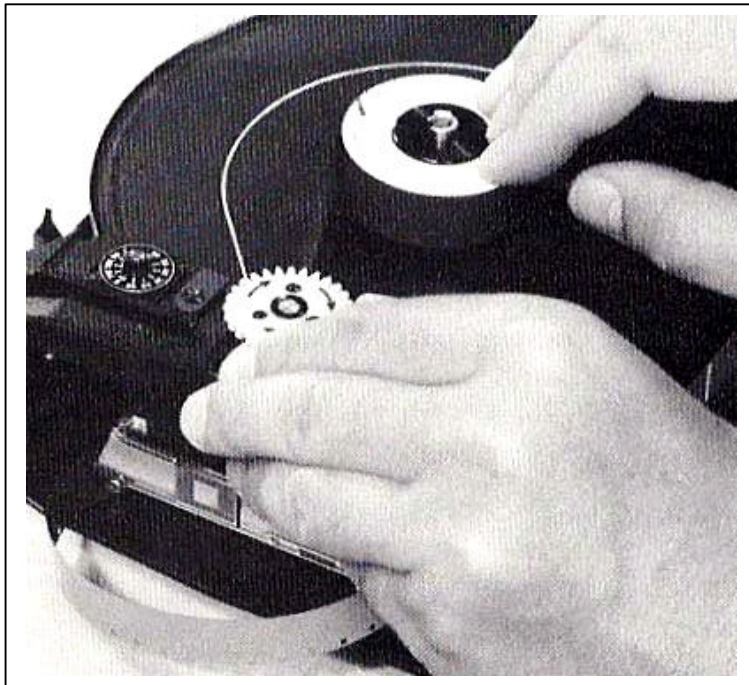



It is important that the film which is slid under the hooks (d) of the sprung pressure plate forms equal sized film loops before and after the pressure plate. (When the magazine is placed on the camera the hooks are no longer in contact with the film).

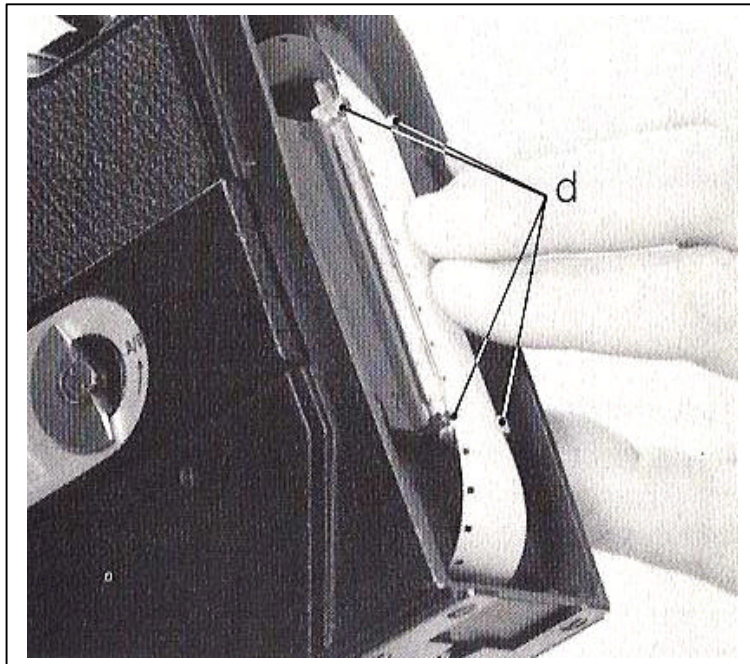

The film aperture cover

When there is no magazine on the camera, the film aperture cover should always be in place. It is easily fixed in position with its snap closure and prevents the film aperture from being damaged or becoming dirty.

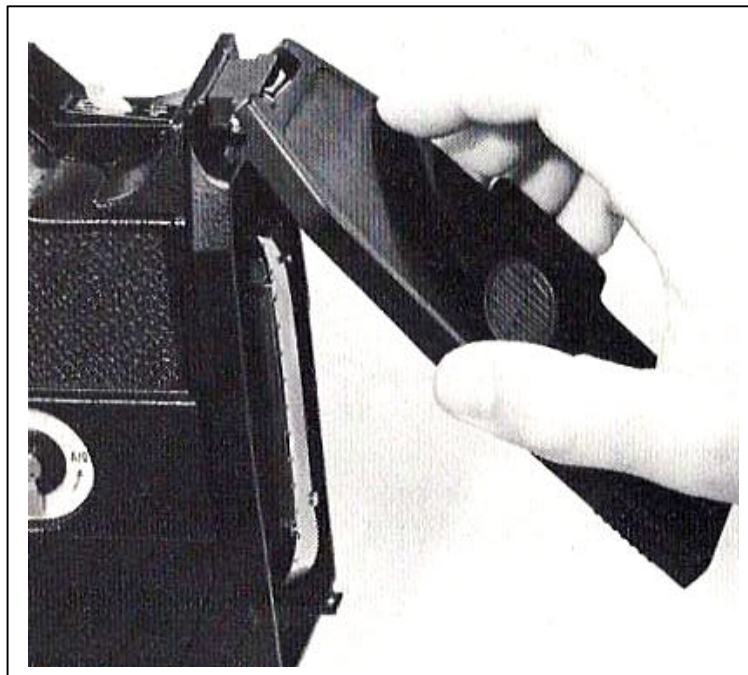

The magazine loop protector

This protects the film loop, the magazine throat and the guide rails from dirt and possible damage. With light pressure it can be swung upwards to the magazine or pulled down again. The loop protector should always be in place on a loaded or empty magazine until it is fixed on the camera.

Removing the exposed film from the magazine

This must take place in a darkroom or in a changing bag. First open the magazine lid (13) by pressing the



safety knob (33) and the same time turning the knob (32) to the left.

The pressure roller is swung back and the film together with plastic core is removed from the film core holder. The film core holder cannot be accidentally removed with the core because it is locked onto the shaft. As with the daylight spools and the expansion film core, the core holder can only be removed when the retaining latch (a) is pushed to the side.

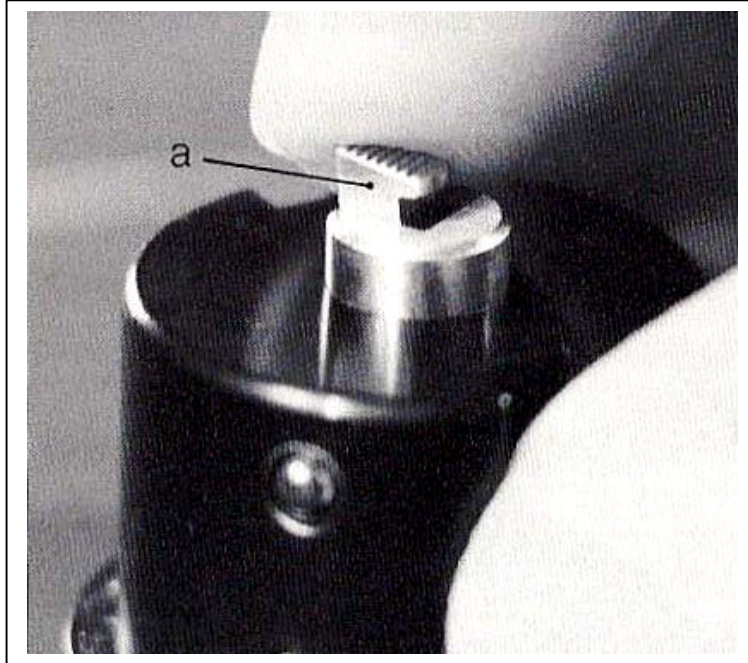

When expansion film cores are used the clamp lever is pressed and the film end is released; at the same time the diameter of the core is decreased so that the film roll can be removed easily. The easiest way to remove the roll is to turn the magazine over and let the film slip out onto the palm of your hand. Place a plastic bobby in the film roll afterwards; it is sufficient to keep the film stabilized even though it sits very loosely. *Under no circumstances whatsoever* should the film be pulled to make it sit tightly on the core as this only leads to scratches on the exposed film.

Counter for exposed film (12)

This works with daylight loading spools as well as with raw stock on a plastic core and must be reset to zero after every film change.

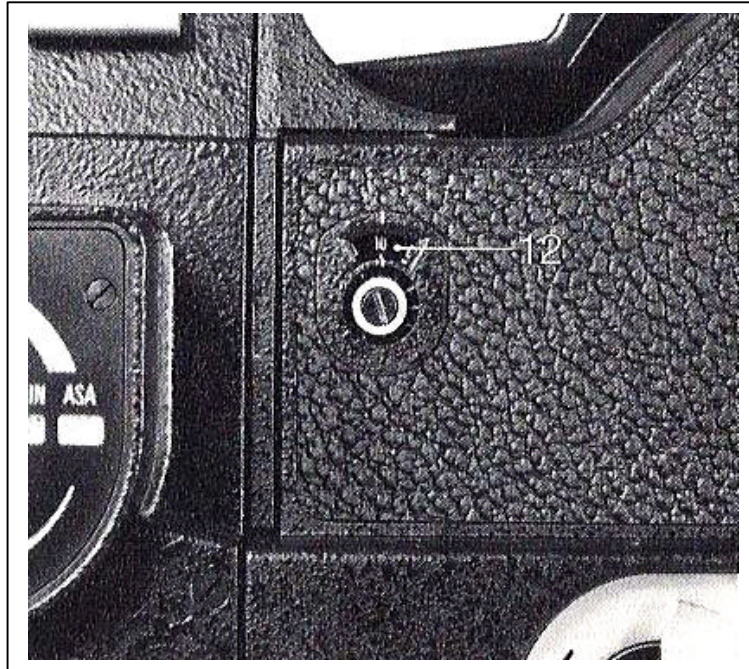

Film supply indicator for raw stock (34)

This works via the pressure roller which rests on the unexposed film and can be read from the back of the magazine.



The functions of the camera release on the housing

The camera release button (28) is coupled with the mirror reflex function so that the camera is quickly ready for shooting.

In the "0" position the camera is switched off and the iris diaphragm (when spring-loaded diaphragm control lenses are used) is fully open. When the release is moved to the measuring position (27), the iris diaphragm will close to the value preselected on the diaphragm ring and the light exposure meter switches on at the same time. The manual adjustment of the iris diaphragm can be carried out now according to the diaphragm aberration shown in the viewfinder image.

When the release is then brought into the "start" position (26), the camera run is switched on. When spring-loaded diaphragm control lenses are used with cameras fitted with a built-in automatic exposure meter, the necessary diaphragm opening is automatically set and can be controlled in the viewfinder.

When the camera is switched off ("0" position), the diaphragm will return to the fully open position. If the camera is again released, the diaphragm will close to the measuring position of the last shot which is stored.

The "memory button"(24) enables the cameraman to retain a momentary f-stop, This is of great value for selective exposure measuring with zoom lenses and for panning, when momentary fluctuations of the automatic exposure control, occasioned by the subject, should be avoided.

When the release {28) is moved in the measuring position (27) and the red knob (a) pressed, the memory button (24) can be pulled downwards (switch on). When the release is returned to the "0" position, the memory button is simultaneously brought upwards and so switched off.

When the release (28) is in the measuring position, it is also possible to swing the retaining lever (25) forwards to restrict the release. The release can now only be moved between "measuring" and "start" positions, for example, when shooting over a long period of time with lenses without spring loaded diaphragm. The iris diaphragm must be manually opened for accurate focusing. The exposure meter is in constant operation as long as it is connected to a battery.

When the retaining lever in the release "0" position is swung forwards, the release is blocked. The camera and the exposure meter can no longer be switched on. This is a safety measure to prevent the camera being accidentally switched on during transport and discharging the battery.

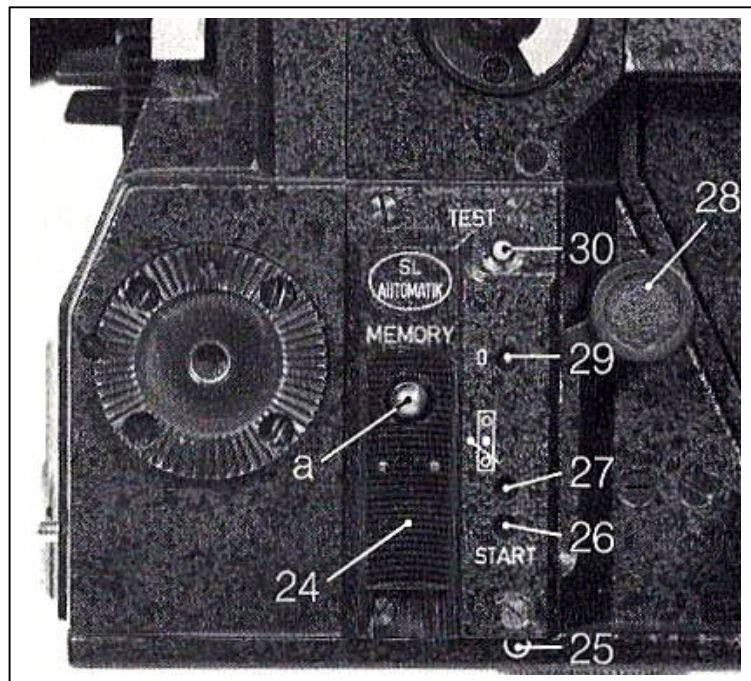

When the camera has been unused for a longer period of time or when it is cold, the inching system should be switched on for a short time to prevent

damage to parts which have become sluggish. The inching system can be switched on by depressing the small red test button (30).

An overload fuse switches the camera off automatically if power consumption exceeds approx. 4.5 A. If this happens, the camera must be switched off with the housing switch and the cause of the overload must be located and eliminated (e.g. film jam) before switching the camera on again.

The drive motor and its electrical control system, pilot tone and start marking.

A quartz controlled 12 V DC motor drives the camera. Frame rates of 24 and 25 fps can be selected (see para.: switching over from 24 - 25 fps, and/or 50 - 60 Hz). Pilot frequencies of between 50 and 60 Hz, proportional to the camera motor speed, can also be selected. Synchronous double system recording is possible with this camera using the following methods:

1. Conventional pilot tone method; including start marking (with cable).
2. Quartz pilot frequency method, without start marking, using a quartz synchronous tape recorder.
3. Quartz synchronous time-coding method.

The current load of the motor is limited to 5 A. The current load at room temperature is about 1 A.

The standard hand grip

The standard hand grip with electrical press button release (59) to start the camera is screwed onto the right hand side of the camera to the rosette (53) and electrically connected with the 4-pole plug (51). The special screw mount allows the handgrip to be adjusted upwards and downwards and to be displaced laterally. The standard hand grip is used mainly when there is no special need in having the combined one hand operation of automatic diaphragm and camera start, or when standard lenses without automatic diaphragm are used.

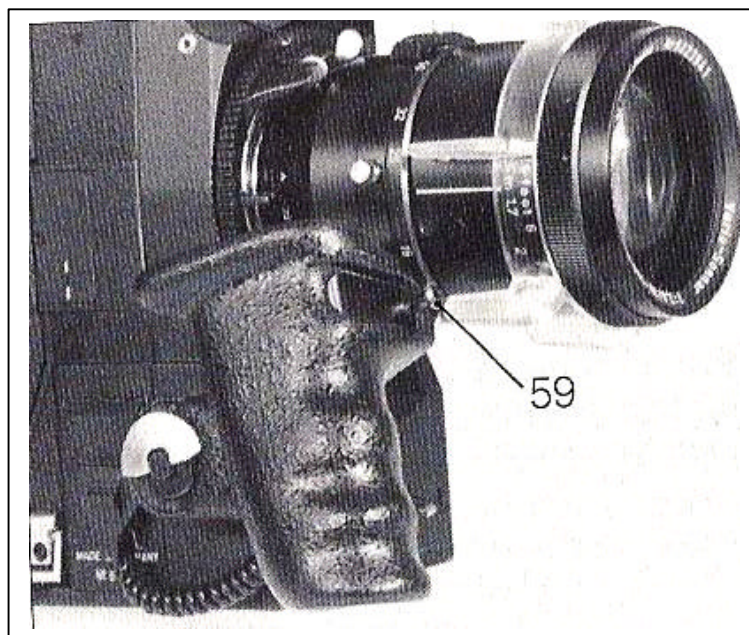

On request we can supply a left hand standard hand- grip which is fixed to the left rosette (22).

To start the camera with the press button release, the camera housing release (28) must be in the measuring position (27) otherwise the camera will not start. This is to prevent unintentional running of the camera with open diaphragm.

The universal handgrip

The universal handgrip with electrical press button release (59) to start the camera and additional cable release (57) to operate the automatic diaphragm, is, like the standard handgrip, fastened to the right-hand side rosette (53) and electrically connected with the 4-pole plug (51). The protecting collar prevents damage to the flexible cable when the camera is carelessly set down. The adjustable universal handgrip is of special use for cameras with automatic exposure control and with lenses with automatic diaphragm. The handgrip rosette should first be positioned in the desired setting and then fixed to the camera. The plug (51) is placed in the socket (52) and then held securely in position with the safety catch. The flexible cable (a) is then pulled back and the square connector plate is pushed upwards into the shoe for the lightweight support

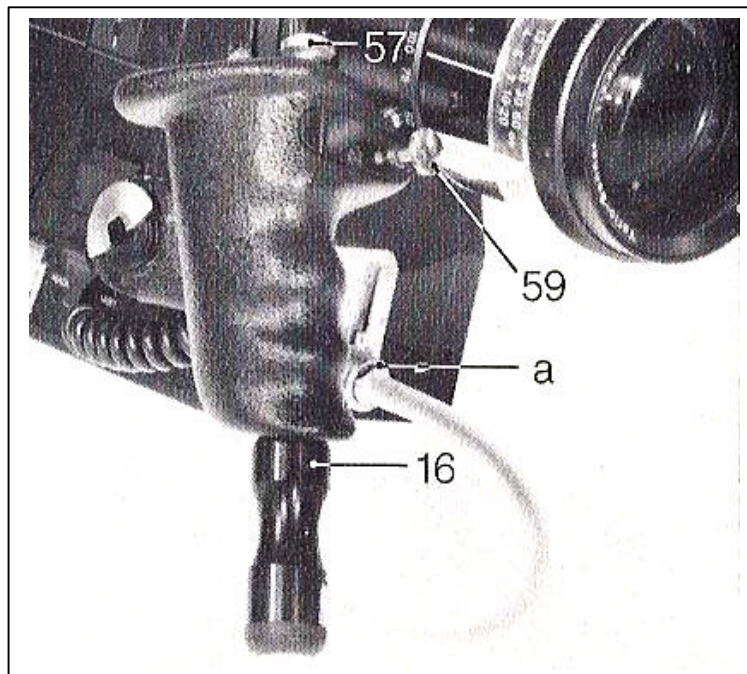

until resistance is felt. Finally, the protecting collar (16) is placed into the handgrip hole until it locks. To remove - follow steps in reverse order.

The press button (57) for operating the automatic diaphragm must be pressed before starting the

camera run as the press button is also a control mechanism against accidental release. At the same time the exposure meter is set in operation. With cameras with automatic exposure meter control and with the lens diaphragm ring set to position "A" (automatic), the iris diaphragm is automatically set according to the lighting conditions. Only then can the camera run be switched on. By pressing the press button release (59) once again it springs back to its previous position, switching the camera run off and releasing the previously pressed button for operating the automatic diaphragm.

The auxiliary handgrip

An auxiliary handgrip is also available; it can be mounted on either the left or the right hand side of the camera and fastened to the rosette. It has no release function and is intended for such situations as when the cameraman needs to be able to hold the camera with both hands. The handgrip can be moved vertically, parallel to the camera, to find the most comfortable position.



The rotating + pivoting viewfinder

The universal application of the camera is backed up by the 16 SR viewfinder (5) which can be turned and swiveled and has fully automatic image compensation. The viewfinder can be turned and swiveled on three planes and it can be used for viewing with the left or the right eye; it can also be steplessly moved from the left to the right end stop and is ready for operation in every position. The viewfinder can also be swung to the side. The three dimensional mobility allows optimal positioning of the viewfinder.

360°

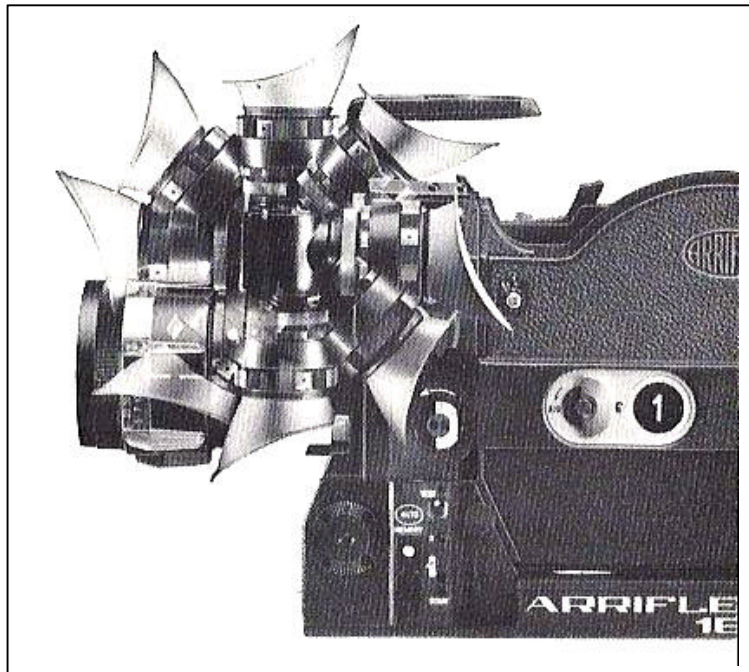

190°

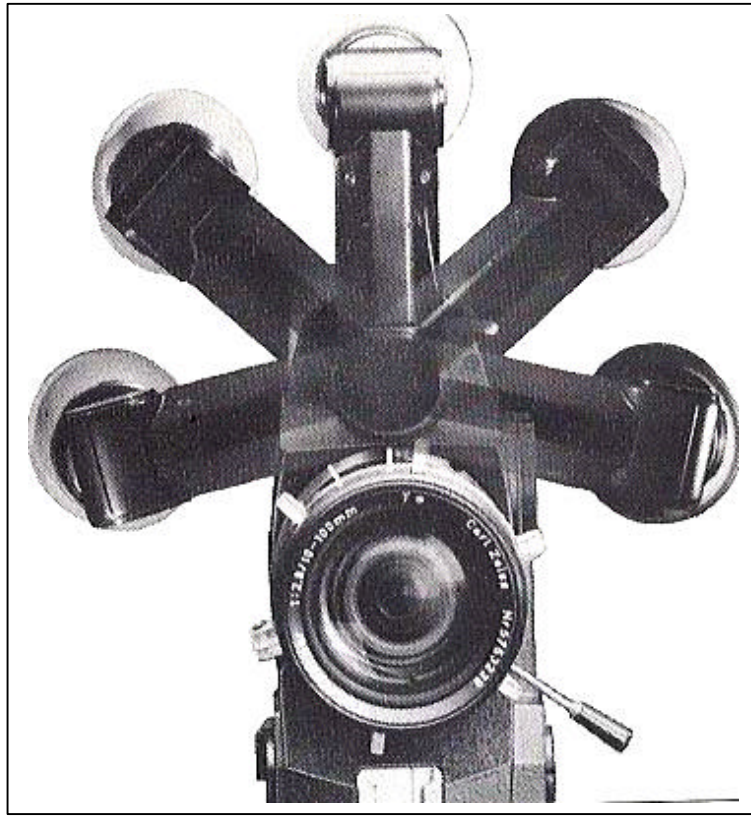

25°

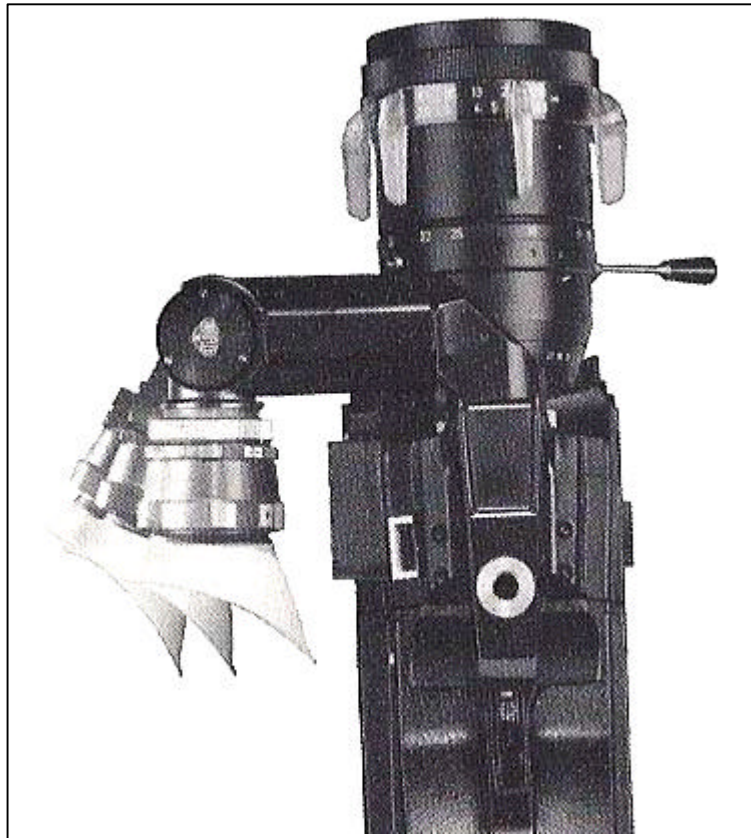

The viewfinder extension is intended for use when shooting from a bird's or worm's eye view, or when shooting from the hip or over obstacles. The extension tube (a) is fitted between the camera and the viewfinder eyepiece. Neither the universal panning/pivoting feature of the viewfinder unit nor the image compensation is affected. As with the viewfinder eyepiece, be careful not to cross-thread the large mounting ring when installing the extension and be sure to seat the locating nipples before tightening.

CARE! The mounting ring has a double thread. If it doesn't tighten easily at once, unscrew and start again. Do not use force. The same care must also be taken when fitting the viewfinder eyepiece.

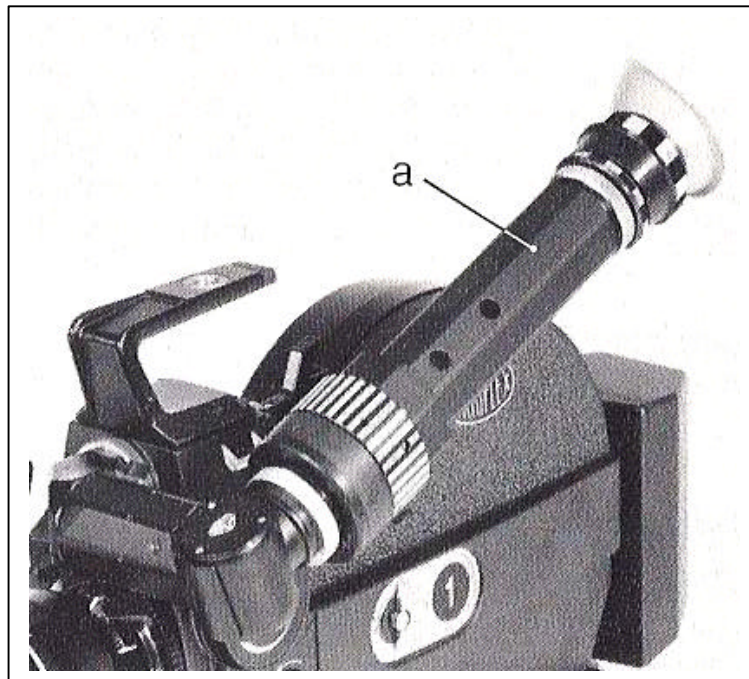

Operating the TTL-Si Exposure Meter

The exposure meter is powered by the camera battery. The measuring range is 13 -31 DIN /16 - 1000 ASA at 5 -75 fps. The film speed is selected by turning the knurled knob (23). The reading field indicator needle is visible in the viewfinder, to the left. When the film speed has been selected, the indicator needle is brought into the center mark by adjusting the iris diaphragm. The two outer Indicator marks, + and -, indicate approximately 2 stops over or under exposure. The indicator is compensated between when stationary and when running, that is, a stop value which is selected before the camera is running need only be changed when the lighting conditions of the scene change. When the camera starts running the indicator jerks slightly, but after one second returns to its previous position. If filters are used there is no need to take them into consideration, as, due to their positioning, they are automatically taken into account. Only when polaroid filters are used must the light be measured beforehand and the filter factor then taken into

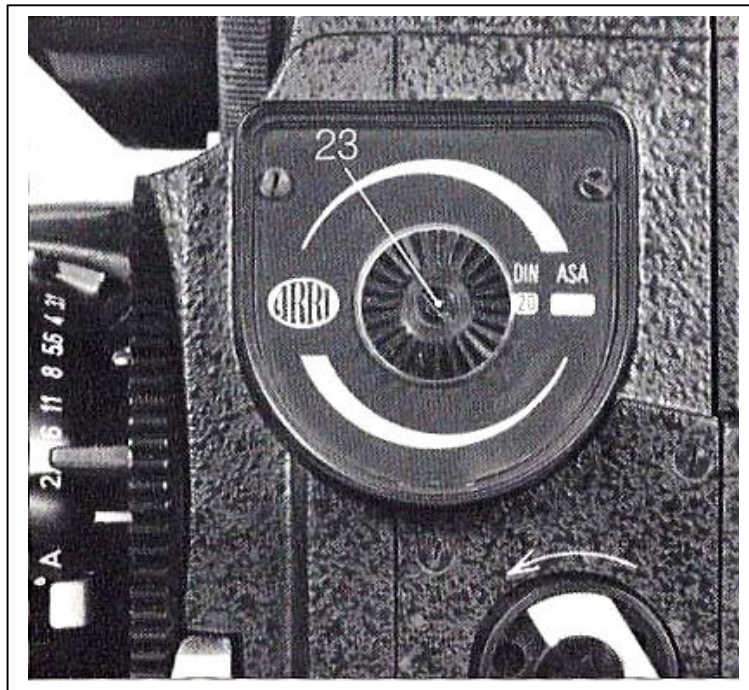

consideration during shooting as polaroid filters affect the light measuring. Regardless of the focal length of the lens used, in this exposure metering system about 25 % of the central image area is measured.

Fully automatic exposure control

The ARRIFLEX 16 SR II is also available with fully automatic exposure control; cameras without this feature can also be fitted with it at a later date.

Automatic iris diaphragm control is only possible with 16 SR spring-load diaphragm lenses (which have a rod to adjust the diaphragm).

The exposure meter is set as previously described.

The change-over to fully automatic exposure control is made on the lens itself by turning the diaphragm ring to index position A. When this is effected; the automatic control circuit is activated when the camera switch is in the measuring position together with the exposure meter. A servo motor in the system moves the iris diaphragm until the optimal setting, controlled through the viewfinder is obtained. When filming with automatic exposure control, the diaphragm ring must remain in position A. If the camera is switched off, the diaphragm automatically opens fully again. As with manual exposure control for speed, the setting is held in a memory. This information is held in the memory until new information is fed to the lens.

When filming with manual exposure control the lens is "locked" to prevent accidental switch-over to position "A" for fully automatic exposure control. On the other hand, the change-over from fully automatic operation to manual exposure measurement is simply achieved by turning the diaphragm ring to 22 without "unlocking". In this way the cameraman can react to special lighting conditions without any delay.

Changing the fibre optic viewing screen

In the 16 SR II instead of the conventional ground glass a fibre optic viewing screen is used to reproduce the reflex image. With the fibre optic viewing screen definition is better, especially with stopped down lenses, as no ground glass grains are visible. The fibre optic viewing screen has markings for film and television formats and light meter scale.

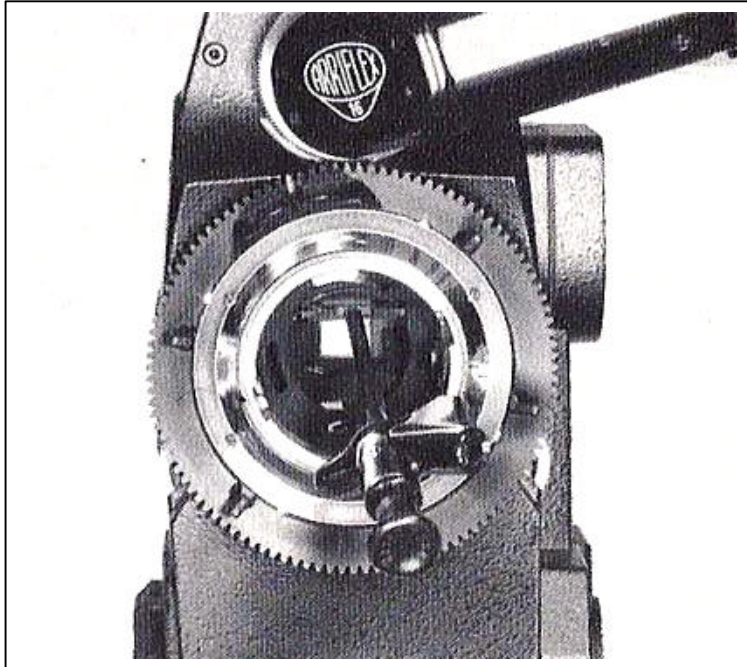

Should it be necessary to remove the fibre optic viewing screen this operation is carried out with a special clamp inserted in the lens bore. Care must be taken when reinserting the fibre optic viewing screen that it is securely seated, otherwise the image reproduced on the film and the image seen in the viewfinder will not be identical.

Lightweight Support

The lightweight support has been constructed as an alternative to the tripod bridge plate, for filming from the shoulder. It is used as a support for the lightweight follow focus system as well as for the bellows matte box and is also used as a support for the lightweight matte box when standard lenses are used.

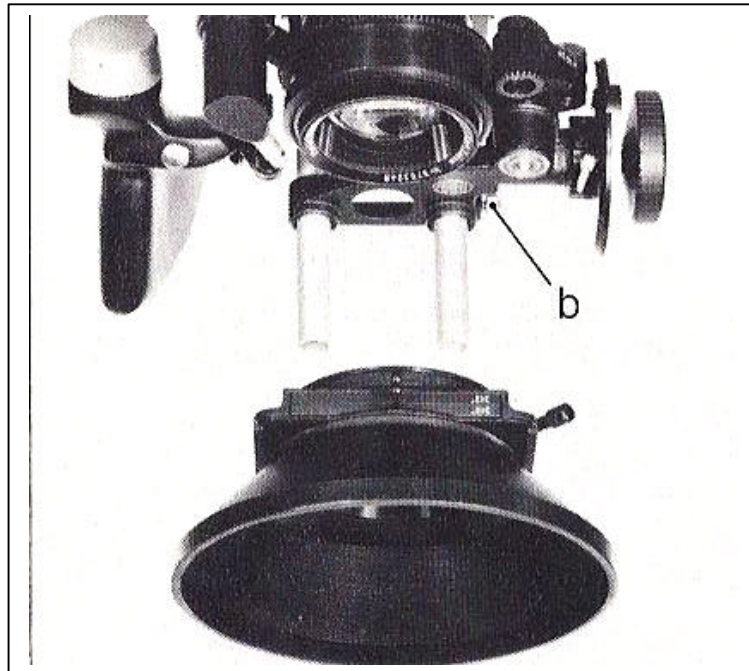

The light-weight support is placed in the camera shoe (19) and fastened with the knurled screw (a) which is found between the two support rods. The accessories can now be pushed on the rods, positioned as required, and held secure by tightening the screw (b).

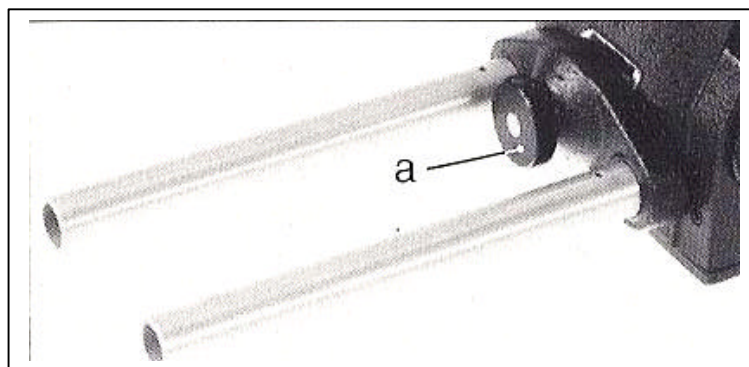

The bridge and support plate

With the bridge plate the cameraman can evenly distribute the weight of the camera when it is being used on a tripod. It is mainly used with extremely long lenses or when several accessories are used at the same time. The base plate (a) of the bridge plate (b), is fastened with the tripod thread to the tripod.

The upper part, to which the camera is secured, can be moved forwards and backwards on the dove-tail guide until the optimal centre of gravity is found, and then fastened. When the clamping lever (c) is released the camera can be removed in seconds from the tripod.

The bridge plate support rods (d) can be adjusted and used to support the following accessories: universal follow focus system, servo zoom, lens supports and the production matte box.

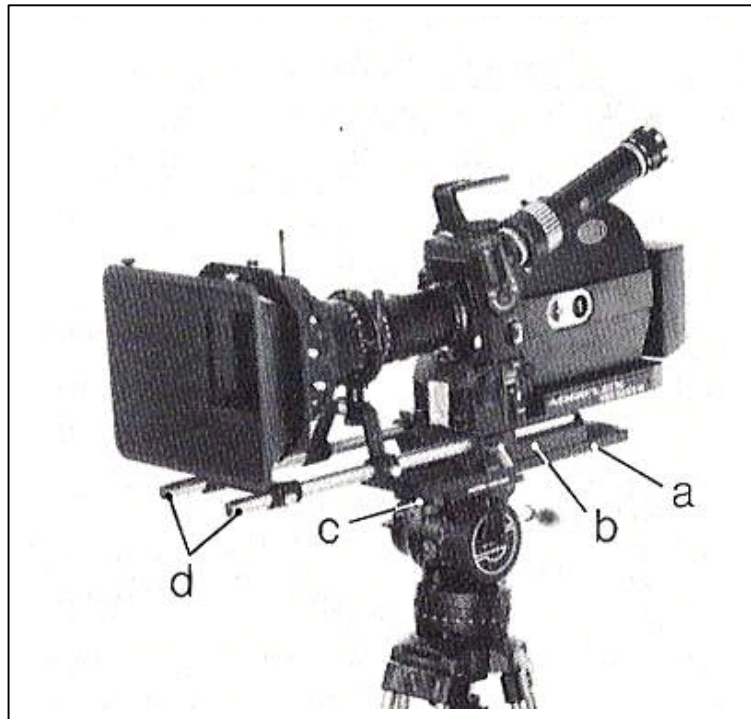

Matte Boxes

In addition to the bellows matte box which was developed for use with the ARRIFLEX 16 SR II (it can also be used with the 35 III), the 16 St bellows matte box can also be used; the old holder must be replaced with a new guide rail which fits onto the lightweight support. Only certain lenses can be used; the 16 St universal matte box cannot be modified.

The bellows matte box is secured in two places: the upper part is fixed to a matte box rod and beneath it is supported on the light-weight support; it is secured in the required position with the screws a, b, c. It has a fixed slot and a rotatable stage for two 3" x 3" or 4" x 4" or 94 mm dia. filters. With the suitable adapter ring this matte box can be used with short focal length lenses (e.g. the 8 mm Distagon) as well as with long focal length lenses (e.g. the 10 - 150 mm Angenieux-Zoom).

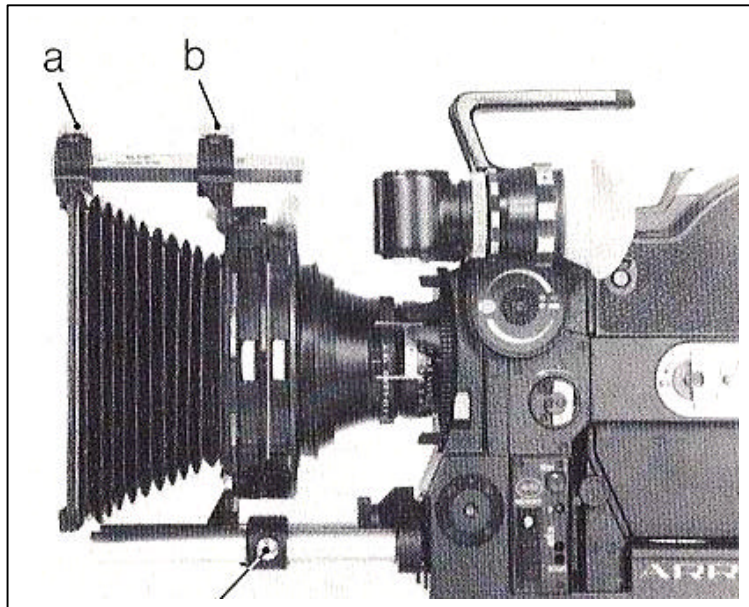

The lightweight matte box is fastened to the front of the lens with a clamp ring. To ensure a close fit there are lens adapter rings for the different lenses. For zoom lenses (with the exception of the Zeiss-Vario-Sonnar f 1.8 / 10 -100) a round rubber hood should be used; for fixed focal length lenses (and the before-mentioned Zeiss-Vario-Sonnar) a rectangular rubber tube should be used. As the lightweight matte box is used mainly for news reporting, a rotatable filter stage is unnecessary. A holder takes two 3" x 3" filter frames. Should the Vario-Sonnar f 2.8/ 10 -100 mm be used, the focus lever can be extended forwards with an extension. With fixed focal length standard lenses which have a rotatable front ring for setting the iris diaphragm, we recommend the use of the additional support for attaching the lightweight matte box to the lightweight support.

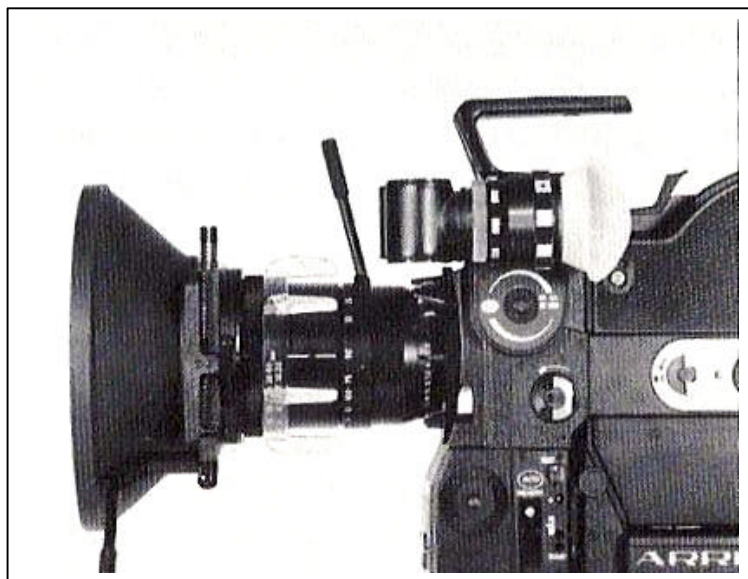

The 4" x 4" production matte box for 16 mm zoom, standard and high speed lenses, with its three filter planes, affords optimal operation versatility for motion picture productions. Two 4" x 4" filter frames are rotatable and slidable for graduated filters. The likewise rotatable filter ring which can be replaced by a reflex prevention ring, is designed to take 4 ½", round filters. The production matte box is fastened to the support rods of the bridge plate (see also »The bridge and support plate«) or the support plate and can be swung away through 90° to change the lens.

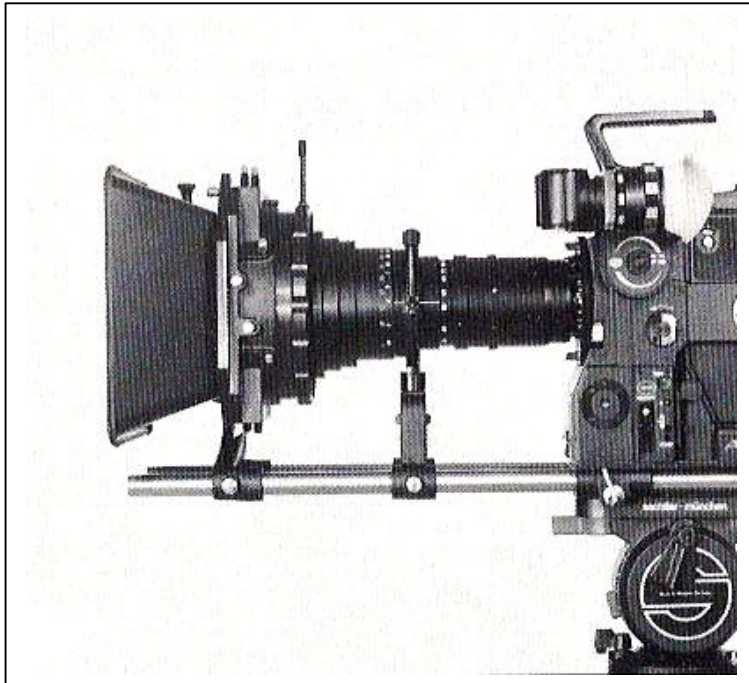

The camera power supply

A 12 V, 1.2 Ah battery is plugged into the back of the camera and requires no cable. At 20°C its capacity is sufficient to expose a maximum of 6 x 120 m of film. When using this battery, a special battery adapter is plugged into the power connection socket (47) and tightened with a screw; the battery is pushed into the adapter and tilted onto the hinges of the magazine. The camera is now ready for operation.

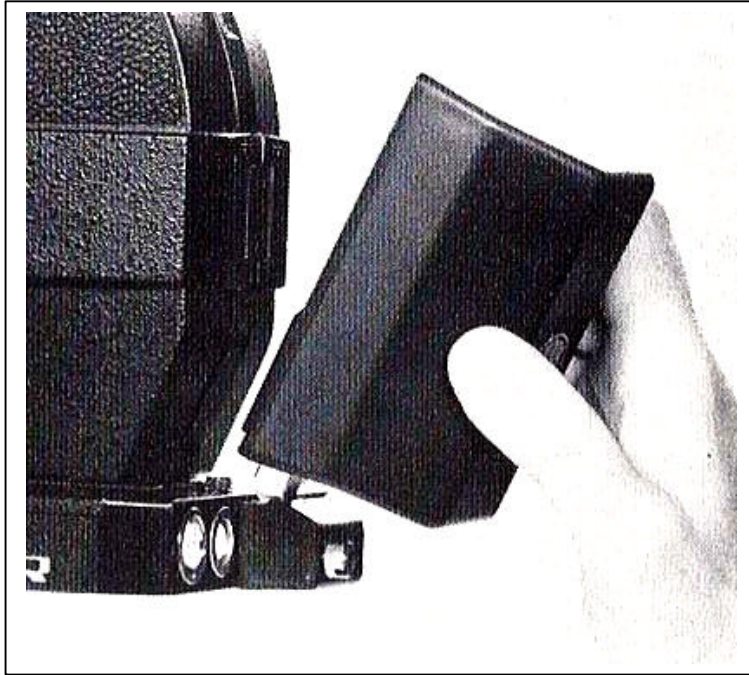

The camera can also be run from a 12 V battery connected with a power cable (mode) KCU). The 4-pole battery connector and its cabling is identical to that used with the ARRIFLEX 16 BLEQ and the ARRIFLEX 35 BL. The camera battery is used to run the quartz controlled drive motor, the exposure meter and automatic diaphragm control as well as all the electrical accessories.

To recharge the plug-in battery there is available the NCL SR II two-output battery charger which is designed for normal and accelerated charging, automatic switch off and automatic 110 / 220 V mains voltage selection.

Also available for the ARRIFLEX 16 SR II is the Energy Set comprised of an NC 12 / 4 E camera battery with a capacity of 4 Ah and a fully insulated NCL 12 / 4 E battery charger with automatic 110 / 220 V mains voltage selection. The charging unit can be switched over from 50 / 60 Hz.

The battery which has a carrying handle, can also be attached to the cameraman's belt or shoulder strap. The compact PPL 12 V high-capacity dry battery is used mainly when battery charging is impossible. It is not rechargeable but has a capacity to expose between 20 -30 120 m rolls of film.

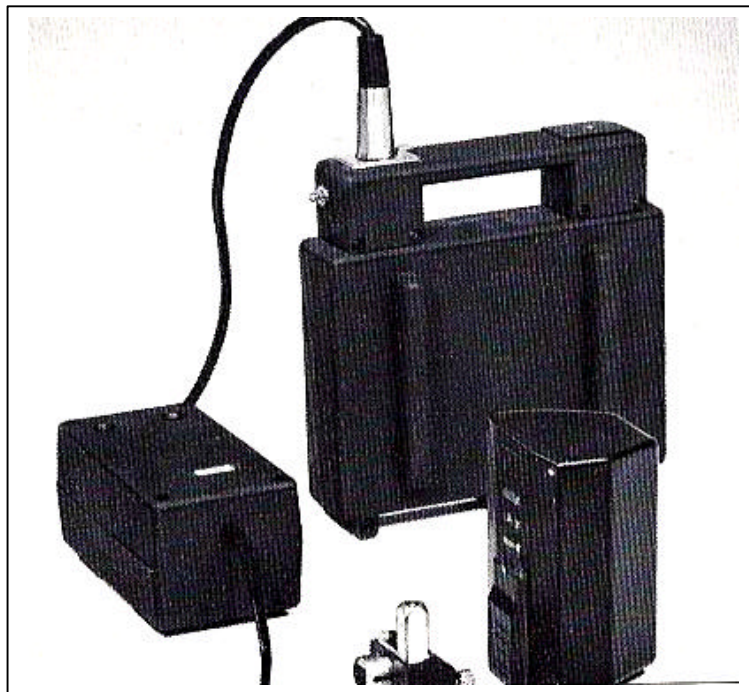

The 16 SR time coding

The ARRIFLEX 16 SR II is optically and mechanically designed to accept the internationally planned (EBU) time coding system.

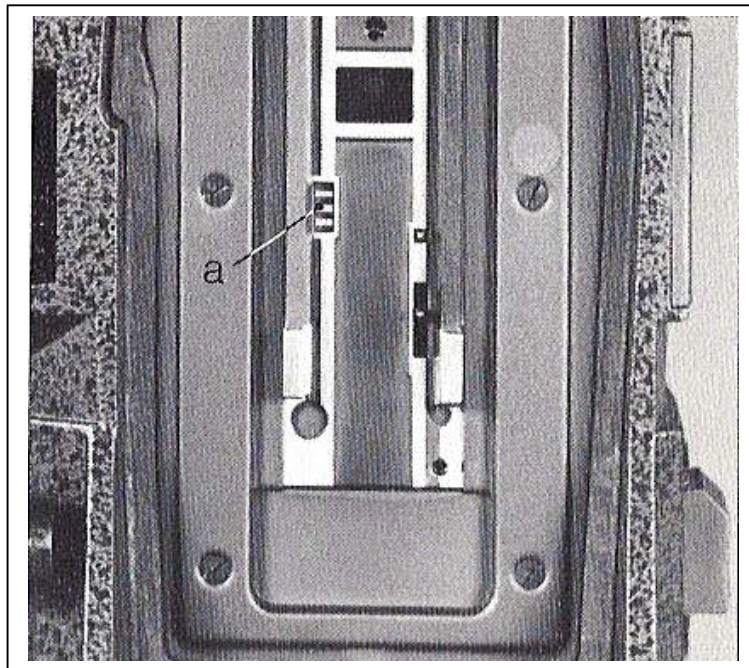

The film is exposed on the opposite side of the claw, two frames below the gate (a).

Plug connections and internal wiring in the camera are already built in for the plug-in, electronically quartz controlled time code system (b).

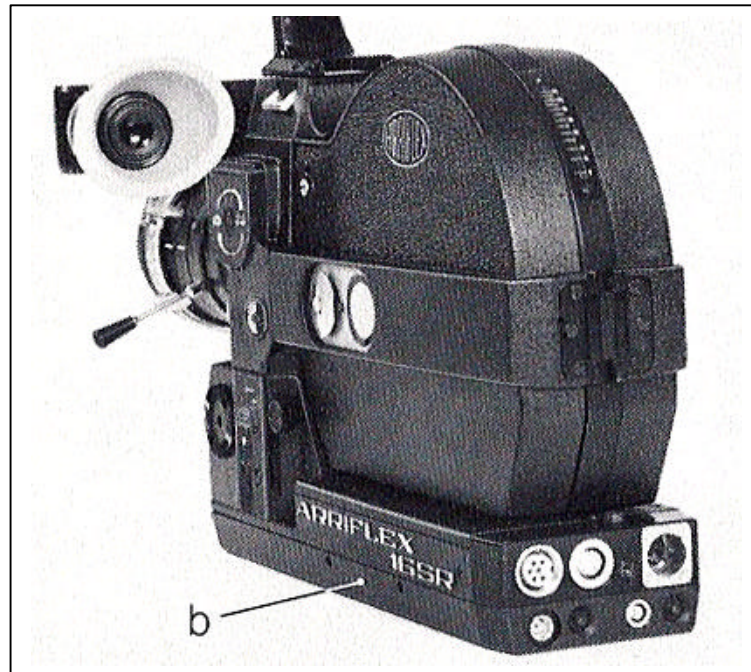

An additional plug connection inside the camera is provided to connect the recorder diode module. This is also used as connector to the conventional full frame start marking lamp, the signal for which is taken from the motor control unit.

Camera speed switch 24/25 fps or 50/60 Hz

The switches are to be found in the camera base plate and are visible when the magazine is removed (48). The switches lie beneath the clear plastic cover (a). This allows one to see if the camera is set for 24 or 25 fps or 50 or 60 Hz. To change over, remove the plastic cover and set as required, then replace the cover. The switch over can, of course, only be effected when the camera is switched off and the battery disconnected from the camera.

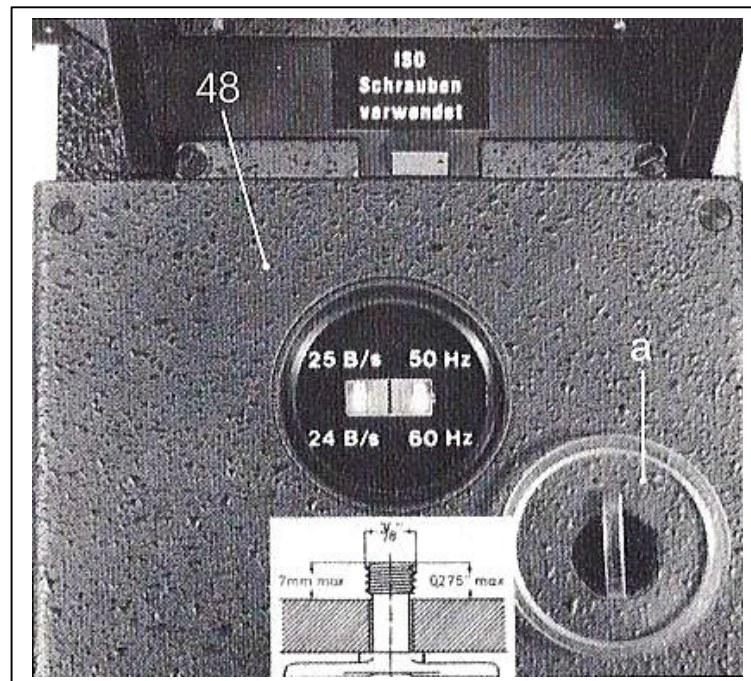

Pilot tone output

On the left side of the rear base is the standard 5-pin pilot tone output (44) for the standard ARRIFLEX pilot tone cable. For all ARRIFLEX cameras there are standard pilot tone cables.

Fuses

To prevent damage to the electronics and the internal camera wiring from short circuiting inside the camera there is an electronic plug-in fuse for the motor control unit.

When the magazine is removed and the battery disconnected from the camera, the plastic cover (b) is removed (with a coin) and the electronic plug-in fuse can easily be removed with a special clamp.

2 reserve fuses are located in the plastic cover . When they are removed from the plastic cover the ends of the fuses must be bent at right angles so that they fit easily in place. Replace the plastic cover and procure new fuses.

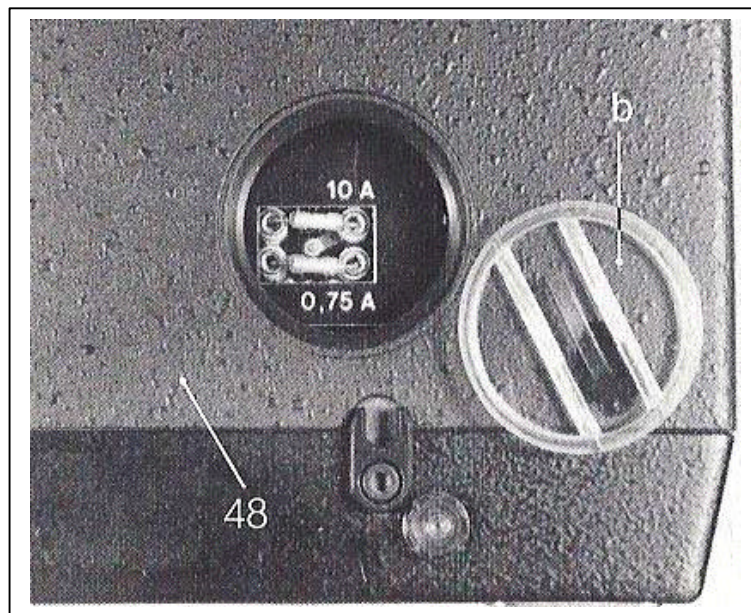

Full frame start marking lamp

The full frame start marking lamp is to be found under a cover plate (50) on which the film plane marking is also engraved.

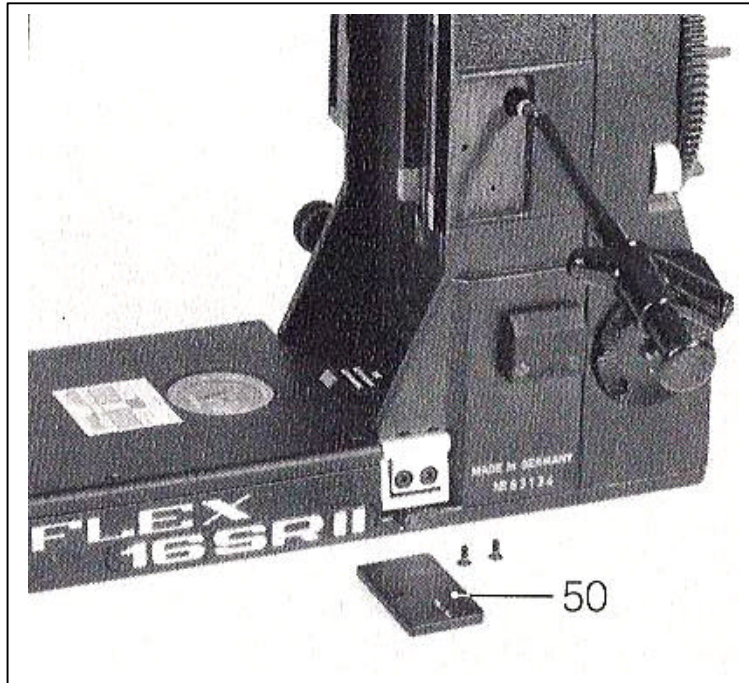

To replace the lamp, first remove both counter sunk screws. When the magazine is removed the cover plate (50) can be lightly pulled up so that the threads for the full frame start marking lamp are visible.

With a special clamp the complete full frame start marking lamp can be lifted out and replaced with a new one. The new lamp must be securely positioned, the cover can then be replaced. The lamps are long-term lamps and are operated at below their rated voltage and so have a service life of several hundred hours. A lamp change should be a seldom occurrence.

Electrical accessories

a) Panhandle switch model RCSR

The panhandle switch can also be used with the ARRI FLEX 35 BL, the 16 BLEQ and the 16 St with universal motor; its cable plug is inserted into the middle socket (45) of the camera's rear plug board and enables the camera to be switched on and off at the panhandle.

The camera can only be started from the panhandle when the camera release (28) is placed in the "measuring position" or the push button (57) on the universal hand grip is operated. This electrical locking function prevents the camera being switched on in error as well as filming with open diaphragm.

b) Variable speed unit (VSU)

The VSU unit, which is attached to the panhandle, is also plugged into the middle socket (45) of the camera's rear plug board. As with the panhandle switch RCSR the camera is also switched on and off by pressing the round button. Close to it is to be found a toggle switch; when in position "cam. ref". (camera reference), the camera operates at a constant quartz controlled speed; when in position "var". (variable) the camera can be operated between 5-75 fps (with the ARRIFLEX 16 SR-HS II, 10 -150 fps).

c) Phase shifter unit PHU

The phase shifter unit is used for correcting the phase relationship of the quartz-controlled camera when filming from television monitors. The connection for the PHU is the middle socket (45) of the camera's rear plug board.

d) The EXS II external synchronizer , The EXS II external synchronizer with BAS signal, built-in remote ON/OFF switch, out-of-synch indicator, camera type selection switch and built-in phase-shifter is used for synchronizing the camera with another camera, with the mains, or with the

BAS signal from a monitor (signal 50/60 Hz, $> 1 V_{pp}$, $< 10 V_{pp}$, signal form sinus or impulse, BAS). The connection for the EXS II is the middle socket (45) of the camera's rear plug board.

e) Remote control unit FSZ II

The remote control unit fulfills all the functions of the above-described control units. Additionally, with this unit, the frame rate can be quartz synchronously set in steps from 6 -75 fps. External synchronization is also possible at 25, 50 and 75 fps, permitting synchronization with the lighting supply mains.

For mains synchronization with the FSZ If or the EXS II the mains sync transformer NSYTR 2 for primary 220 V, secondary 1 V sec is necessary.

Any two of the above-mentioned external accessories can be connected simultaneously to the camera with *the ZV accessory connector board*.

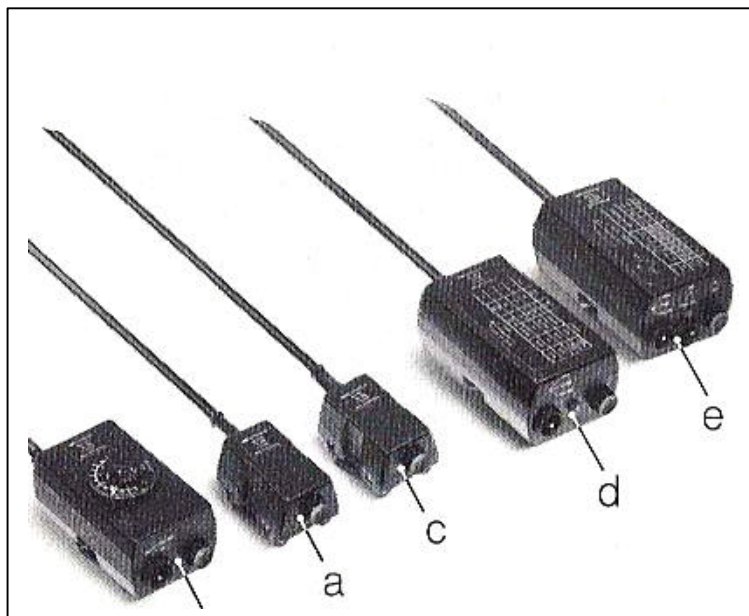

The ARRIFLEX Image Stabilizer

When this accessory is used a steady, upright image can be produced in the viewfinder and on the film in situations when the camera is shaken and jolted.

The Stabilizer is light and so is ideally suited for hand-held shots. The Stabilizer works on a gyro-scope principle which must be borne in mind when panning the camera. The maximum panning speed is $4^{\circ}/\text{sec}$. The Stabilizer can be used horizontally or vertically; it is fixed onto the bridge plate rods and, according to the length of the lens used, is held in position with a clamp screw. The ARRI light-weight matte box provides sufficient shade; if required, an additional light-weight matte box holder can be mounted on the rear clamp ring of the Stabilizer for inserting filters between the lens and the Stabilizer.



Adaptation of a Video System

The video adaptation enables the director and others working on the production to view the finder image, before and during shooting, independently of the cameraman, on any desired number of monitors in accurately framed, true perspective. The rotating and pivoting viewfinder is replaced with the video

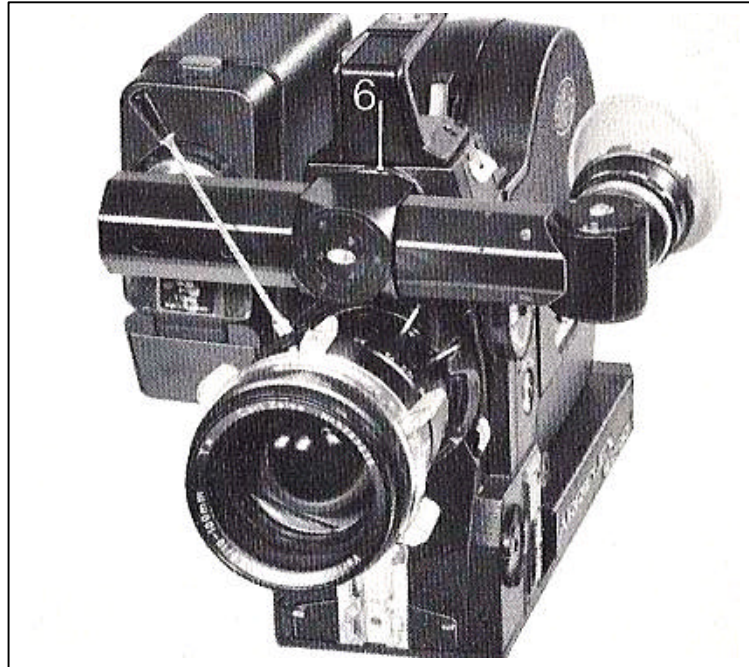

adaptation and is fastened with the collar nut (6). To remove the rotating and pivoting viewfinder, unscrew the chrome plated cover plate with engraved index markings and then remove the geared catch ring (4); then loosen the bushing (A) with a special wrench (S 16 SR-3) and turn the worm (friction adjustment) about ten turns anti-clockwise with a hex socket screw driver SW 2 (A 16 SR-16). The bushing can now be removed and the worm also after a few anti-clockwise turns more. The collar nut is unscrewed (6), the viewfinder being held securely. The viewfinder can now be pulled out forwards; the friction disc (pertainax ring) between the viewfinder

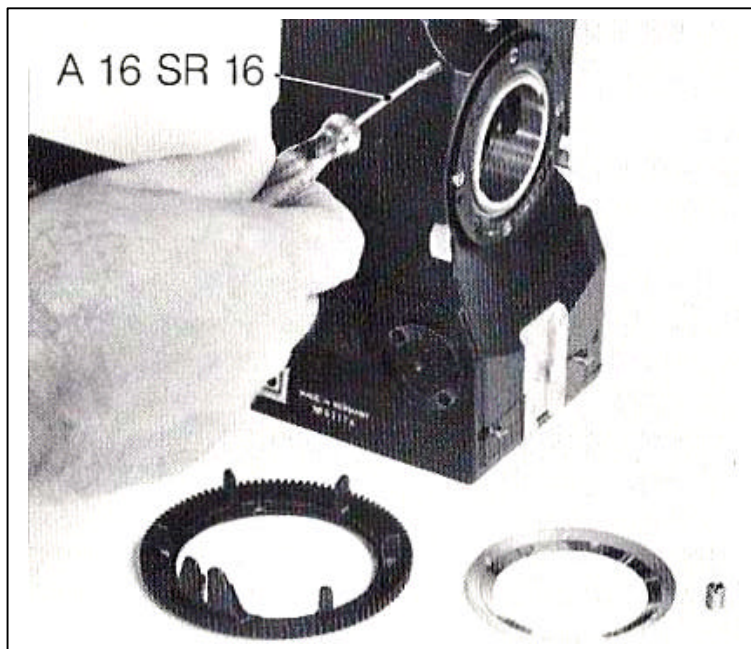
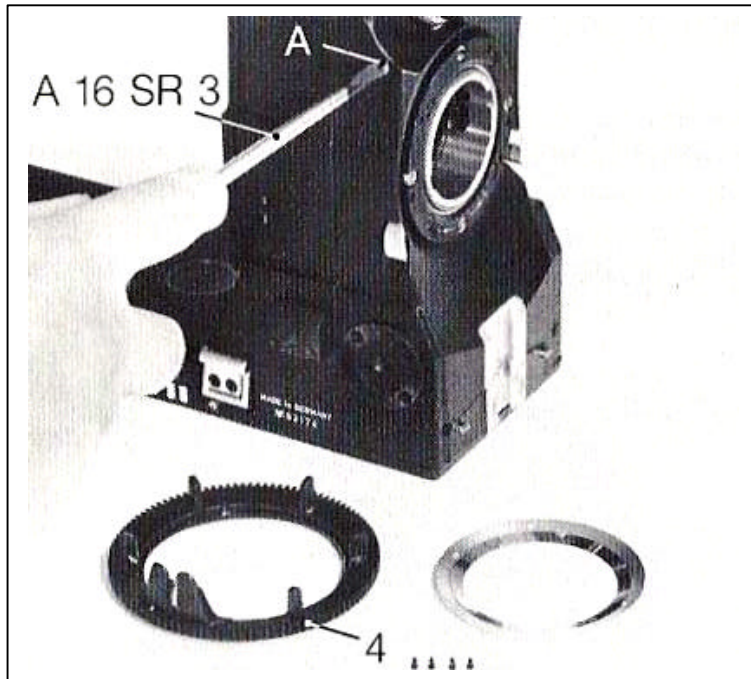

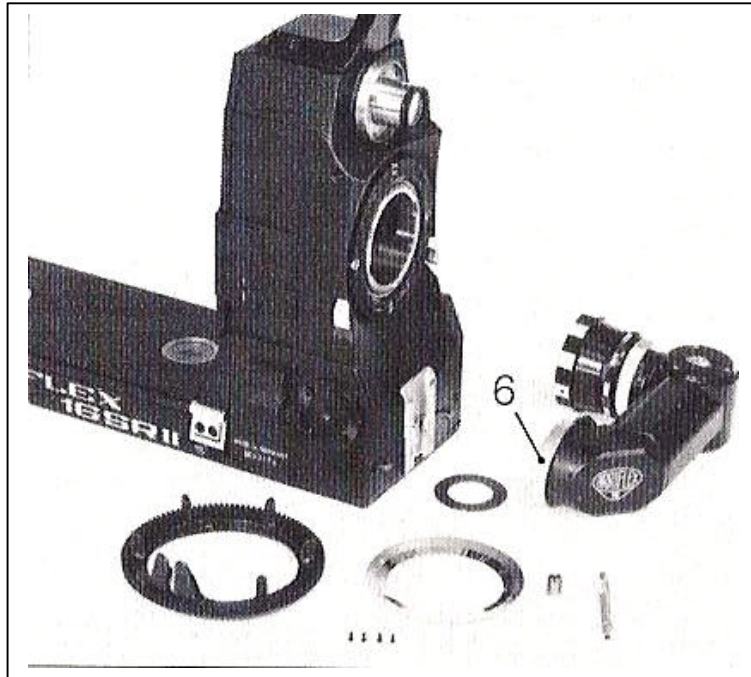

and the primary optics must also be removed. The video adaptation is mounted reversing the above-described steps. The friction disc is not used. Care must be taken that the adapter arm for securing the viewfinder (seen in taking direction) is on the left side of the camera housing. It is not possible to turn the video adaptation through 180° for left eye viewing.

EFC 16 SR Digital Counter

The frame speed and amount of film exposed in meters (or in feet with the alternative model) can be read from the new EFC 16 SR digital counter. The counter can be adapted to cameras with 24 fps or, alternatively, 25 fps. A memory, powered with a battery lasting approximately six months, retains the amount of film exposed when the camera is



separated from its battery. The EFC-16 SR can be connected directly via a cable with the camera's electronic shoe. (Socket 45); when the VSU is used with the EFC-16 SR, the accessory distributor ZV is necessary. The counter is attached to the additional thread (40) on the camera carrying handle; the ball and socket joint connection enables the EFC-16 SR to be positioned in any direction for easy reading.

Film plane indicator

The film plane indicator (50) is used for precise evaluation of the taking distance, with close shots, between the camera and the subject or for deciding the distance for the microphone. The indicator is engraved in the cover of the full frame start marking lamp which is found on the right hand side of the camera (seen in taking direction).

The asynchronous diode

When the camera is started at the right of the view- finder image a red dot is visible which disappears after a short time. This is a signal sent by the asynchronous diode, and the signal remains until the selected frame speed is reached. Should the voltage drop the dot also appears and is so an indication that the battery must be exchanged. In this case the rear red control lamp no longer blinks but emits a steady, weak light.

The time counter

The time counter, when the camera is fitted with this function, is to be found above the 4-pole plug (51). It is a graded rod in which there is a mercury column with marker. When the camera is operated for 100 hours the marker travels from left to right, and then travels in the opposite direction in the next 100 hours of operation. The exact operating time of the camera can be determined and controlled.

Service

For a trouble-free film run, especially with regards to steadiness of image, the camera side film channel must be kept absolutely clean. Always check that no emulsion deposit has built up. Emulsion deposits on the film gate can alter film focal distance which, when lenses with a very short focal length are used, can lead to unsharpness.

The film channel is easily accessible and can be cleaned with a PVC rod. We recommend the use of the ARRI plastic film track cleaning rod. Under no circumstances attempt to use metal or other hard tools.

The function of the magazine film guide is also of great importance. Special care must be taken of the film pressure block. When the magazine is placed on the camera this automatically forms a protective film guide. The film is pressed against the pressure gate with a carefully measured force. To adjust this force, a special unit is necessary which also can be used to control the movement of the pressure block.

Apart from, these steps, the ARRIFLEX 16 SR II is basically maintenance free. Neither oil nor grease is necessary;

Authorized ARRI repair shops are available for Servicing.

Breakdown help when the automatic diaphragm and shutter drive are defective

Should the servo motor used for the automatic diaphragm setting become defective, the automatic and iris shutter functions can still be operated when the following steps are taken:

First remove the magazine from the camera (see changing 120 m magazine) so that the film channel is visible.

Then remove the black round sticker (a) which is found to the right of the film channel on the cover plate. Beneath it is a screw; turn it clockwise through approx. 90° and replace the sticker.

The camera can now be used again and the automatic diaphragm function is again operative.

The iris shutter f-stop must however-be manually set in conjunction with the manual exposure meter.

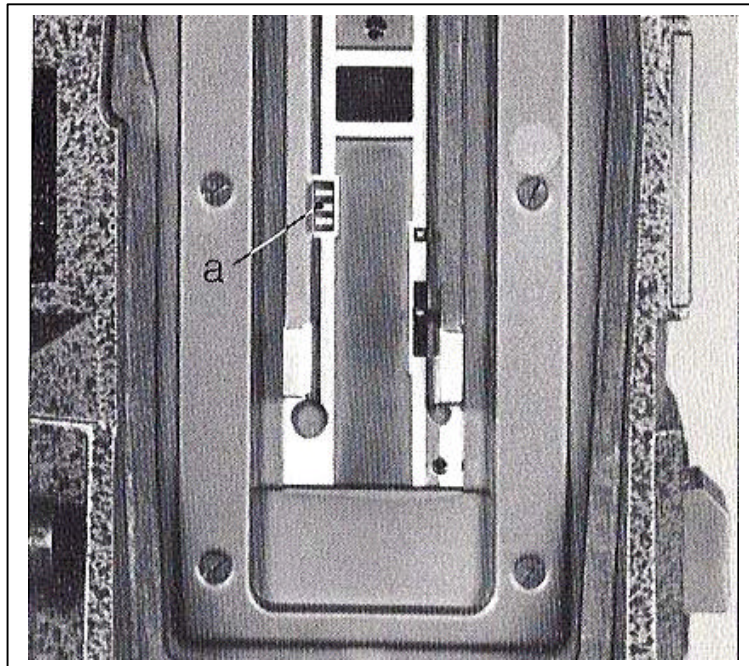

Technical data

ARRIFLEX 16 SR II/16 SR-HS II

Measurement

Length: measured from lens flange

Viewfinder horizontal L x H x W 264 x 195 x 160mm

Viewfinder vertical L x H x W 264 x 287 x 100
mm

Weight

Camera body, 3,2 kg (7.05 lbs)

120 m magazine 2,2 kg (4.85 lbs)

Magazine

120 m coaxial quick-change magazine for use with film on plastic bobby, "Winding B" or (with increased noise level) 60 m daylight loading spools; hinged lid

Film movement ,

Kinematic, jointed pulldown; registration pin; image steadiness is 1‰ of frame height. Registration pin position + 3

Shutter

180° one-piece, mirror shutter intersects optical axis 9 mm before the focal plane at 45°, reflection upwards

Noise level

16 SR II 25 + 1 dB (A)

16 SA-HS II 32 dB (A) at 24 fps, 56 dB (A) at 150 fps

Lens mounting flange

Steel bayonet, flange focal distance 52 mm, opening 41 mm

Lenses

All standard unblimped ARRIFLEX 16 BL lenses can be used

Viewfinder

Universally adjustable with automatic image compensation, removable eyepiece, 10 fold magnification

Focussing screen

Interchangeable fibre optic screen for TV or cinema format .

Exposure control

Electronically governed. Data input only for film speeds 13-31 DIN /1000 ASA. Indication range ± 2 stops

Fully automatic exposure control

Available with or without automatic exposure control, suitable for later fitting for fully automatic exposure control

Power

12 Volt, Connector: 4-pin DIN 15931

Plug.in battery

12 Volt,-1,2 Ah

Camera motor

DC quartz precision motor, 1500 rpm at 25 fps, 1440 rpm at 24 fps, quartz accuracy 5×10^{-6}

Frame speeds

Quartz 24/25 fps

Manual speed control

With variable speed unit (VSU) Variable 5 -75 fps (16 SR-HS II 10- 150 fps)

Power consumption

Approx. 1 Amp at room temperature

Safety

Overload switch cuts off power when load exceeds approx. 4.5 Amps.

Release

2 step release for diaphragm operation

Temp. range

-20°C to + 50°C (-4°C to + 122°F)

Pilot tone

Pilot tone supply DIN 15575, pilot frequency 50 or 60 Hz

Start marking

Automatic full frame start marking

Time Code

Prepared to accept a time code generator

The ARRIFLEX 16 SR-HS II

The ARRIFLEX 16 SR-HS II is a development of the 16SR-HS. The exposure control system is the same as in the 16 SR II, the automatic exposure control is, however, a standard fixture.

Both manual exposure control and automatic exposure control (when using lenses with spring loaded diaphragm) can thus be used, The frame speed of the 16 SR-HS II can be adjusted steplessly from 10 -150 fps with the Variable Speed Unit (VSU). There is a special scale graded from 10 - 150 fps available for use with the VSU, but the standard 16 SR II scale graded from 5 -75 fps can also be used; the set reading need only be doubled to obtain the actual frame speed. With the exposure meter, the frame speed is automatically taken into account.

The noise level, at 25 fps 32 dB (A) and at 150 fps 56 dB (A), is relatively low.

A trouble-free run for the complete frame speed range can only be guaranteed when the threaded film is not colder than -5°C (23°F). The camera is also fitted with a rev limiter which automatically switches the camera off when a speed of 165 fps is reached. With the exception of the magazines, the complete range of the 16 SR mechanical, optical, electronic and electrical accessories can be used with the 16 SR-HS II.

The standard magazines for the 16 SR II are built with a spring-loaded pressure plate and for a focal plane measurement of 52 mm. The 16 SR-HS II needs a special magazine with a rigid pressure gate and the high speed film run makes a film channel with a focal plane measurement of 51,970 mm necessary. To avoid confusion with the magazines, the 16SR-HS II magazines are finished in an attractive grey.