

# 35R3

---

## OPERATION & SERVICE MANUAL

---

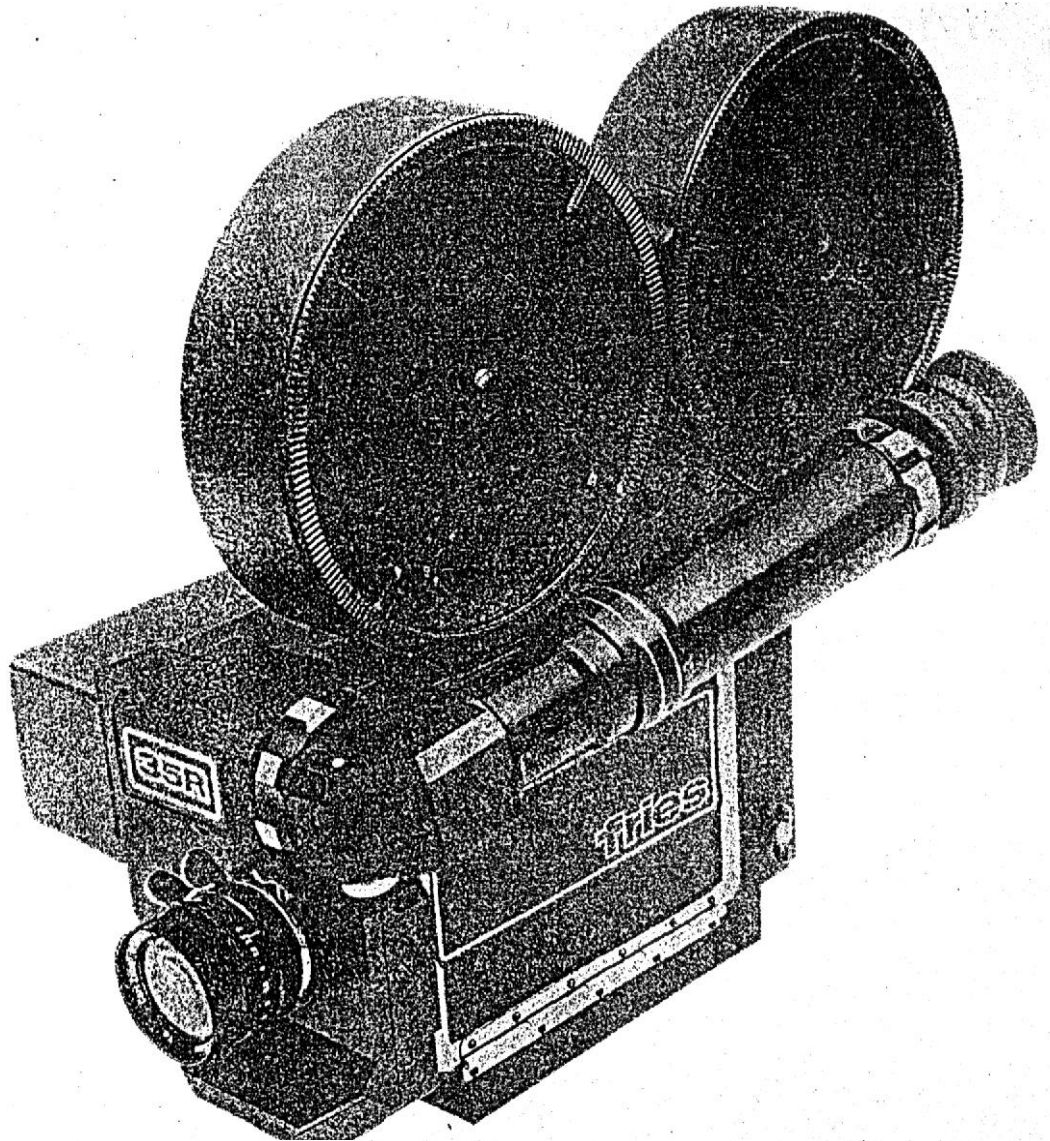

---

Fries Engineering, Inc.  
12032 Vose Street  
North Hollywood, California 91605  
Phone 818-765-3600 Telex 4720922

**fries**  
Engineering inc.

OPERATION AND SERVICE MANUAL

FRIES 35R3 ROTARY MIRROR CONVERSION TO MITCHELL GC HIGH SPEED  
35MM MOTION PICTURE CAMERA

Fries Engineering, Inc., 12032 Vose Street, North Hollywood, California 91605  
Phone (818) 765-3600 Telex 4720922

## CONTENTS

SECTION I	<u>DESCRIPTION</u>	
	General .....	1
	Camera Box .....	1
	Orientable Viewfinder .....	2
	Film Clip and Register Pins .....	3
	Changing Groundglass .....	3
	Film Clip .....	4
	High Speed Movement..... <sup>†</sup> ....	4
	Shutter .....	5
	Footage Counter .....	5
	Magazines .....	5
	Lenses .....	6
	Camera Dimensions and Mounting. ....	6
	Camera Accessories .....	6
SECTION II	<u>OPERATION</u>	
	Loading Magazine .....	8
	Changing Magazine Drive Belt.....	8
	Threading the Camera .....	10
	Film Buckling .....	11
	Changing Lensmount .....	12
	Groundglasses .....	13
	Film Clip .....	13
	Footage Counter .....	13
	Matte Box .....	13
	Video Assist .....	14

CONTENTS CONTINUED

SECTION III

MAINTENANCE

Cleaning Camera Box.....	17
Cleaning the Mirror.....	17
Cleaning the Pressure Plate.....	18
Cleaning Aperture Plate.....	18
Cleaning Film Movement.....	19
Timing the Movement.....	21
Checking Timing.....	21.....
Lubrication.....	22.....

## SECTION 1 - Description

### GENERAL DESCRIPTION

The Fries 35R3 is a reflex conversion to the Mitchell Standard/High Speed camera. The Mitchell was chosen for its world famous steadiness, reliability, and high speed capabilities. To meet the various requirements of modern day special effects and commercial productions, a modular design has been incorporated. This allows the cameraman the freedom of choice of lenses, lens centering, motors, video assists, etc., and at the same time the conveniences of a modern reflex camera.

### CAMERA BOX

The camera box is divided longitudinally into two compartments. The left-hand, or operating side contains the film moving mechanism and the intermittent movement. The right-hand side contains the camera driving mechanism. The operating side has a door hinged at the bottom. On top of the camera is a recessed plate for attaching the film magazine and an opening through which the film is drawn from the magazine to the film compartment of the camera. A dust plate is provided to cover this opening when a magazine **is not in place**. The magazine drive assembly is located on top of the camera box.

Film is drawn from the magazine and fed to the movement by a sprocket with 32 teeth. The film is held against the sprocket by two sprocket guide assemblies. A buckle trip is provided to stop the camera immediately in case of film take-up failure. The buckle trip lever actuates a film buckle switch in the camera motor door, cutting off the power.

## ORIENTABLE VIEWFINDER

The entire viewfinder can be adjusted through  $360^\circ$  of rotation.

To adjust: Loosen the viewfinder locking ring by turning counterclockwise (it should not be necessary to loosen by more than  $1/4$  of a turn), position viewfinder, and tighten locking ring by turning clockwise.

NOTE: The viewfinder rotation locking ring should never be tightened more than "finger tight".

The image must be reoriented with every new viewfinder position. To adjust, rotate orientation adjusting ring until image is horizontal.

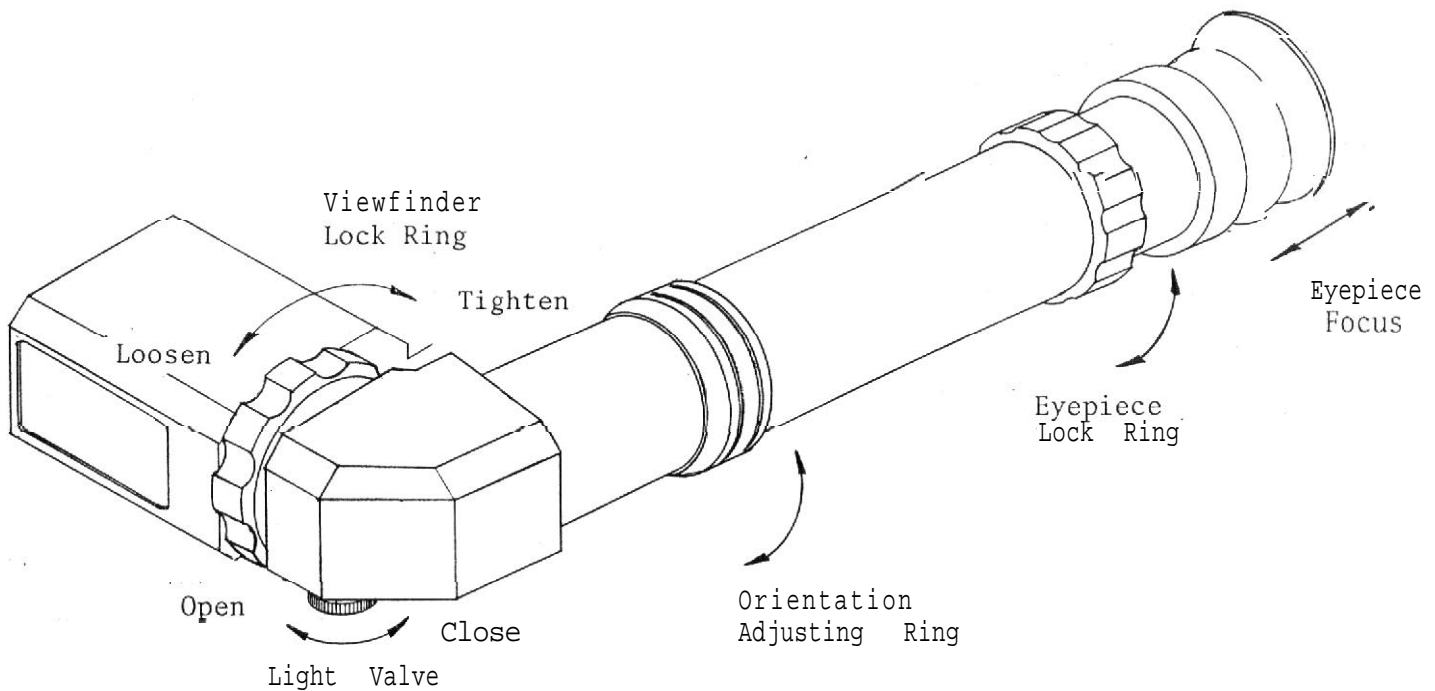

The eyepiece is adjusted by turning the eyepiece locking ring counterclockwise to loosen, sliding the eyepiece in and out to focus on ground-glass, and turning the locking ring back clockwise to tighten.

The light valve is opened or closed with a  $1/4$  turn of the light valve thumb wheel. This eliminates stray light returning through the viewfinder to the film when the viewfinder is not being used.

## FILM CLIP REGISTER PINS AND GROUNDGLASS

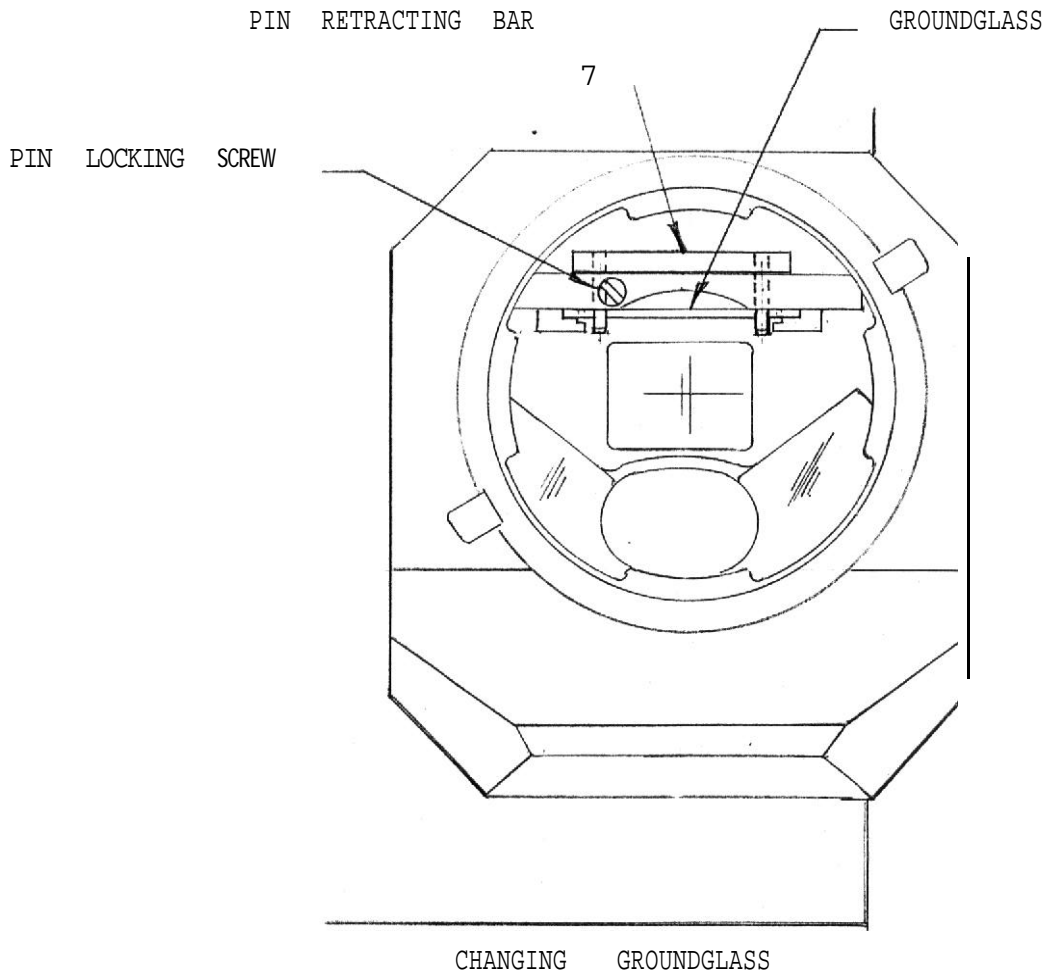

The groundglass is accessible through the lens port opening. To remove the groundglass first you must loosen the pin locking screw (approximately one turn) lift up on the pin retracting bar until the register pins are clear of the groundglass. Then remove by simply sliding the groundglass forward out through the lens port opening. To install a groundglass carefully slide it in between its two guide rails until it clears the register pin holes. Lower the register pins and tighten the pin locking screw, then pull the groundglass forward until the groundglass is located against the two register pins.

NOTE: The groundglass is installed with the ground surface facing down towards the rotating mirror.

## FILM CLIP

There is a film slot located on each of the groundglass guide rails. The slots will accommodate a full width 35mm film clip.

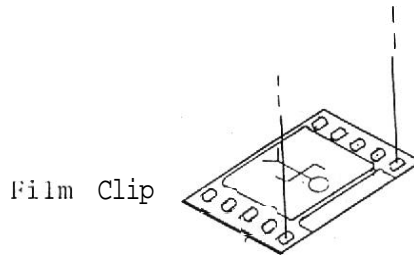

The film clip length can be cut with a regular pair of scissors. The tail should be cut on the frame line. When cutting the head end include one more set of perforations; those being the same ones used by the movement to register that frame. Hold the edge with the extra perforations and slide the film clip in from the front until the extra perforations are lined-up with the pins. Carefully push onto the pins.

## HIGH SPEED MOVEMENT

The high speed movement moves the film intermittently and holds it in position for the exposure of each successive frame. A pull-down claw draws the film into place behind the aperture, and registration pins on a horizontal shaft actuated by a cam hold the film stationary during exposure. A removable pressure plate, held in place by a retainer arm, holds the film flat at the aperture. The aperture plate is made of stainless steel, hard chrome plated, and has raised surfaces at the sides that hold the film along its edges: A matte slot in the aperture plate allows the insertion of mattes for multiple exposure work. A space of .015 inch in the film race is sufficient for two films or spliced film.



## SHUTTER

In the 35R3 the rotating mirror is a full speed design that acts as the shutter with a 170° opening, similar to the Arri III camera.

NOTE: Because of this shutter design, this reflex is not suited for single framing with long intervals between exposures.

## FOOTAGE COUNTER

A footage and frame counter is built into the rear of the camera box. The reset knob is located to the left of the counter. Some cameras have a dial counter that records the amount of film used from the magazine.

## MAGAZINES

Magazines may be obtained in 400-foot or 1000-foot capacities. Each magazine is corduroy and velvet lined. Two lids on the side of the magazine unscrew to permit loading or removal of the film. Both compartments of the magazine are light proof, and a spring-loaded ball at the center of each lid insures a snug fit and prevents rattling. The magazine throat or light trap consists of three velvet-covered rollers held in contact with even pressure by spring tension on the outer rollers. This keeps the magazine light-tight at all times and prevents film scratches as the film is drawn from the magazine. The loading compartment spindle has a keyway to fit standard film cores. In the 1000-foot magazine, the take-up spool is of the contractible type. The take-up spool in the 400-foot magazine may be used in this magazine if desired.

The magazine take-up spindle is turned by a belt and pulley connecting with the main drive shaft of the camera. Either a spring, plastic or leather belt may be used. The magazine is held in place on the camera by a toe plate at the front and by a hold-down screw at the rear.



MOTORS : The 120M3 is a DC-Servo controlled drive motor especially designed for the Fries 35R3 camera. The motor operates from a 30 VDC battery or power supply. The motor has eight switched frame rates from 12 FPS to 120 FPS. It is crystal controlled at 24 FPS or 25 FPS; runs both forward and in reverse. The motor has provisions for remote control functions such as TV interlock, single frame, variable speed control, and an intervalometer.

MOTOR CONTROLS: The R120M is a small hand-held control box for remote start-stop. Also contained in the remote box is the single-frame control. Continuous actuation runs the camera at 4 FPS cine speed. The single-frame exposure is 1/8 second at 170° shutter opening.

The RV120M is a continuously variable speed control in a small hand-held unit. Frame rates are infinitely variable from 4 to 120 FPS, and can be locked onto any selected speed. A built-in LED display is switchable to read speed in frames per second or film usage in feet. In the film usage mode, the display can be switched to read frames. Also contained in the variable speed unit is a single frame control with the same features as the RV120M above.

The 35R3 will still accommodate the standard Mitchell motor door and drive motors.

NOTE: The standard motors interfere with the Video Assist option.

VIDEO ASSIST : All 35R3 camera conversions are prepared for video assist. The video assist utilizes a 2/3 inch low-light newvicon black and white 12 VDC video camera. The video systems are available in both American and European standards. The standard Mitchell motors interfere with the video assist.

## SECTION II - Operation

### LOADING MAGAZINE

The magazine is loaded in either a dark **room** or a changing bag.

1. Unscrew magazine covers and turn velvet light trap rollers to make sure they are free. Before loading, clean inside of magazine with a brush or light air pressure.

2. Unpack the roll of unexposed film from its wrapping and unwind about two feet of film.

3. Lay the roll to the left of the magazine (by the front drum) with the film coming down from the right side. This is important as the emulsion is on the inner surface and this side **must face** the lens.

4. Push the film end down between the idler rollers and the center portion, then through the light trap rollers of the forward compartment.

NOTE: Threading the magazine can be accomplished more easily by first making a six-inch diagonal fold in the center of the film end and slanting to the edge.

5. Place film roll core in **position on** spindle and pull through all slack. The film **core** key fits a key-way on the magazine spindle.

### CHANGING MAGAZINE DRIVE BELT

Spring-type belts can be pushed through the magazine drive belt race without removing the drive. The ends of these belts are rotated in opposite directions, then screwed together to form a smooth joint. Leather belts can also be inserted in this way, but the belt must **be opened** before insertion. The plastic-type endless belts can be inserted only by removing the drive assembly from the camera. Remember that there are two sizes of magazine drive belts. Do not attempt to stretch the 400 foot belt over the 1000 foot magazine drive pulley.

SECTION 11

Threading the Camera:

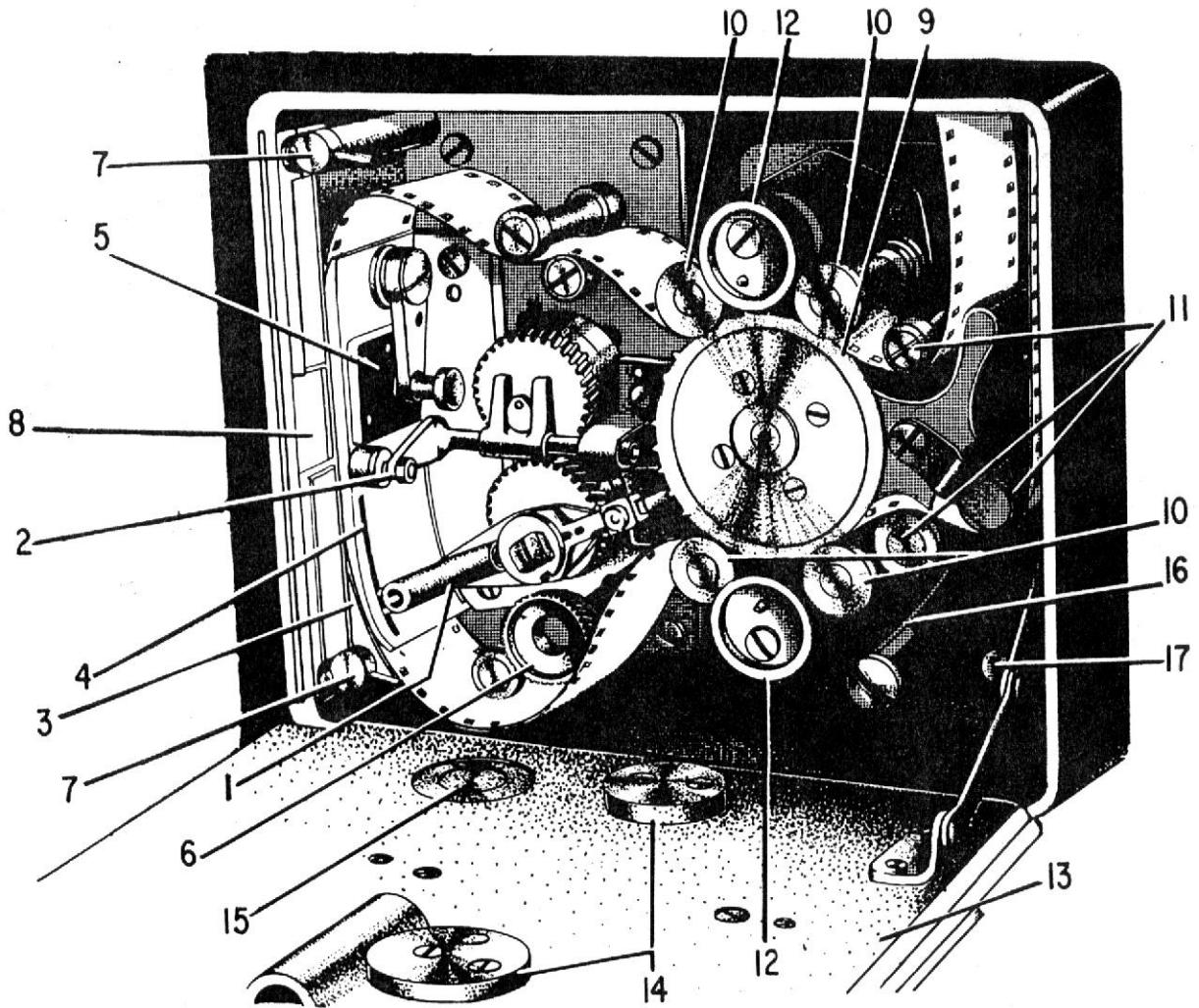

1. Pulldown claw
2. Pilot pin.
3. Aperture plate.
4. Register plate.
5. Pressure plate.
6. Pulldwon arm lock.
7. Aperature plate locks.
8. Aperture plate matte slot.

9. Sprocket.
10. Sprocket guide rollers.
11. Idler rollers.
12. Sprocket film gides.
13. Camera box door.
14. Sprocket guide registers.
15. Pulldown lock registers.
16. Buckle trip.
17. Buckle trip reset.

## THREADING THE CAMERA

Threading the camera is done without cutting the film. When preparing to use a cold camera, run the camera for several minutes before threading the film. This will allow the motor and mechanism to warm up to operating temperature, insuring a constant speed when the first scene is taken.

1. Withdraw register pins from aperture plate by aligning witness marks on top cam assembly.

2. Loosen pulldown arm lock screw (6), and pivot claw assembly (1) back as far as it will go to remove claw assembly from aperture; tighten pulldown arm lock screw to hold claw assembly in back position.

3. Remove and clean both the aperture (3) and pressure plates (5) as instructed in Section III. After cleaning, reinstall both plates. The plates must be cleaned each time the camera is threaded.

4. Release sprocket film guide keepers (12). Then extend film loop by pulling film from supply side of magazine. Thread camera as shown in diagram.

5. Loosen thumbscrew, allowing spring to push claw arm forward against film.

6. Pull film slowly upward and claw arm will drop into perforation; tighten thumbscrew. (Door cannot be closed unless thumbscrew is tight).

7. Make certain lower loop between movement and sprocket is adjusted correctly. Lower loop should clear bottom of camera box by  $1/8$  to  $1/4$  inch at lowest point of travel. If loop is too short, turn the threading knob on sprocket with film disengaged from sprocket and film guide.

CAUTION: Film loops must be adjusted accurately. Film must be taken out or taken up over the sprocket, not by moving the film in the race. Film breakage is usually caused by improper threading, particularly in the forming of loops. If a film **breaks**, the **camera must** be thoroughly cleaned and then rethreaded.

8. Adjust upper loop so that film has free entry into aperture plate and just clears the upper radius on aperture plate when loop is at its fullest. If loop is too short, draw necessary film from feed sprocket. Place film in position on top of sprocket and lock in place with upper sprocket film guide.

9. Turn camera slowly and observe movement of film at aperture and action of **pulldown** claw and registration pins. Make sure film does not tighten on idler rollers or touch box at any point.

10. Close camera box door. If upper or lower sprocket guides are not in place, the camera door will not close.

#### FILM BUCKLING

Film buckling is immediately apparent because the buckle trip switch will stop the camera. No attempt should be made to turn the camera by hand or serious damage may result. The occurrence of buckling will be indicated by the noise of the film crumpling inside the camera before the motor is stopped by the buckle trip switch. As soon as the motor stops proceed as follows:

1. Turn power OFF.

2. Remove belt from take-up pulley on magazine and take up the excess film in camera by turning the pulley by hand.

CAUTION: Do not allow the magazine belt to move the mechanism inside the camera while taking up the excess film. Operation of the camera movement at this time may cause serious damage. If the film is so tightly jammed that it cannot be taken up by rotating the pulley, it will be necessary to open the camera door and free the film before winding it up on the take-up spool.

3. Open the camera door and remove the aperture and pressure plates. Examine the film aperture to be sure that no pieces of torn film are

obstructing the light passage. Examine the registration pins and pulldown claw to make certain they have not been bent. Examine the slots and holes in the aperture plate to make sure that punched pieces of film have not lodged there. Make certain all torn pieces of film are removed from the camera.

4. Rethread camera and reset buckle trip by pulling out knurled reset knob.

5. Run a short length of film through the camera, then remove and examine it carefully under a magnifying glass to see that no scratches are present on emulsion and perforations are undamaged.

#### CHANGING LENS MOUNTS

Interchangeable lensmounts are available for Nikon, Arri P1, and BNCR mounted lenses. All lensmounts are interchangeable and can be ordered on standard Academy centerline or on full-frame silent centerline for those shooting background plates, etc.

The lensmounts are attached to the camera body with four screws, as shown on the sketch below.

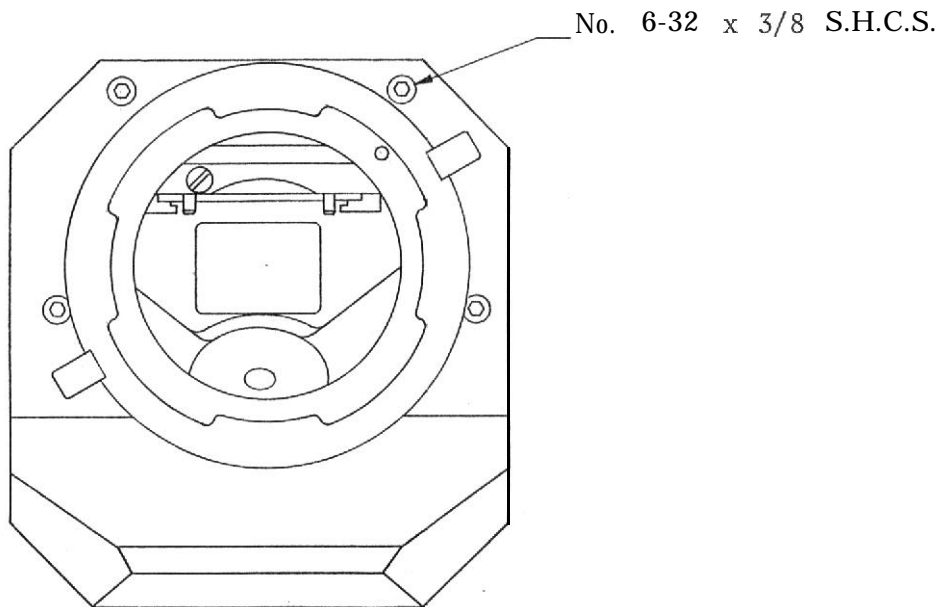



## GROUNDGLASSES

The groundglass is readily interchangeable and available for all standard formats including: 1.85/TV, 1.33/TV, 1.85/1.33, 1.66, 2.35, etc.. Specials can be made to customer requirements.

## FILM CLIP

A special feature of the 35R3 is the ability to insert a film clip in the viewfinder. The clip is positioned on a set of precision aligned register pins, and therefore, needs no special punch. The clips is viewed simultaneously by the operator and the optional video assist.

## FOOTAGE COUNTER

The dial counter should be reset to zero whenever a new magazine is installed on the camera. A knob at the **center** turns the pointer. The frame and footage counter can be used to record the footage of film used for an individual scene. The reset handle is directly to the left of the counter windows. The last window on the right of the footage counter registers individual frames and is marked in increments from one to sixteen. (There are sixteen frames per foot of film). The frame counter does not reset to zero with the footage counter.

## MATTE BOX

The 35R3 baseplate is designed to mount on any gear or friction head as well as directly onto an Arriflex sliding balance plate to allow the use of all appropriate Arri accessories such as matte boxes, follow focus, etc..

VIDEO ASSIST

Installation:

First, remove the viewfinder assembly. This is accomplished by removing the three allen cap screws, and carefully lifting the housing up and forward.

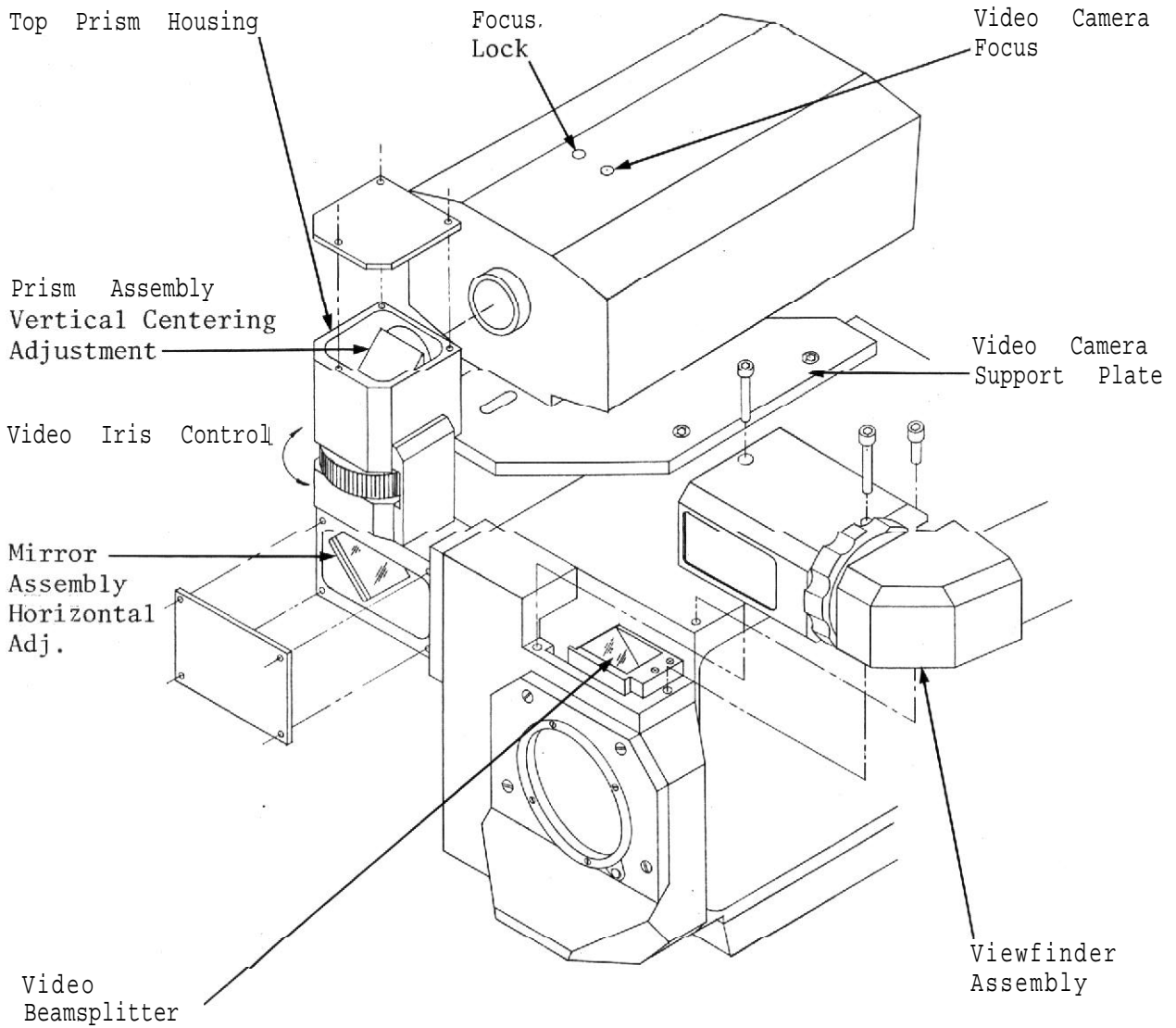

Then install the video beamsplitter assembly with its two mounting screws as shown. Remove the video cover plate, and install the optical housing assembly to the motor side of the camera as shown above.

Screw the video camera support plate to the top of the 35R3 camera body as shown. Mount the video camera to its support plate and align front with the optical housing port.

Reinstall camera optical block and viewfinder assembly.

#### Alignment Procedures:

NOTE: All alignment and focus procedures are easier to accomplish with the film camera prime lens removed or pointed at a blank white card, allowing the video system to see the groundglass reticle only.

Optical alignment involves the centering of the groundglass image on the faceplate of the video tube by adjusting (repositioning) a mirror and a prism in the optical path.

To reposition the image vertically, remove the three screws and cover on the top prism housing and loosen the two inside screws that lock down the prism assembly. Slide the prism assembly forward or backward until the image is centered, lock down the two screws and replace the cover plate.

To reposition the image horizontally, remove the four screws and cover plate of the lower mirror housing. Loosen the two inside screws, tilt the mirror to achieve horizontal center, and lock the two screws down on the mirror bracket. Replace the cover plate.

Electronic centering can also be used to correct the image. Inside the video camera are trim pots labeled: "VC", vertical centering, and "HC" horizontal centering. Normally these controls are preset to approximately their middle range, and all corrections are made mechanically as previously described. This assures your image of being in the center of the faceplate of the tube. If necessary, these controls can be used to make minor adjustments.

Section 111

Cleaning Camera Box:

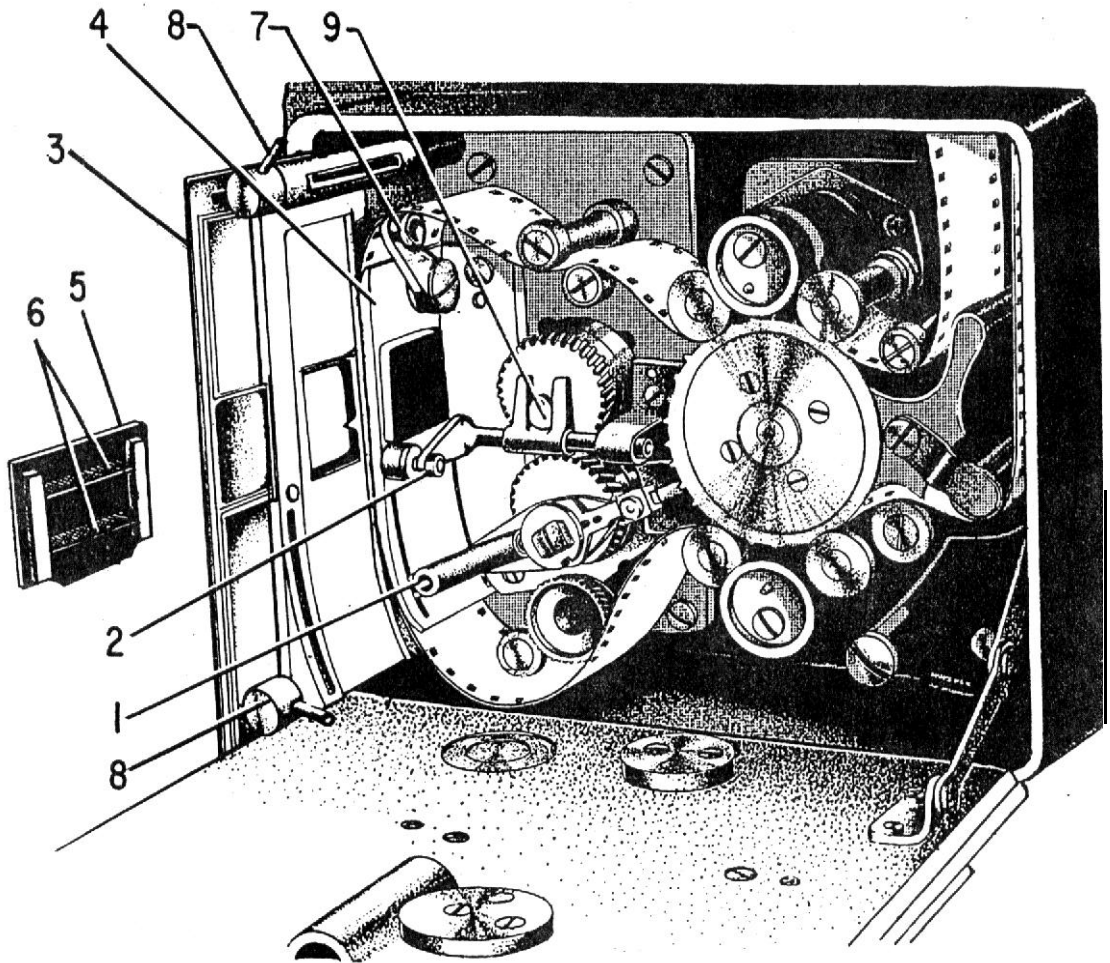

1. Pulldown arm.
2. Pilot pin.
3. Aperture plate.
4. Register plate.
5. Pressure plate.

6. Pressure plate rollers.
7. Pressure plate retaining arm.
8. Aperture plate locks.
9. Movement cam.

## SECTION III - Maintenance

### CLEANING CAMERA BOX

The interior of the camera must be cleaned after each period of use. The cleaning is usually done with an air syringe to blow off loose dust, a camel's hair brush to dislodge clinging foreign material, and a lintless cloth for wiping polished surfaces. To clean the camera box interior, proceed as follows:

1. Open the camera door and remove the aperture plate and pressure plate.
2. Vacuum all loose dust from the mechanism and from the corners of the camera box.
3. Use camel's hair brush to get into corners and around the sprocket and guide rollers. Make sure all bits of emulsion or film are removed.
4. Wipe the polished metal surfaces carefully with soft, lintless cloth.
5. With the camel's hair brush, remove from the mechanism and interior of the box any threads or foreign material that may have been loosened by the cloth.

NOTE: When camera is run without film or pressure plate--excess oil from movement may be slung onto the rotary mirror and lens rear element.

### CLEANING THE MIRROR

The mirror is fragile and should be cleaned and handled only when necessary, and with extreme care.

1. For dust or light dirt specs try using a clean, soft camel hair brush; brushing the mirror surface lightly.
2. After brushing, if there are still a few small specs or oil spots, try using standard lens cleaner and lens tissue. Do not apply any pressure to the mirror surface.

PRECAUTIONARY NOTE: If mirror is not wiped dry, but allowed to dry in air, a stain may result which will permanently damage the coating.

## CLEANING PRESSURE PLATE

The pressure plate must be inspected and cleaned each time the aperture plate is cleaned.

1. Remove pressure plate from camera by swinging retainer arm upward and lifting plate out.
2. Remove all loose dust and bits of emulsion with a camel's hair brush.
3. Wipe the forward side of the plate with the ball of the thumb to remove all loose dust and bits of emulsion.
4. Test the rollers to see that they revolve freely. If they show a tendency to stick, immerse the pressure plate in cleaning solvent, revolving the rollers while they are in the fluid. Dry the plate thoroughly with a clean, lintless cloth; then use an air syringe to evaporate the solvent that may be adhering to the roller bearing pins. When the plate is dry, apply a small amount of camera oil to the roller with a toothpick. Be sure to wipe off all excess oil.

## CLEANING APERTURE PLATE

Clean aperture plate at least every 1000 feet or each time the camera is threaded,

1. Turn camera to threading position.
2. Pass a piece of film between the register plate and aperture plate to ascertain that registration pins and claw are fully retracted from aperture plate.

CAUTION: Failure to check this may result in damage to the aperture plate.

3. Turn the two aperture plate locks until the pins point upward, then carefully slide aperture plate straight out of camera.
  4. Inspect for bits of emulsion on aperture plate. Clean aperture and film race with a camel's hair brush.
- CAUTION: Never use abrasive cleaners.

5. Remove accumulated emulsion from the film race, the registration pin holes,

and the pulldown claw travel slots using an orange stick or any **other** type of pointed, **soft** wooden prod.

6. Blow through the registration pin holes and the claw slots with an air syringe.

7. Polish the film race with the heel of the hand. Place a drop of Mitchell Camera Oil on the film race and rub it in thoroughly with the thumb or heel of the hand to remove all excess oil. The hand must be free of grit and perspiration. Be sure the registration pin holes and claw slots are dried completely.

#### CLEANING FILM MOVEMENT

The movement must be kept clean at all times. If salt water, sand, or any other foreign material enters the movement, it should be thoroughly cleaned as follows:

1. Remove and clean aperture and pressure plates.

2. Remove the flywheel from the movement shaft. The flywheel is held on to the shaft with a retaining screw and lock screw key.

3. Remove the three screws which hold the movement to the camera box and withdraw the movement. Be careful of exposed registration pins when aperture plate is removed.

4. Immerse the movement parts in solvent and clean them with a soft brush. Remove all oil and grease.

5. Blow all parts dry with air or wip them dry if air is not available.

6. Lubricate the movement by oiling or greasing all points shown on lubrication chart. Force grease into the ball-bearing races. Force three drops of oil into pulldown arm ball-bearing.

7. Reinstall aperture and pressure plates.

8. Time movement as in following paragraph when replacing it in camera.

Whenever movement is removed from camera box it must be retimed with the shutter.

SECTION III - Timing the Movement

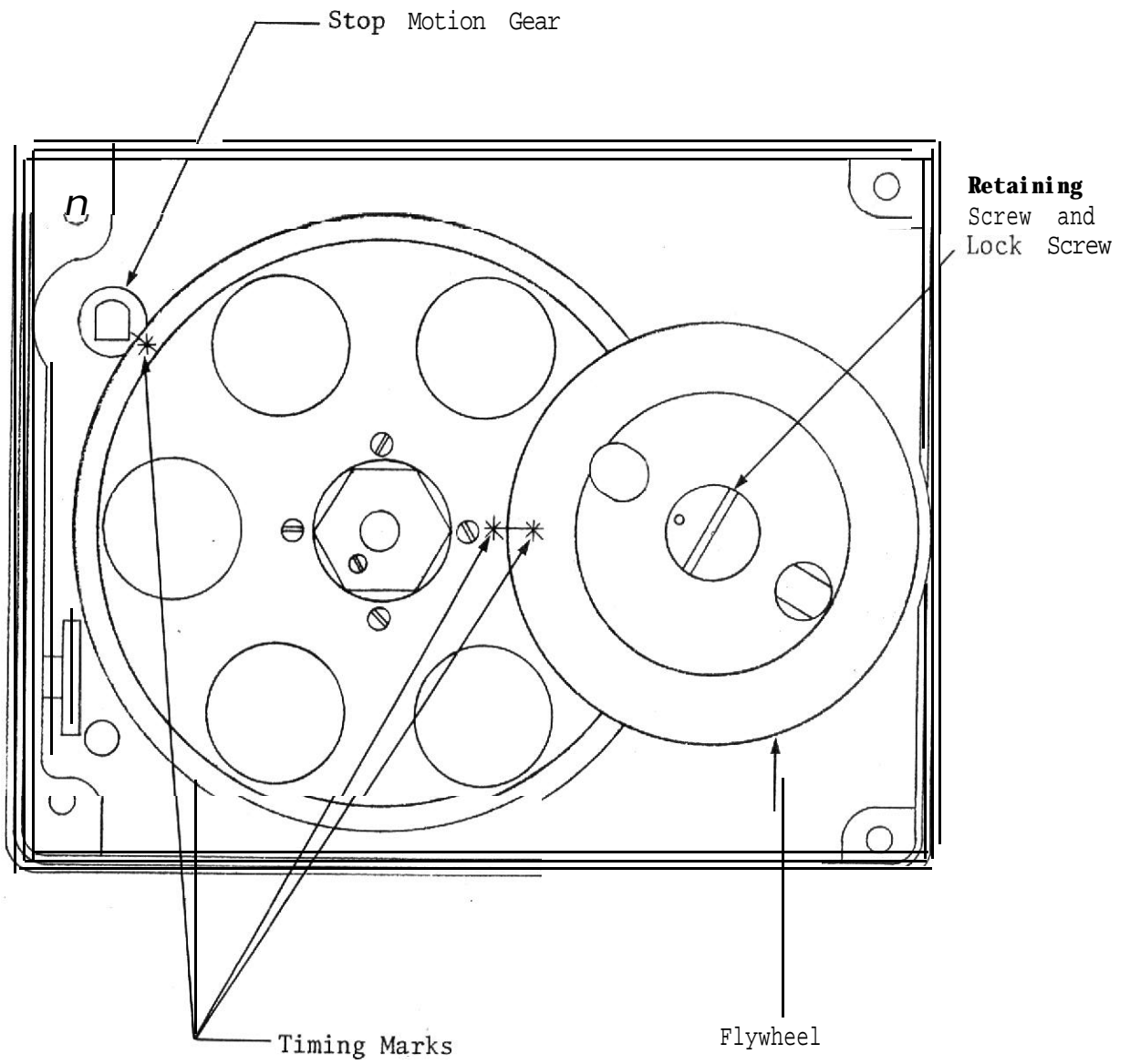



Do not attempt to operate camera if movement and shutter have not been placed in proper synchronization.

#### TIMING THE MOVEMENT

The camera movement must be timed whenever it is taken out of the camera. The timing operation consists of synchronizing the movement and shutter so that the shutter is closed whenever the film is in motion and open when the film is registered, and motionless in front of the aperture. Thus, when the pulldown claw is engaging or leaving the film sprocket holes, the shutter must be closed.

1. Insert movement in camera box and secure it with the three screws provided.
2. Turn the large brass gear in the right side of the camera box until the punch mark on this large gear is opposite the scribe mark on the stop motion gear.
3. Slide the flywheel into position so the index mark on the rim of the flywheel is slightly above the index mark on a spoke of the large brass gear.
4. As the flywheel gear is pushed into mesh with the large gear, it will rotate counterclockwise. This should bring the index marks together, and at the same time the rounded portion of the stop motion shaft should be at the top.
5. Replace the flywheel retaining screw and lock screw.
6. Place a small amount of grease on all gear teeth.

#### CHECKING TIMING

1. Remove the taking lens from front of camera.
2. Set the shutter lever at  $170^{\circ}$ .
3. Insert a strip of film in the film race.
4. Turn the movement slowly, causing the arrow on the cam to turn clockwise until the registration pins touch the film. At this point the shutter should be just starting to open. (About  $1/8$  inch of the shutter opening will be visible in

the lower left-hand corner of the aperture).

5. Turn the movement so the cam arrow rotates counterclockwise until the registration pins touch the film. At this point the shutter should be closed except for about 1/8 inch of opening in the upper right-hand corner of the aperture.

#### LUBRICATION

Use Mitchell Camera Oil for all lubrication points requiring oil. The lube points shown in the movement sketch should be lubed after every 1000 feet of film; especially when running at high speed. All other idler rollers, sprocket guide rollers and keepers need only to be lubricated after every 50,000 feet of film.

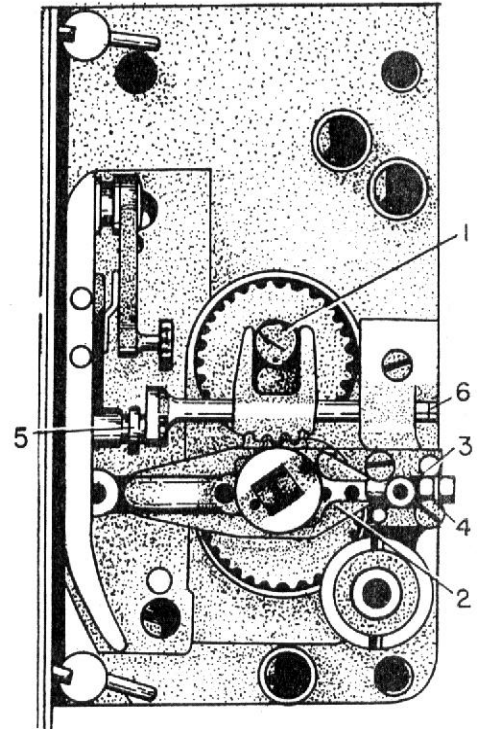

1. Movement cam.
2. Pulldown arm oil hole.
3. Pulldown arm rear support.
4. Pulldown arm shaft.
5. Pilot pin front guides  
(2 lube points).
6. Pilot pin rear guide.

## LENSES

Interchangeable lensmounts are available for Nikon, Arri PI, and BNCR mounted lenses. All lensmounts are interchangeable and can be ordered on standard Academy centerline or on full-frame silent centerline for those shooting background plate, etc.

## CAMERA DIMENSIONS AND MOUNTING

All cameras are refinished in standard black wrinkle. Weight: 18 pounds - no lens or magazine.

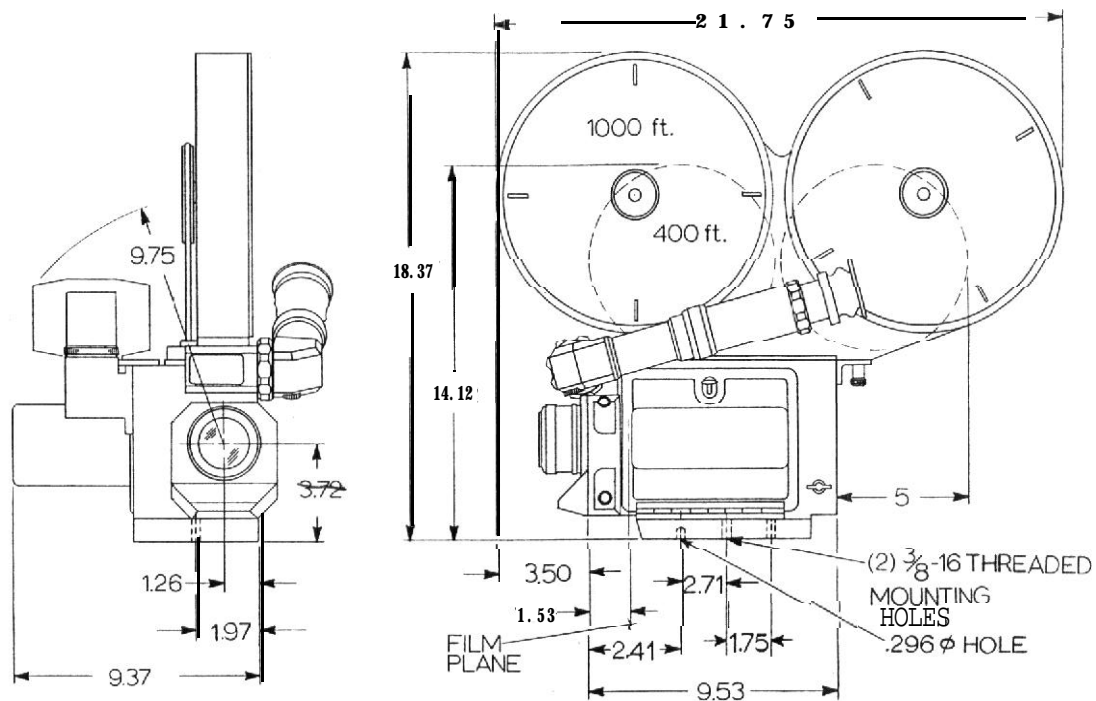

## CAMERA ACCESSORIES

MAGAZINES : Standard GC 400 and 1000 foot Mitchell Magazines.

MATTE BOXES : Rod holders are available for both the GC lower matte box, and  
BNC Side Swingaway Mitchell matte box.

FOLLOW FOCUS: A follow focus assembly is available for the BNCR lenses.