

3 5 R

OPERATION AND SERVICE MANUAL

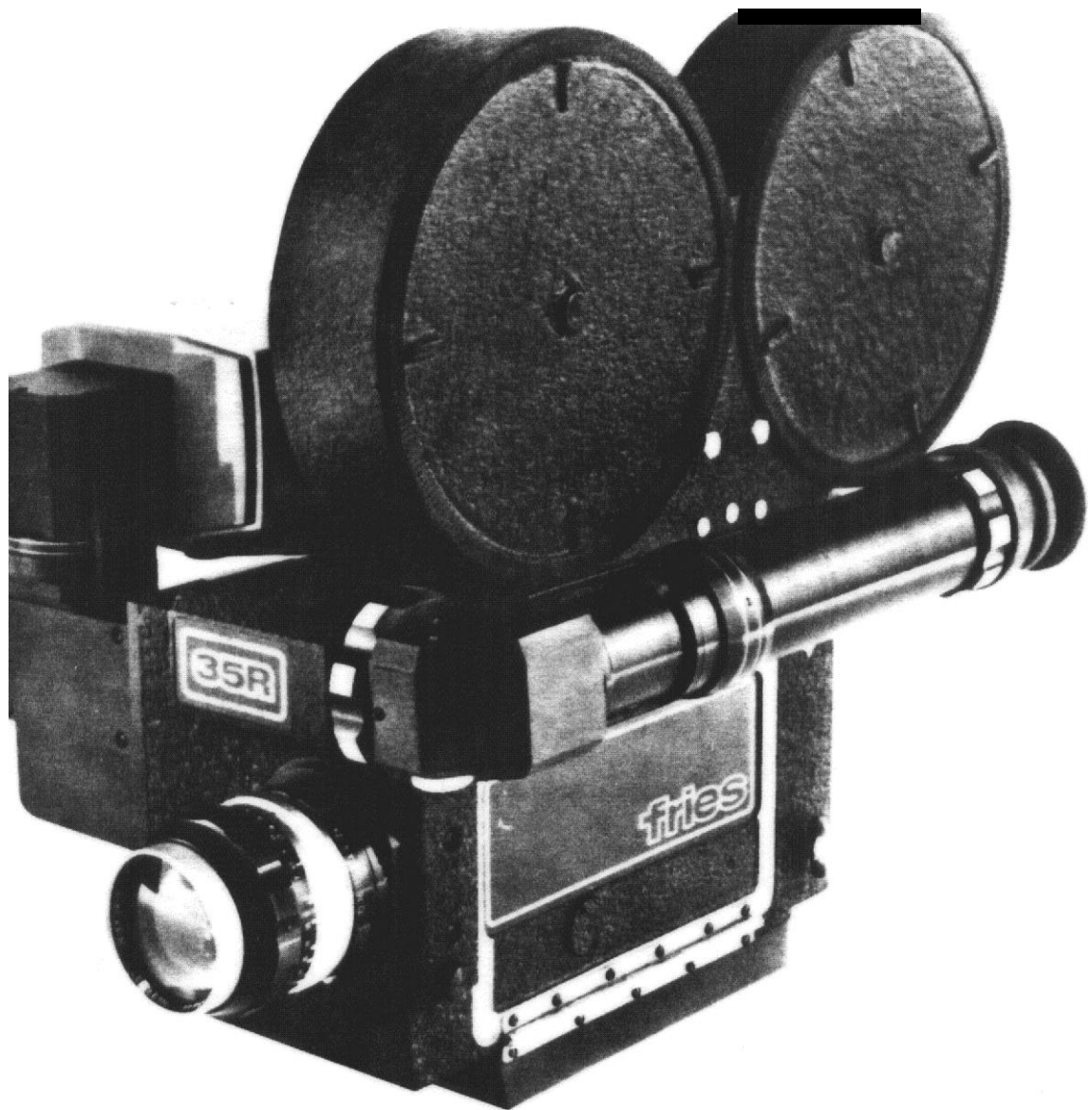

FRIES 35R BEAMSPLITTER REFLEX CONVERSION TO MITCHELL GC HIGH SPEED
35MM MOTION PICTURE CAMERA

fries
Engineering inc.

Fries Engineering, Inc. 8743 Shirley Avenue Northridge, California 91324 818-998-5400 FAX 818-998-7553

PRICE 10.00

CONTENTS

SECTION 1	<u>DESCRIPTION</u>	
	General	4
	Camera Box	4
	Orientable Viewfinder	5
	Optical Block	6
	High Speed Movement	7
	Shutter	8
	Footage Counter	8
	Magazines	8
	Lenses	Q
	Dimensions.....	10
	Accessories.....	10
SECTION 11	<u>OPERATION</u>	
	Loading Magazines.....1	3
	Changing Magazine Drive Belt.....1	3
	Threading The Camera.....1	4
	Film Buckling.....1	6
	Changing Lensmounts.....	17
	Groundglasses.....	19
	Film Clip.....	19
	Filter Holder.....	19
	Shutter Adjustment.....2	0
	Footage Counter.....2	0
	Matte Box.....2	0
	Video Assist.....2	1

CONTENTS

SECTION 111

MAINTENANCE

Cleaning Camera Box.....	.24
Cleaning Beamsplitter...	.24
Cleaning Pressure Plate.....	.26
Cleaning Aperature Plate.....	.27
Cleaning Film Movement..	.28
Timing The Movement.....	.28
Lubrication.....	31

SECTION 1 - Description

GENERAL DESCRIPTION

The Fries 35R is a reflex conversion to the Mitchell Standard/High Speed camera. The Mitchell was chosen for its world famous steadiness, reliability, and high speed capabilities. To meet the various requirements of modern day special effects and commercial productions, a modular design has been incorporated. This allows the cameraman the freedom of choice of lenses, lens centering, motors, video assists, etc., and at the same time the conveniences of a modern reflex camera.

CAMERA BOX

The camera box is divided longitudinally into two compartments. The left-hand, or operating side contains the film moving mechanism and the intermittent movement. The right-hand side contains the camera driving mechanism. The operating side has a door hinged at the bottom. On top of the camera is a recessed plate for attaching the film magazine and an opening through which the film is drawn from the magazine to the film compartment of the camera. A dust plate is provided to cover this opening when a magazine is not in place. The magazine drive assembly is located on top of the camera box.

Film is drawn from the magazine and fed to the movement by a sprocket with 32 teeth. The film is held against the sprocket by two sprocket guide assemblies. A buckle trip is provided to stop the camera immediately in case of film take-up failure. The buckle trip lever actuates a film buckle switch in the camera motor door, cutting off the power.

ORIENTABLE VIEWFINDER

The entire viewfinder can be adjusted through 360° of rotation.

To adjust: Loosen the viewfinder locking ring by turning counterclockwise (it should not be necessary to loosen by more than $1/4$ of a turn), position viewfinder, and tighten locking ring by turning clockwise.

NOTE: The viewfinder rotation locking ring should never be tightened **more** than "finger tight".

The image must be reoriented with every new viewfinder position. To adjust, rotate orientation adjusting ring until image is horizontal.

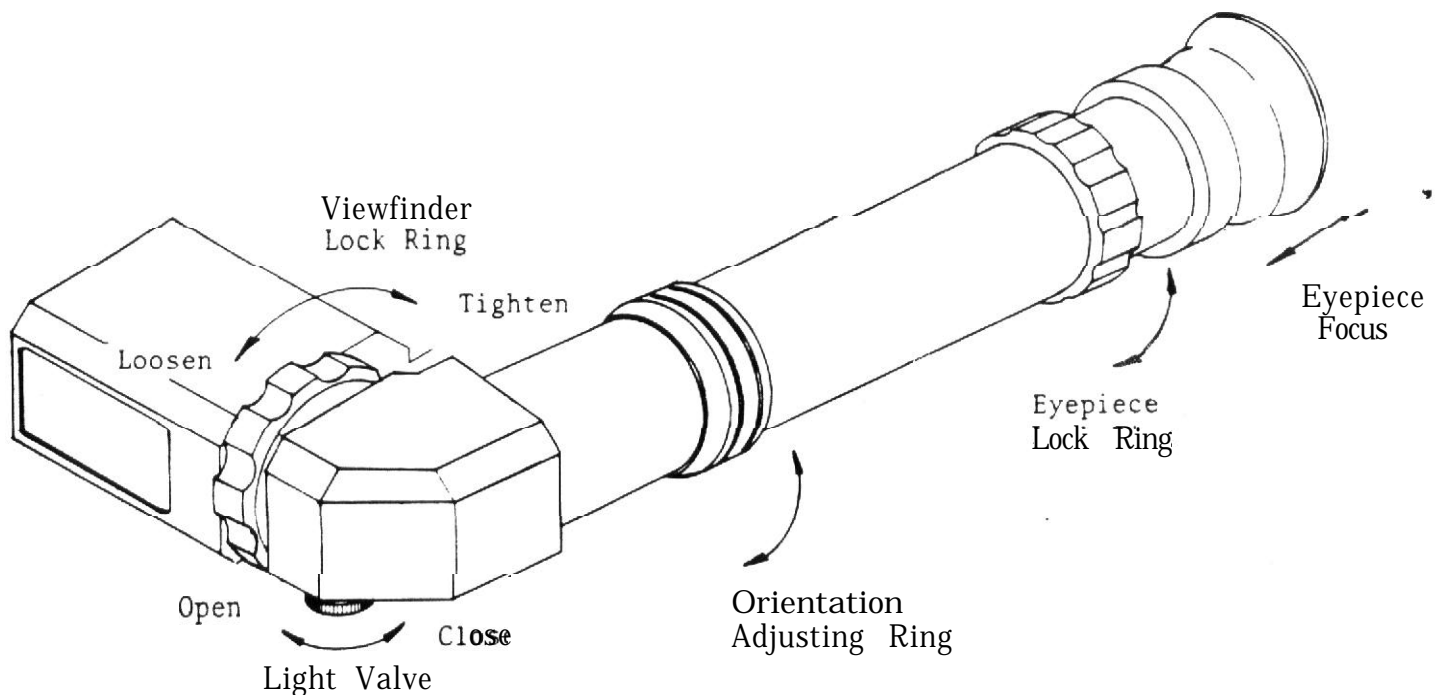

The eyepiece is adjusted by turning the eyepiece locking ring counterclockwise to loosen, sliding the eyepiece in and out to focus on **ground-glass**, and turning the locking ring back clockwise to tighten.

The light valve is opened or closed with a $1/4$ turn of the light valve **thumb** wheel. This eliminates stray light returning through the viewfinder to the film when the viewfinder is not being used.

OPTICAL BLOCK

The optical block is the heart of the 35R conversion of the Mitchell GC-Std. Its external cover plate is located under the viewfinder adjustment mechanism and is held in place with two captive screws. To remove the optical block, loosen the captive screws and slide the optical block out horizontally, holding it by the cover plate. Care must be taken to keep glass parts free of fingerprints.

The optical block contains the reflex beamsplitter, interchangeable groundglass, field lens, and special holders for both gelatin filters and film clips.

The primary beamsplitter is most sensitive to contamination. The front surface has a partial vacuum deposit. The back surface has a high

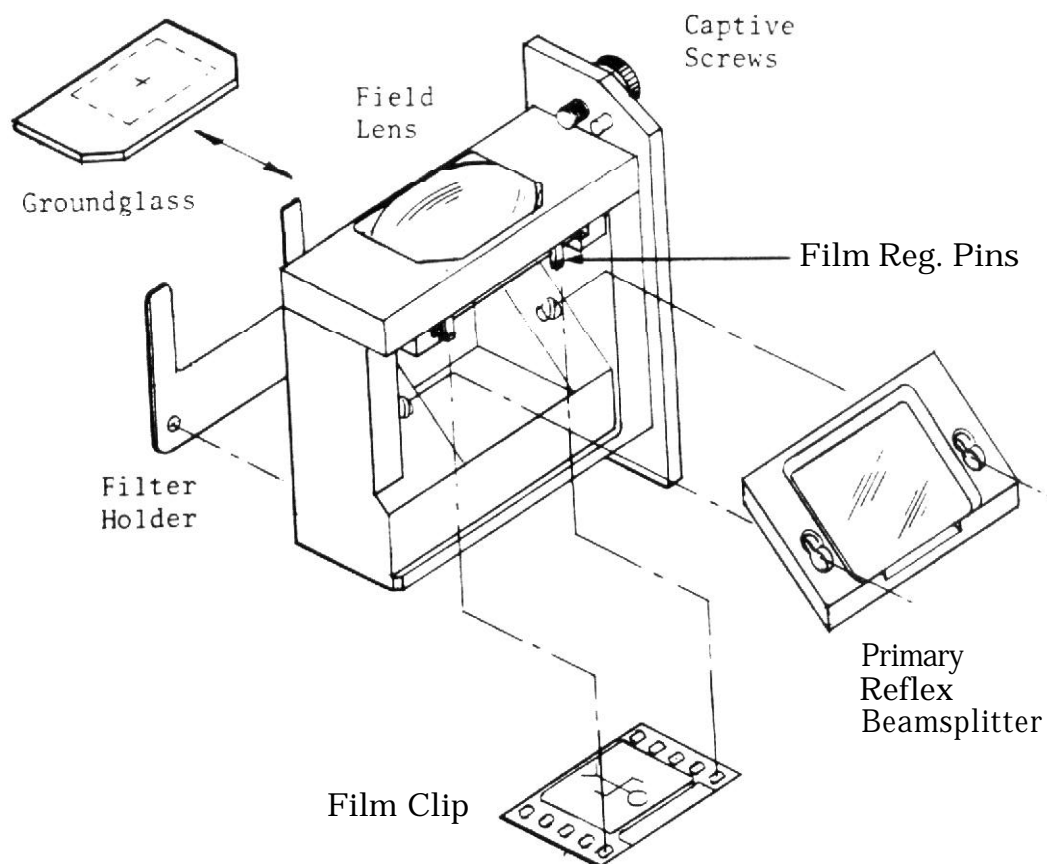

efficiency anti-reflection coating. Both surfaces **must** be handled **with extreme care**. To replace, loosen, but do not completely remove the two screws located on the beamsplitter holder; push the beamsplitter holder upward until **the** two screwheads are located above their expanded slot ends, and pull out. A new beamsplitter and holder may be installed in the reverse order. Make sure that **there** is no dirt or particles under the holder as this may affect the focus and line-up.

The groundglass is located just under **the** field lens. It is held in place horizontally between two guide rails and against two precision aligned film registration pins. It is removed by simply sliding out from back -- installed with grind **on** bottom.

With **the** groundglass in place, a narrow slot is formed on each gib to accommodate the insertion of a film clip. A film clip may be cut with regular scissors being careful to include one more set of perforations; those being the same ones used by the **movement** to register that frame. Hold the edge with the extra perforations and slide the film clip in from **the** front until the extra perforations are lined-up with the pins. Carefully push onto the pins.

The filter clip is located behind **the** beamsplitter and will accommodate a 1" x 2" gelatin filter (obtained by cutting a standard 2" x 2" filter in half).

HIGH SPEED MOVEMENT

The high speed movement moves the film intermittently and holds it in position for **the exposure** of **each** successive frame. A pull-down claw draws the film into place behind **the** aperture, and registration pins on a horizontal shaft actuated by a cam hold the film stationary during exposure. A removable pressure plate, held in place by a retainer arm,

holds the film flat at the aperture. The aperture plate is made of stainless steel, hard chrome plated, and has raised surfaces at the sides that hold the film along its edges. A matte slot in the aperture plate allows the insertion of mattes for multiple exposure work. A space of .015 inch in the film race is sufficient for two films or spliced film.

SHUTTER

The rotary dissolving shutter is designed for hand-operated dissolves and fades. It has a maximum opening of 170° , calibrated in increments of 10° , and can be closed down to any smaller opening at any rate of speed or locked and operated in any desired position. The shutter opening scale and adjusting lever are mounted on the rear of the camera. The shutter is synchronized with the movement so that when its open segment is in front of the aperture the film is at rest. The film moves while the closed segment of the shutter covers the aperture.

FOOTAGE COUNTER

A footage and frame counter is built into the rear of the camera box. The reset knob is located to the left of the counter. Some cameras have a dial counter that records the amount of film used from the magazine.

MAGAZINES

Magazines may be obtained in 400-foot or 1000-foot capacities. Each magazine is corduroy and velvet lined. Two lids on the side of the magazine unscrew to permit loading or removal of the film. Both compartments of the magazine are light proof, and a spring-loaded ball at the center of each lid insures a snug fit and prevents rattling. The magazine throat or light trap consists of three velvet-covered rollers held in contact with

even pressure by spring tension on the outer rollers. This keeps the magazine light-tight at all times and prevents film scratches as the film is drawn from the magazine. The loading compartment spindle has a keyway to fit standard film cores. In the 1000-foot magazine, the take-up spool is of the contractible type. The take-up spool in the 400-foot magazine may be used in this magazine if desired.

The magazine take-up spindle is turned by a belt and pulley connecting with the main drive shaft of the camera. Either a spring, plastic or leather belt may be used. The magazine is held in place on the camera by a toe plate at the front and by a hold-down screw at the rear.

LENSES

Interchangeable lensmounts are available for Nikon, Canon, Olympus, Contax (ZEISS), and BNCR mounted lenses. All lensmounts are interchangeable and can be ordered on standard Academy centerline or on full-frame silent centerline for those shooting background plate, etc. However, due to the special nature of the Canon lensmount, it cannot be added later, but must be ordered at the time of the initial reflex conversion. A follow focus unit is available for use with the BNCR mounted lenses.

The following is a list of lenses compatible with the 35R:

Nikon, Canon, Olympus, Contax/Yashica: all lenses

BNCR/Mitchell/Mobil Optics High Speed: all lenses

BNCR/Bausch & Lomb Super Baltar: all lenses - **caution**,
some 50mm F2 lenses may require slight rework.

BNCR/Cinema Products/Canon Ultra Fast: all lenses except
the 18mm T2.8

BNCR/Kowa Cine Prominar: 100mm T2.3, 75mm T2.3 & 50mm T2.3
are compatible. 40mm T2.3 & 25mm T2.3 prevent re-
moval of the optical block while the lens is in-
stalled. 32mm T2.3 - **caution**, some lenses may re-
quire slight rework. 20mm T2.3 & 15mm T4 will not
fit.

The R120M is a small hand-held control box for remote **start-stop**. Also contained in the remote box is the single-frame **control**. Continuous actuation runs the **camera** at 4 FPS cine speed. The single-frame exposure is 1/8 second at 170° shutter opening.

The RV120M is a continuously variable speed control in a small hand-held unit. Frame rates are infinitely variable from 4 to 120 FPS, and can be locked onto any selected speed. A built-in LED display is switchable to read speed in frames per second or film usage in feet. In the film usage mode, the display can be switched to read frames. Also contained in the variable speed unit is a single frame control with the same features as the R120M above.

The 35R will still accommodate the standard Mitchell motor door and drive motors. NOTE: The standard motors interfere with the Video Assist option.

VIDEO ASSIST: All 35R camera conversions are prepared for video assist.

The video assist utilizes a 2/3-inch low-light newvicon black and white 12 VDC video camera. The video systems are available in both American and European standards. The standard Mitchell motors interfere with the video assist.

AUTO-FOCUS 35R: **AF35R** was designed for computer-controlled or “motion control” camera tracking systems. The unit is basically a 35R beamsplitter reflex conversion to the Mitchell with the addition of a sliding base plate and bellows that allow the film plane, rather than the lens, to be adjusted for focus. A stepper motor drives a lead screw with a linear travel of **.200 in./revolution**.

The base uses Microslides crossed roller ways **for** minimum

friction with any load throughout the full 4-3/4 inch of travel. An optional internal capping shutter is available in addition to the camera's variable shutter that, under computer control, allows random frame access and ramping up to the speed before exposure. Other features include a stepper motor camera drive, motorized camera shutter control, and magazine torque motor take-ups.

SECTION II - Operation

LOADING MAGAZINE

The magazine is loaded in either a dark room or a changing bag.

1. Unscrew magazine covers and turn velvet light trap rollers to make sure they are free. Before loading, clean inside of magazine with a brush or light air pressure.

2. Unpack the roll of unexposed film from its wrapping and unwind about two feet of film.

3. Lay the roll to the left of the magazine (by the front drum) with the film coming down from the right side. This is important as the emulsion is on the inner surface and this side must face the lens.

4. Push the film end down between the idler rollers and the center portion, then through the light trap rollers of the forward compartment.

NOTE: Threading the magazine can be accomplished more easily by first making a six-inch diagonal fold in the center of the film end and slanting to the edge.

5. Place film roll core in position on spindle and pull through all slack. The film core key fits a keyway on the magazine spindle.

CHANGING MAGAZINE DRIVE BELT

Spring-type belts can be pushed through the magazine drive belt race without removing the drive. The ends of these belts are rotated in opposite directions, then screwed together to form a smooth joint. Leather belts can also be inserted in this way, but the belt must be opened before insertion. The plastic-type endless belts can be inserted only by removing the drive assembly from the camera. Remember that there are two sizes of magazine drive belts. Do not attempt to stretch the 400 foot belt over the 1000 foot magazine drive pulley.

THREADING THE CAMERA

Threading the camera is done without cutting the film. When preparing to use a cold camera, **run** the camera for several minutes before threading the film. This will allow the motor and mechanism to warm up to operating temperature, insuring a constant speed when the first scene is taken.

1. Withdraw register pins from aperture plate by aligning witness marks on top cam assembly.
2. Loosen **pull**down arm lock screw (6), and pivot claw assembly (1) back as far as it will go to remove claw assembly from aperture; tighten **pull**down arm lock screw to hold claw assembly in back position.
3. Remove and clean both the aperture (3) and pressure plates (5) as instructed in Section III, After cleaning, reinstall both plates. The plates must be cleaned each time the camera is threaded.
4. Release sprocket film guide keepers (12). Then extend film **loop** by pulling film from supply side of magazine. Thread camera as shown in diagram.
5. Loosen thumbscrew, allowing spring to push claw arm forward against film.
6. **Pull** film slowly upward and claw arm will drop into perforation; tighten thumbscrew. (Door cannot be closed unless thumbscrew is tight).
7. Make certain lower loop between movement and sprocket is adjusted correctly. Lower loop should clear bottom of camera box by $1/8$ to $1/4$ inch at lowest point of travel. If loop is too **short**, turn the threading knob on sprocket with film disengaged from sprocket and film guide.

CAUTION: Film loops must be adjusted accurately. Film must be **taken out or taken up over** the sprocket, not by moving the film in **the race**. **Film** breakage is usually caused by improper threading, particularly in **the forming** of loops. If a film breaks, the camera must be thoroughly cleaned and then rethreaded.

SECTION 11

Threading the Camera:

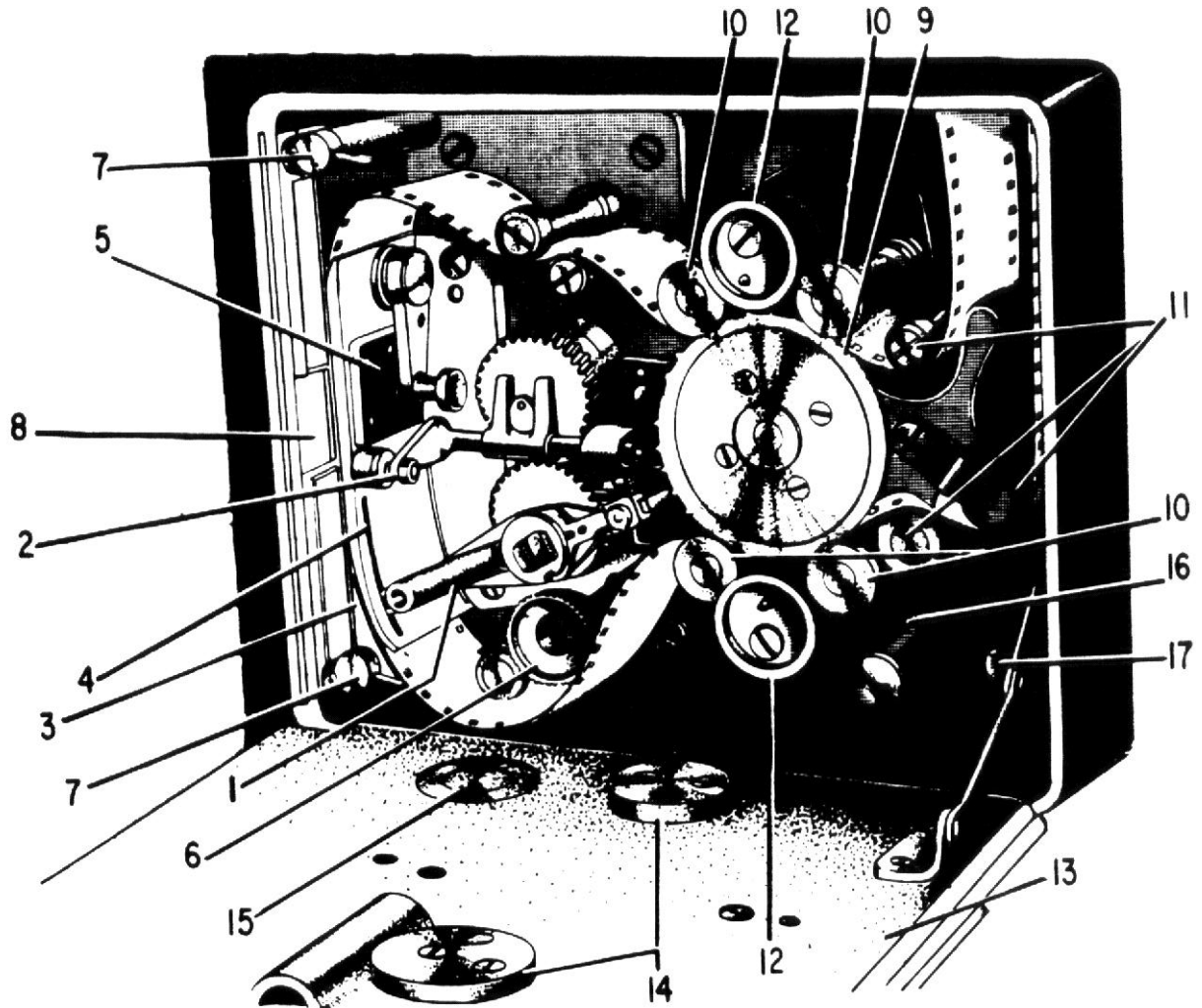

- | | |
|-------------------------------|-------------------------------|
| 1. Pulldown claw | 9. Sprocket. |
| 2. Pilot pin. | 10. Sprocket guide rollers. |
| 3. Aperture plate. | 11. Idler rollers. |
| 4. Register plate. | 12. Sprocket film guides. |
| 5. Pressure plate. | 13. Camera box door. |
| 6. Pulldown arm lock. | 14. Sprocket guide registers. |
| 7. Aperture plate locks | 15. Pulldown lock registers. |
| 8. Aperture plate matte slot. | 16. Buckle trip. |
| | 17. Buckle trip reset. |

8. Adjust upper loop so that film has free entry into aperture plate **and** just clears the upper radius on aperture plate when loop is at its fullest. If loop is too **short**, **draw** necessary film from feed sprocket. Place film in position on top of sprocket and lock in place with upper sprocket film guide.

9. Turn camera slowly and observe movement of film at aperture and action of **pull-down** claw and registration pins. Make sure film does not tighten on idler rollers or touch box at any point.

10. Close **camera** box door. If upper or lower sprocket guides are not in place, the camera door will **not close**.

FILM BUCKLING

Film buckling is immediately apparent because the buckle trip switch will stop the camera. No attempt should be made to turn **the camera by hand** or serious damage may result. The occurrence of buckling will be indicated by the noise of the film crumpling inside the camera before the **motor is** stopped by the buckle trip switch. **As soon as the motor stops proceed as follows:**

1. Turn power OFF.
2. Remove belt from take-up pulley on magazine and take up the excess film in camera by turning the pulley by hand.

CAUTION: Do not allow **the** magazine belt to move the mechanism inside the camera while taking up the excess film. Operation of the camera movement at this time may cause serious damage. If the film is so tightly jammed that it cannot be taken up by rotating the pulley, it will be necessary to open the camera door and free the film before winding it up on the take-up spool.

3. Open the camera door and remove the aperture and pressure plates. Examine the film aperture to be sure that no pieces of tom film are

obstructing the light passage. Examine the registration pins and pulldown claw to make certain they have not been bent. Examine the slots and holes in the aperture plate to make sure that punched pieces of film have not lodged there. Make certain all torn pieces of film are removed from the camera.

4. Rethread camera and reset buckle trip by pulling out knurled reset knob (17).

5. Run a short length of film through the camera, then remove and examine it carefully under a magnifying glass to see that no scratches are present on emulsion and perforations are undamaged.

CHANGING LENS MOUNTS

CAUTION: Before removing or changing lensmounts, the optical block should be removed from the camera. See Optical Block in Section 1, page 6 .

Interchangeable lensmounts are available for Nikon, Canon, Olympus, Contax (ZEISS), and BNCR mounted lenses. All lensmounts are interchangeable and can be ordered on standard Academy centerline or on full-frame silent centerline for those shooting background plates, etc. However, due to the special nature of the Canon lensmount, it cannot be added later, but must be ordered at the time of the initial reflex conversion.

The lensmounts are attached to the camera body with four screws, as shown in sketch below.

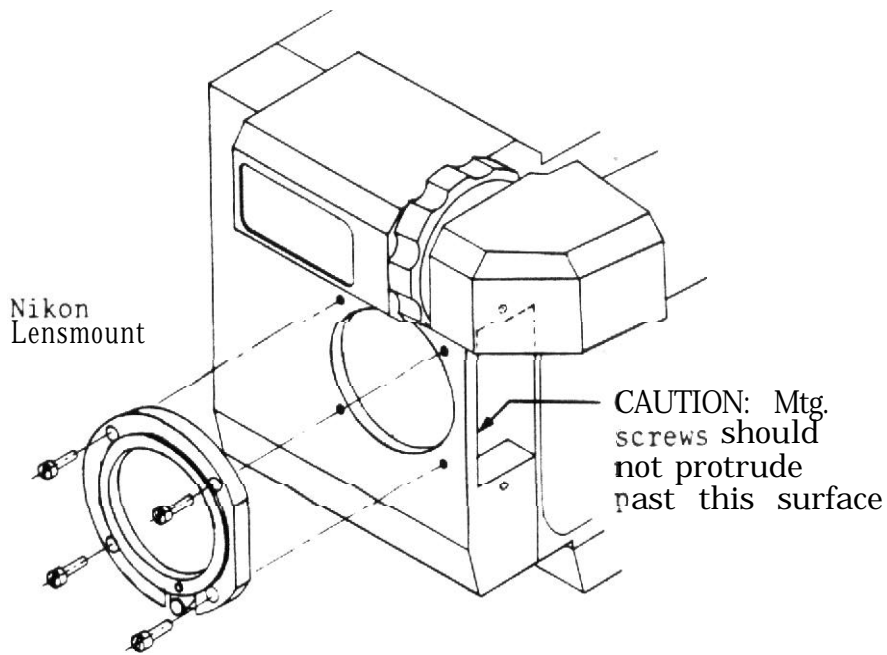

CAUTION: When attaching the lensmount to the camera body, check to make sure none of the mounting screws protrude through the front wall into the optical block area.

LENSES

The following list of lenses are compatible with the 35R:

Nikon : all lenses except the older *fisheyes* that required mirror lock-up on the Nikon camera.

Canon: all lenses.

Olympus: all lenses.

Contax (ZEISS): all lenses.

BNCR/Mitchell/Mobil Optics High Speed: all lenses.

BNCR/Bausch & Lomb Super Baltar: all lenses. **CAUTION:** Some 50mm F2 lenses require slight rework.

BNCR/Cinema Products/Canon Ultra Fast: all lenses except the 18mm T2.8.

BNCR/Kowa Cine Prominar: 100mm T2.3, 75mm T2.3 & 50mm T2.3 are compatible. 40mm T2.3 & 25mm T2.3 prevent removal of the optical block while the lens is installed. 32mm T2.3.

CAUTION : 32mm T2.3 Some lenses may require slight rework. 20mm T2.3 & 15mm T4 will not fit.

CAUTION: All Canon lenses must have the auto-iris control lever locked in the manual position. This accomplishes two things. First it engages the iris (or diaphragm) control ring for direct manual control of the "F"-stops. Second, it positions the lever to clear the beamsplitter in the reflex conversion. IF THE LEVER IS NOT LOCKED IN THE MANUAL POSITION, POSSIBLE DAMAGE TO THE BEAMSPLITTER COULD RESULT FROM INSERTION OF THE LENS. On older lenses (where just the silver lock ring turns) the lever is pushed counter clockwise until it locks into position with a positive feeling detent. On newer lenses (those that the entire lens turns on installation or removal) a special plastic insert must be purchased from a Canon dealer. The iris control lever is held in the extreme counter clockwise while the plastic insert is installed in the slot to hold the lever in place.

GROUNDGLASSES

The groundglass is readily interchangeable and available for all standard formats including: 1.85/TV, 1.33/TV, 1.85/1.33, 1.66, 2.35, & etc. Specials can be made to customer requirements.

The groundglass is part of the optical block assembly. To change groundglass, see Optical Block sketch in Section 1, page

FILM CLIP

A special feature of the 35R is the ability to insert a film clip in the viewfinder. The clip is positioned on a set of precision aligned register pins, and therefore, needs no special punch. The clip is viewed simultaneously by the operator and the optional video assist. The film clip is located in the optical block assembly; see Optical Block sketch, Section 1, page .

FILTER HOLDER

An internal gelatin filter holder is located in front of the aperture, but outside of the viewing system. This design maintains full viewfinder brightness with any filter inserted. The required size is 1" x 2", which can be obtained by cutting a standard 2" x 2" in half.

The filter holder is located at the back of the optical block. For adding inside gelatin filters, see Optical Block, Section 1, page .

SHUTTER ADJUSTMENT

Variations in shutter opening from 170° to fully closed can be made while the camera is in operation or the shutter may be locked in position at 10° increments. This exposure change is made by moving the hand dissolve lever on the rear of the camera. The knurled locking pin at the outer end of the lever can be pulled out and turned so that the pin will clear the holes on the segment 10°. The lever can then be moved smoothly for fades. As the **camera** speed is increased, the shutter exposure time is reduced.

FOOTAGE COUNTER

The dial counter should be reset to zero whenever a new magazine is installed on the camera. A knob at the center turns the pointer. The frame and footage counter can be used to record the footage of film used for an individual scene. The reset handle is directly to the left of the counter windows. The last window on the right of the footage counter registers individual frames and is marked in increments from one to sixteen. (There are sixteen frames per foot of film). The frame counter does not reset to zero with the footage counter.

MATTE BOX

The 35R is designed to accommodate both the lower original CC matte box or the Mitchell BNCR Side Swingaway type matte box. The lower GC Rod Holder is mounted to the underside of the front casting with two locating pins and one large captive screw. The Side Swingaway BNCR Rod Holder is mounted to the motor side of same casting, and is mounted with two captive

screws, and a square key slot. Both can be used on the camera at the same time; the side for a matte box, and the lower for a zoom lens support, etc.

VIDEO ASSIST

Installation:

First, remove the optical block, (See Section 1, page), next, remove the viewfinder assembly. This is accomplished by removing the three allen cap screws, and carefully lifting the housing up and forward.

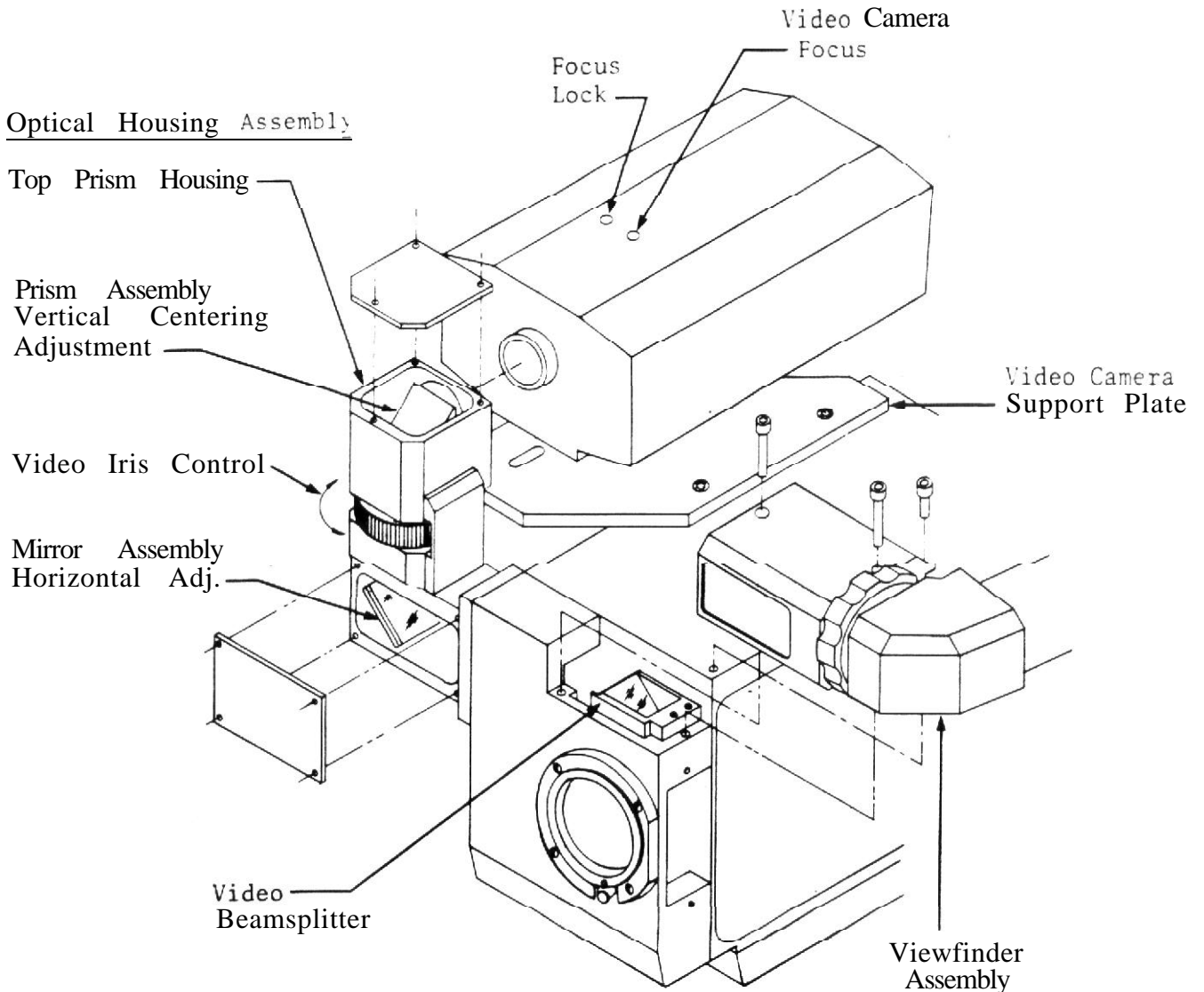

Then install the video beamsplitter assembly with its two mounting screws as shown. Remove the video cover plate, and install the optical housing assembly to the motor side of the camera as shown above.

Screw the video camera support plate to the top of the 35R camera body as shown. Mount the video camera to its support plate and align front with the optical housing port.

Reinstall camera optical block and viewfinder assembly.

Alignment Procedures:

NOTE: All alignment and focus procedures are easier to accomplish with the film camera prime lens removed or pointed at a blank white card, allowing the video system to see the groundglass reticle only.

Optical alignment involves the centering of the groundglass image on the faceplate of the video tube by adjusting (repositioning) a mirror and a prism in the optical path.

To reposition the image vertically, remove the three screws and cover on the top prism housing and loosen the two inside screws that lock down the prism assembly. Slide the prism assembly forward or backward until the image is centered, lock down the two screws and replace the cover plate.

To reposition the image horizontally, remove the four screws and cover plate of the lower mirror housing. Loosen the two inside screws, tilt the mirror to achieve horizontal center, and lock the two screws down on the mirror bracket. Replace the cover plate.

Electronic centering can also be used to correct the image. Inside the video camera are trim pots labeled: "VC", vertical centering, and "HC", horizontal centering. Normally these controls are preset to approximately their middle range, and all corrections are made mechanically as previously

described. This assures your image of being in the center of the faceplate of the tube. If necessary, these controls can be used to make minor adjustments.

Focus :

Two focus controls are available. Mechanical focus is found on top of the video camera. First, loosen lock screw. Next, use flat tip screwdriver (not Philips) to turn the internal cam that moves the video in and out of focus. After finding sharpest focus, tighten lock screw.

An electronic focus is located inside the camera on a trim pot labeled "FOC". This control is normally factory set, and does not need readadjusting until the tube ages. If you have adjusted the mechanical focus for optimum sharpness and are still not satisfied, carefully adjust the trim pot to its sharpest position. If you are not sure of any improvement, return the trim pot to its original position.

Connections:

Video out is through a standard BNC shielded connector on rear Of video camera. Power into the camera is through a screw type terminal strip mounted on the rear of the video camera. The camera requires a standard 12 VDC supply although anything from 10.5 VDC to 16 VDC will work. The terminal strip is marked (+) and ground. The connection marked LL is not used. The camera consumes about 7 watts.

SECTION III - Maintenance

CLEANING CAMERA BOX

The interior of the camera must be cleaned after each period of use. The cleaning is usually done with an air syringe to blow off loose dust, a camel's hair brush to dislodge clinging foreign material, and a lintless cloth for wiping polished surfaces. To clean the camera box interior, proceed as follows:

1. Open the camera door and remove the aperture plate and pressure plate. (See page 27)
2. Vacuum all loose dust from the mechanism and from the corners of the camera box.

NOTE : The camera shutter should be in the closed position during cleaning so **that** the dust does not go into the viewing optical system. When camera is run without film or pressure plate--excess oil from movement may be slung onto the beamsplitter.

3. Use camel's hair brush to get into corners and **around** the sprocket and guide rollers. Make sure all bits of emulsion or film are removed.
4. Wipe the polished metal surfaces carefully with soft, lintless cloth.
5. With the camel's hair brush, remove from the mechanism and interior of the box any threads or foreign material that may have been loosened by the cloth.

CLEANING THE BEAMSPLITTER

The beamsplitter is fragile and should be cleaned and handled only when necessary, and with extreme care.

The beamsplitter is a part of the optical block assembly. Remove the optical block as explained in Section 1, page 6.

Section 111

Cleaning Camera Box:

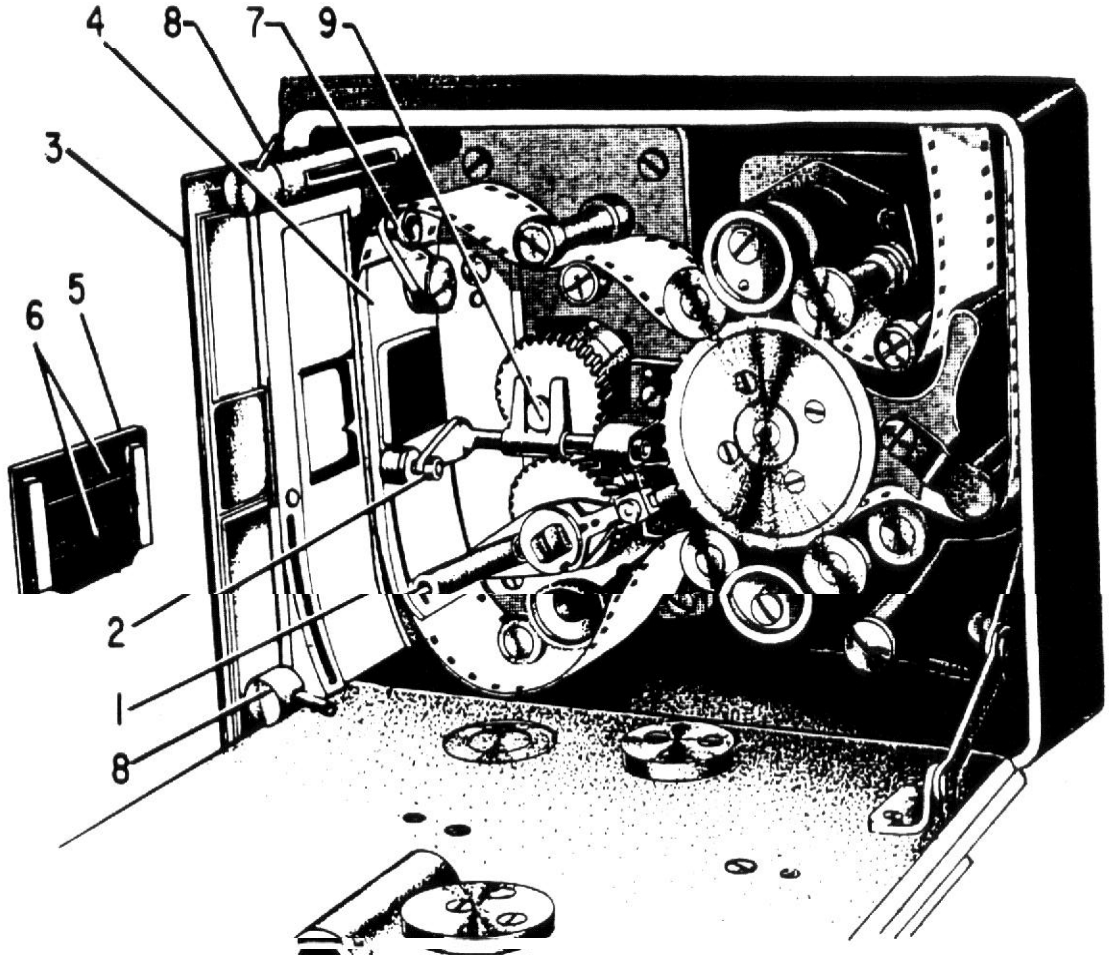

1. Pulldown arm.
2. Pilot pin.
3. Aperture plate.
4. Register plate.
5. Pressure plate.

6. Pressure plate rollers.
7. Pressure plate retaining arm.
8. Aperture plate locks.
9. Movement cam.

1. For dust or light dirt specs try using a clean, soft camel hair brush; brushing the beamsplitter surface lightly.
2. After brushing, if **there** are still a few small specs or oil spots, try using standard lens cleaner and lens tissue. Do not apply any pressure to the beamsplitter surface.
3. For more stubborn dirt or oil spots. **A** thorough cleaning is required. To thoroughly clean, the beamsplitter holder must be removed from the optical block which is explained in Section 1.

CAUTION: Do not try to remove the beamsplitter glass from its holder. The beamsplitter in its holder should be submerged in a mixture of liquid detergent soap and **warm** water. ($1/3$ water; $2/3$ liquid detergent). Let soak for approxiametely 5 - 10 minutes. Rinse thoroughly with clean warm water and wipe dry with lens tissue.

PRECAUTIONARY NOTE: If beamsplitter is not wiped dry, but allowed to dry in air, a stain may result which will permanently damage the coating.

Liquid detergents which have been used and yielded satisfactory results are, "Joy" and "Glim". Both are available at most grocery stores.

CLEANING PRESSURE PLATE

The pressure plate must be inspected and cleaned each time the aperture plate is cleaned.

1. Remove pressure plate from camera by swinging retainer **arm** upward and lifting plate out.
2. Remove all loose dust and bits of emulsion with a camel's hair brush.
3. Wipe the forward side of the plate with the ball of the thumb to remove all loose dust **and bits** of **emulsion**.
4. Test the rollers to see that they revolve freely. If they show a tendency to stick, immerse the pressure plate in cleaning solvent, **re-**

volving the rollers while they are in the fluid. Dry the plate thoroughly with a clean, lintless cloth; then use an air syringe to evaporate the solvent that may be adhering to the roller bearing pins. When the plate is dry, apply a minute amount of camera oil to the roller with a toothpick. Be sure to wipe off all excess oil.

CLEANING APERTURE PLATE

Clean aperture plate at least every 1000 feet or each time the camera is threaded.

1. Turn camera to threading position.

2. Pass a piece of film between the register plate and aperture plate to ascertain that registration pins and claw are fully retracted from aperture plate.

CAUTION: Failure to check this may result in damage to the aperture plate.

3. Turn the two aperture plate locks until the pins point upward, then carefully slide aperture plate straight out of camera.

4. Inspect for bits of emulsion on aperture plate. Clean aperture and film race with a camel's hair brush.

CAUTION: Never use abrasive cleaners.

5. Remove accumulated emulsion from the film race, the registration pin holes, and the pulldown claw travel slots using an orange stick or any other type of pointed, soft wooden prod.

6. Blow through the registration pin holes and the claw slots with an air syringe.

7. Polish the film race with the heel of the hand. Place a drop of Mitchell Camera Oil on the film race and rub it in thoroughly with the thumb or heel of the hand to remove all excess oil. The hand must be free of grit and perspiration. Be sure the registration pin holes and claw slots

are dried completely.

CLEANING FILM MOVEMENT

The movement ~~must be~~ kept clean at all times. If salt water, sand, or any other foreign material enters the **movement**, it should be thoroughly cleaned as follows:

1. Remove and clean aperture and pressure plates.
2. Remove the flywheel from the movement shaft. The flywheel is held onto the shaft with a retaining screw and lock screw key.
3. Remove the three screws which hold the movement to the camera box and withdraw the movement. Be careful of exposed registration pins when aperture plate is removed.
4. Immerse the movement parts in solvent and clean them with a soft brush. Remove all oil and grease.
5. Blow all parts dry with air or wipe them dry if air is not available.
5. Lubricate the movement by oiling or greasing all points shown on lubrication chart. Force grease into the ball-bearing races. Force three drops of oil into pulldown arm ball-bearing.
7. Reinstall aperture and pressure plates.
8. Time movement as in following paragraph when replacing it in camera. Whenever movement is removed from camera box it must be retimed with the shutter. Do not attempt to operate camera if movement and shutter have not been placed in proper synchronization.

TIMING THE MOVEMENT

The camera movement must be timed whenever it is taken out of the camera. The timing operation consists of synchronizing the movement and shutter so that the shutter is closed whenever the film is in motion and

open when the film is registered, and motionless in front of the aperture. Thus, when the `pull-down` claw is engaging or leaving the film sprocket holes, the shutter must be closed.

1. Insert movement in camera box and **secure** it with the three screws provided.

2. Turn the large brass gear in the right side of the camera box until the punch mark on this large gear is opposite the scribe mark on the stop motion gear.

3. Slide the flywheel into position so the index mark on the rim of the flywheel is slightly above the index mark on a spoke of the large brass gear.

4. As the flywheel gear is pushed into mesh with the large gear, it will rotate counterclockwise. This should bring the index marks together, and at the same time the rounded portion of the stop motion shaft should be at the top.

5. Replace the flywheel retaining screw and lock screw.

6. Place a small amount of grease on all gear teeth.

CHECKING TIMING

1. Remove the taking lens from front **of** camera.

2. Set the shutter lever at 170° .

3. Insert a strip of film in the film race.

4. Turn the movement slowly, causing the arrow on the cam to turn clockwise until the registration pins touch the **film**. At this point the shutter should be just starting to open. (About $1/8$ inch of the shutter opening will be visible in the lower left-hand corner of the aperture.)

SECTION III - Timing the Movement

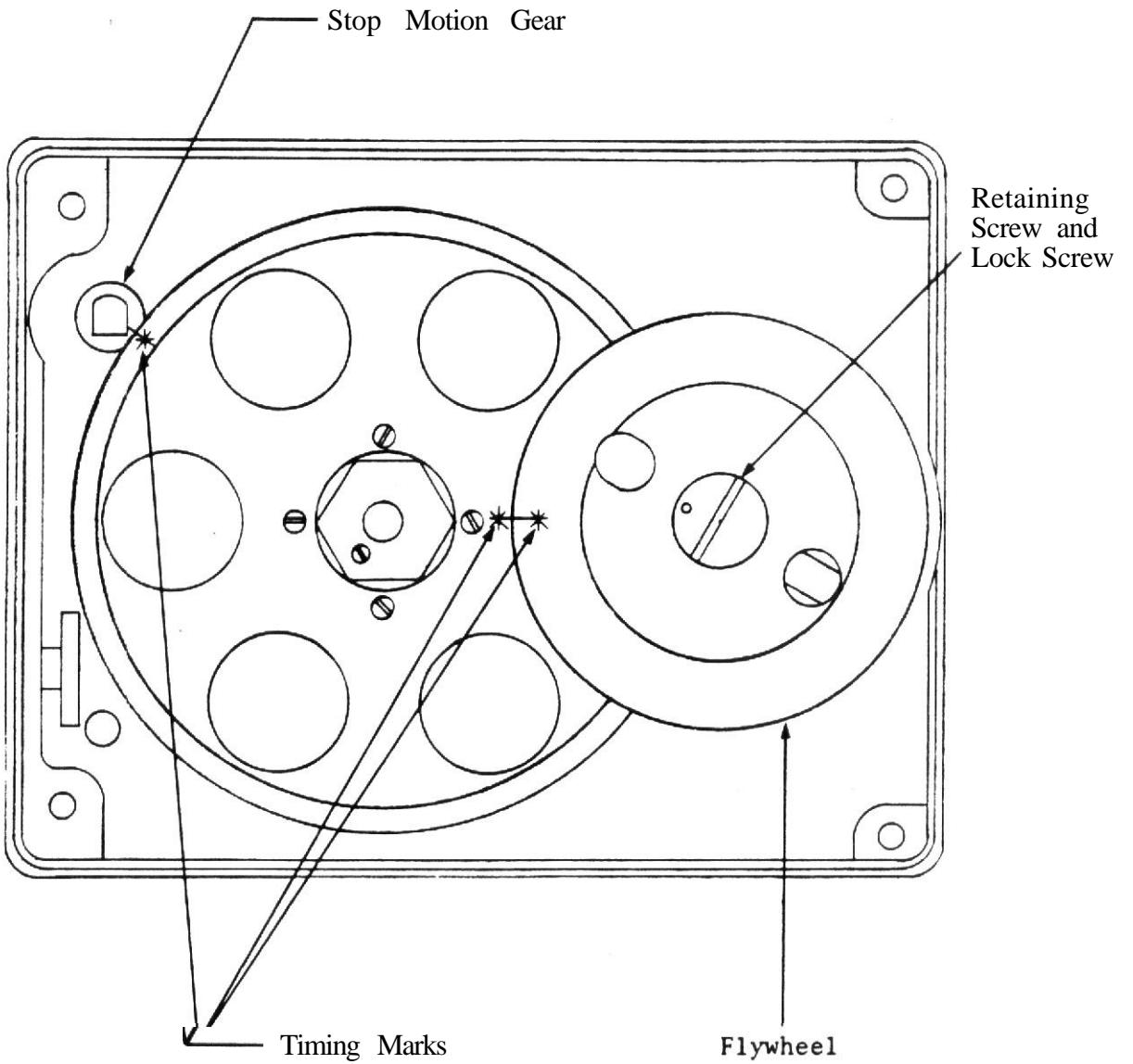

5. Turn the movement so the cam arrow rotates counterclockwise until the registration pins touch the film. At this point the shutter should be closed except for about 1/8 inch of opening in the upper right-hand corner of the aperture.

LUBRICATION

Use Mitchell Camera Oil for all lubrication points requiring oil. The lube points shown in the movement sketch should be lubed after every 1000 feet of film; especially when running at high speed. All other idler rollers, sprocket guide rollers, and keepers need only to be lubricated after every 50,000 feet of film.

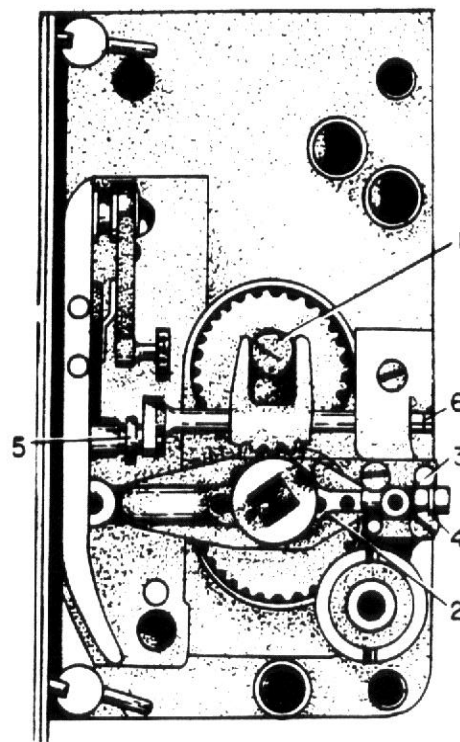

1. Movement cam.
2. Pull-down arm oil hole.
3. Pull-down arm rear support.
4. Pull-down arm shaft.
5. Pilot pin front guides (2 lube points).
6. Pilot pin rear guide.