



Users guide 2004-02-19

Congratulations for the acquisition of A-Cam by Ikonoskop.

This guide will take You through the basic handling and operation of A-Cam.
Please carefully read the entire guide before using A-Cam for the first time.

If you have any question regarding A-Cam and can not find the answer in this guide,
please contact us directly.

Ikonoskop AB
Virkesvägen 2A
S-120 30 Stockholm, Sweden
phone: +46 8 673 62 88
e-mail: info@ikonoskop.com

1. Technical specifications

Body	Milled aluminium shell
Socket threads	3/8" and 1/4"
Weight	1540g incl. lens, film and batteries
Measures	238 mm x 108 mm x 64 mm
Lens mount	C
Film format	Super 16 = 1:1,66 = 15:9
Film capacity	30,5 m/100 ft
Frame rates	6, 10, 12,5, 18, 20, 24, 25, 30, 36, 37,5 fps*
Shutter angle	160°
Time lapse	1 fps – 1 frame/24 h
Standard optics	Kinoptik 9 mm f/1.5
Power	12 V
Battery	Internal, also runs of external 12 V supply
Viewfinder	Magnetically fitted parallel mounted, non-reflex

*= Speeds 30 and 37,5 fps requires external power of 12V or 15V.

2. Camera Views

left side/front

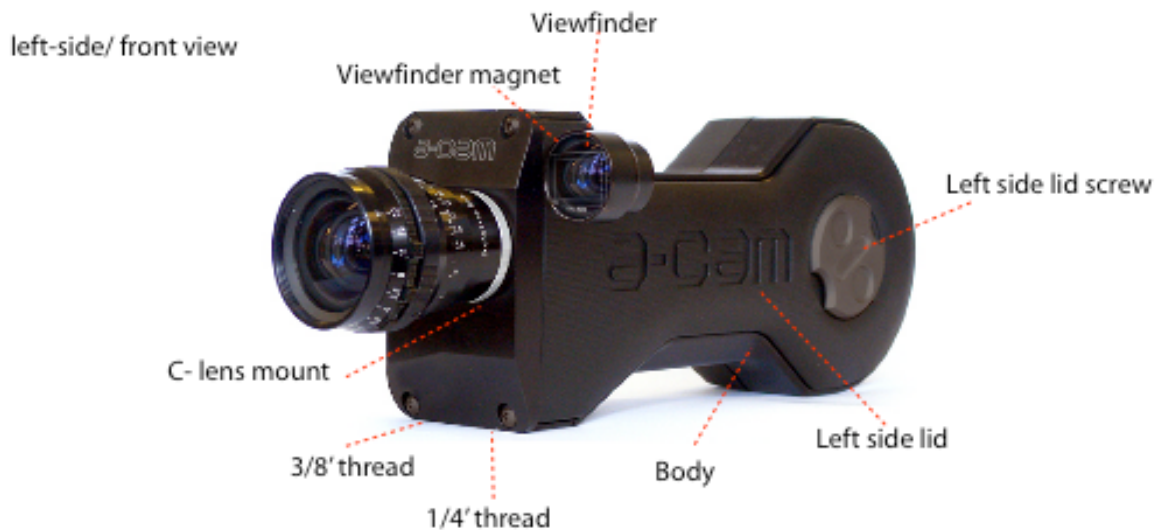

right side

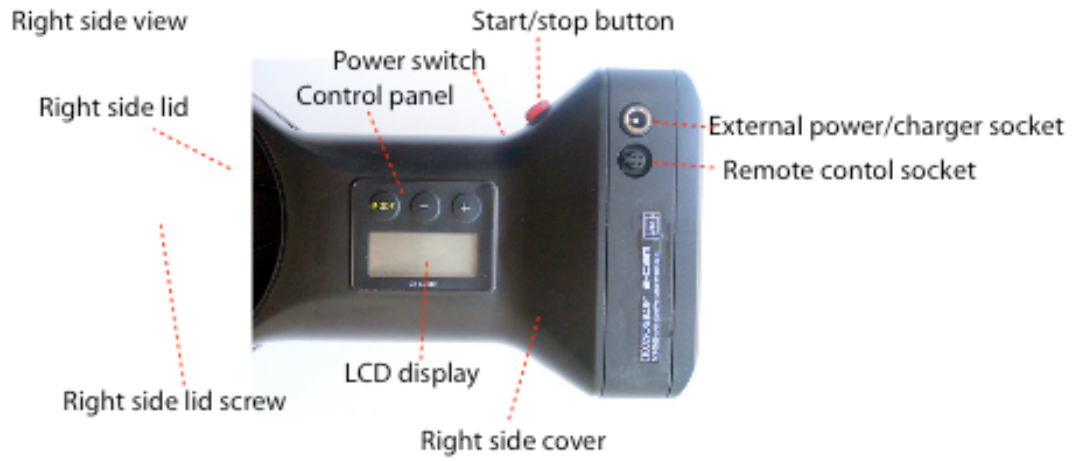

left inside

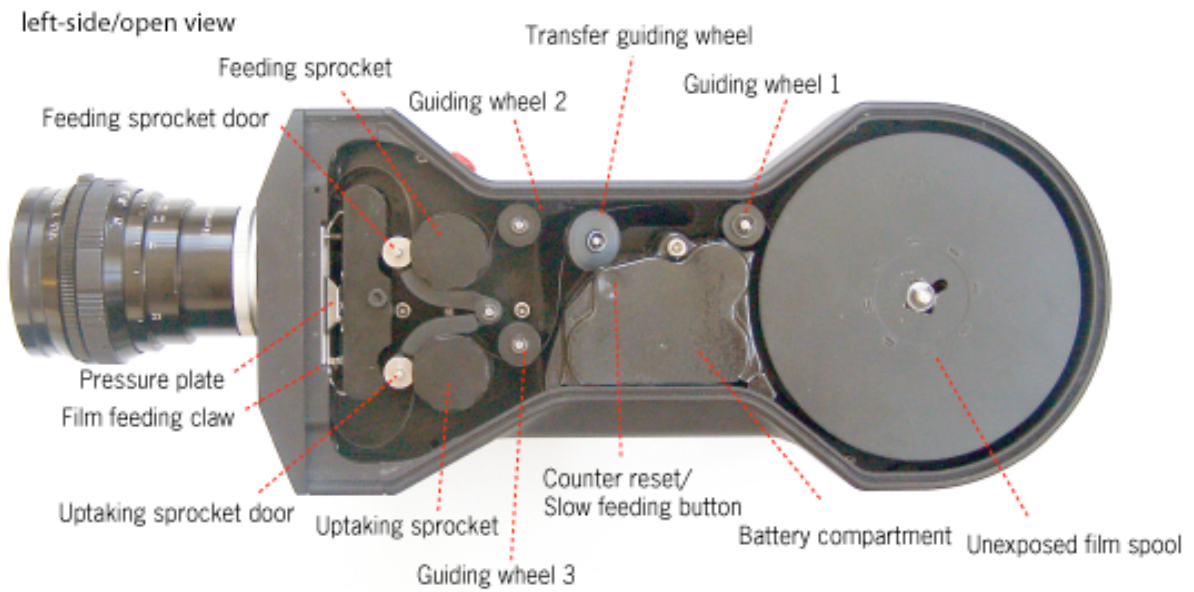

4. Introduction

A-cam is designed to be the smallest and lightest professional film camera known to mankind. The contemporary filmmaker, used to modern video cameras might find the world of film cameras a little more demanding. This should be no obstacle. Using 16 mm film is fun and easy, once your in.

The film is loaded directly into A-cam and it therefore lacks interchangeable magazines. The loading can appear a bit tricky the first times, but every mechanism is visible and easy to check. Just take Your time and follow the steps in this guide..

The A-cam has no handle. It's a handle itself. Of course you can handle it anyway you like, but we recommend You to take a look on the following pictures, in order to find Your own way.



5. Switches and sockets

The power switch turns the main power on and off. The power is switched on when the switch is in it's front position, and off in its rear position.

The Power Switch does not have to be turned on when charging the internal battery.

The start/stop button makes the camera run at selected speed. The function of this button can be altered in the STRT/STP- menu. See section 7 for details.

The external power/charger socket is used to connect the camera to an external power supply or the battery charger.

Please note that a charger or an external power supply must NEVER be connected to the camera when using a single-use lithium battery pack.

The remote control socket is used to connect the camera to a remote start/stop unit.

6. Loading and threading.

The a-cam loads with 30,5/100 ft daylight spools available in all emulsions from Kodak. That means A-Cam does not have to be loaded in complete darkness. Bright light and dust should be avoided though. Find a dim and clean place for Your loading.

To load A-Cam , just follow these steps:



1. Open the left side lid by unscrewing the left side lid screw.



2. Extract ca 40 cm of film from the unexposed film, with the perforations facing down.



3. After placing the spool in place, lead the film upwards between the battery compartment and the spool, and anti-clockwise round Guiding wheel 1



4. After rounding guiding wheel 2 anti-clockwise, release the feeding sprocket door from the feeding sprocket and lead the film in between them. Make sure the cogs of the feeding sprocket snaps into the perforations of the film.

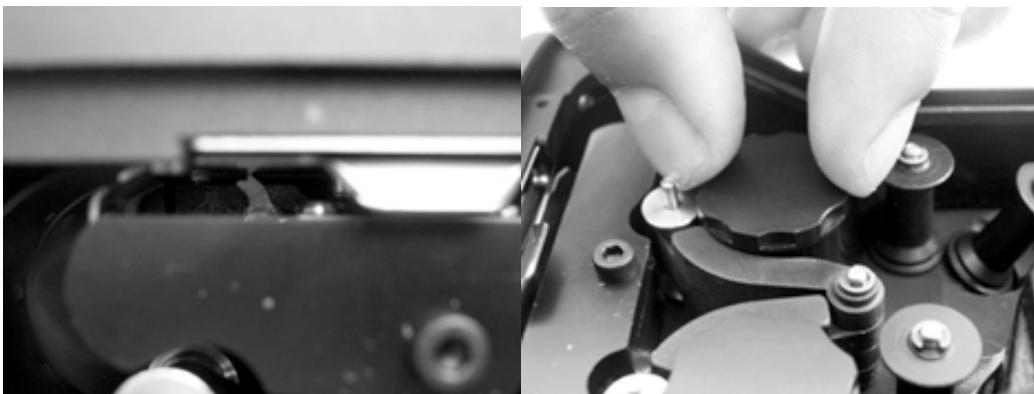

5. Make sure the Film feeding claw is in it's ejected position. If not, turn the knob of one of the sprockets until the Film feeding claw is ejected.



6. Carefully bend the film anti-clockwise to create the upper part of the loop, and release the pressure plate, before inserting the film between the gate and the pressure plate with the loop maintained.

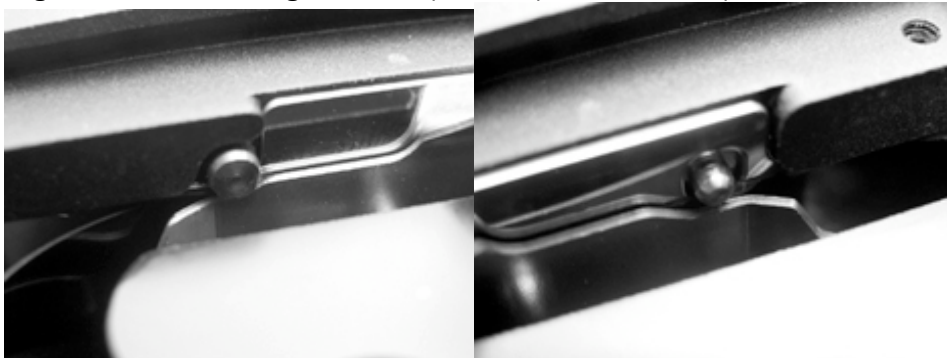

7. Make sure the pressure plate snaps pack properly

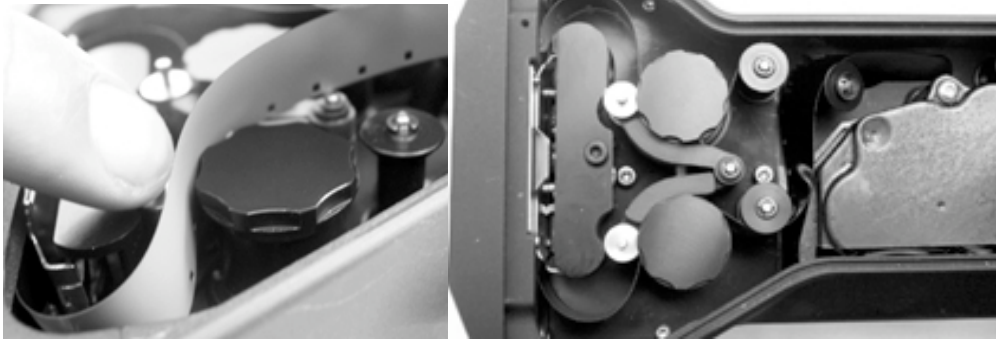

8. Make the lower part of the loop and guide the film between the Uptaking sprocket and the Uptaking sprocket door. Adjust the size of the loop to the preferred size (see above), without turning the sprockets, but releasing it with the sprocket doors.



9. Lead the film anti-clockwise round Guiding wheel 3 and then over to the uptake side via the Transfer guiding wheel.



10. Turn the Feeding sprocket clockwise to ensure the feeding works smoothly.



11. Press the counter-reset button to reset the counter. (Make sure the main power is switched on) Then close the left side lid.



12. Turn the camera over and unscrew the right-side lid. About 10-15 cm of film will be visible. Test the threading by running the camera while pulling the film.



13. Thread the film clock-wise round the guiding wheel in the uptaking compartment. Then insert the end of the film in the chink in the centre of the empty spool. Wind up the remaining film anti-clockwise on the empty spool and put it in place. Make sure the end of the film is locks onto the core of the spool and that the square hole in the spool fits on the square part of the axle.



14. Close the right side lid. For optimal performance, tighten the lid gently without unnecessary force.

7. The Menu and control panel

The control panel allows You to set different parameters for the operation of A-Cam and also displays information on battery status, elapsed film and frame-rate in operational mode.

The control panel consists of a back lit LCD display and three buttons to set and change different parameters.

- The MODE button allows You to step between the different modes and also sets the chosen parameters and values for each mode.
- The + and - buttons enables You to step between different parameters and values within a certain mode. The + button also activates a certain sub-menu/mode

When A-Cam is switched on the display first shows the software version for the camera for three seconds.

Frame rate

The Frame rate menu lets You select different frame rates.

Press the MODE button until FPS is displayed, then press + to activate the FPS sub-menu. Use the + and – buttons to select frame rate. Then press MODE to leave the sub-menu and activate the selected frame rate.

Intervalometer

The Intervalometer menu lets You select regular single frame exposures in a chosen interval.

Press the MODE button until INTV is displayed, then press + to activate the INTV sub-menu.

Use the + and – buttons to select interval. Then press MODE to leave the sub-menu and activate the selected interval.

Note: When shooting long-interval time lapse, the equipment gets more sensitive to light leakage. How much depends on environmental light, film speed and aperture. Take necessary measures to cover the equipment and run tests.

1 frame exposure

Press the MODE button until 1 FRM is displayed, then press + to activate the 1 FRM mode.

Pressing the start/stop button will now expose a single 1/30 sec frame. This mode is now in function until another mode is chosen.

External synchronization / master/slave chain.

This function is not implemented in this camera.

Setting start stop mode

The start stop menu lets You select operational mode of the Start/stop button.

Press the MODE button until STRT/STP is displayed, then press + to activate the STRT/STP sub-menu.

Use the + and – buttons to select function.

1 CLICK is the default mode, and makes the camera run and stop by pressing the Start/stop button once.

2 CLICK makes the camera run and stop by pressing the Start/stop button twice.

TOGGLE makes the camera run while the Start/stop is pressed and to stop when it's released.

Press MODE to leave the sub-menu and activate the selected function.

Setting background light.

The background light menu lets You select operational mode of the LCD display.

Press the MODE button until LIGHTLCD is displayed, then press + to activate the LIGHTLCD sub-menu.

Use the + button to select function.

DEFAULT is the default mode, where the background light of the LCD display is lit when operating the control panel.

OFF turns the backlight off.

Press MODE to leave the sub-menu and activate the selected function.

A-CAM MENU SYSTEM OVERVIEW

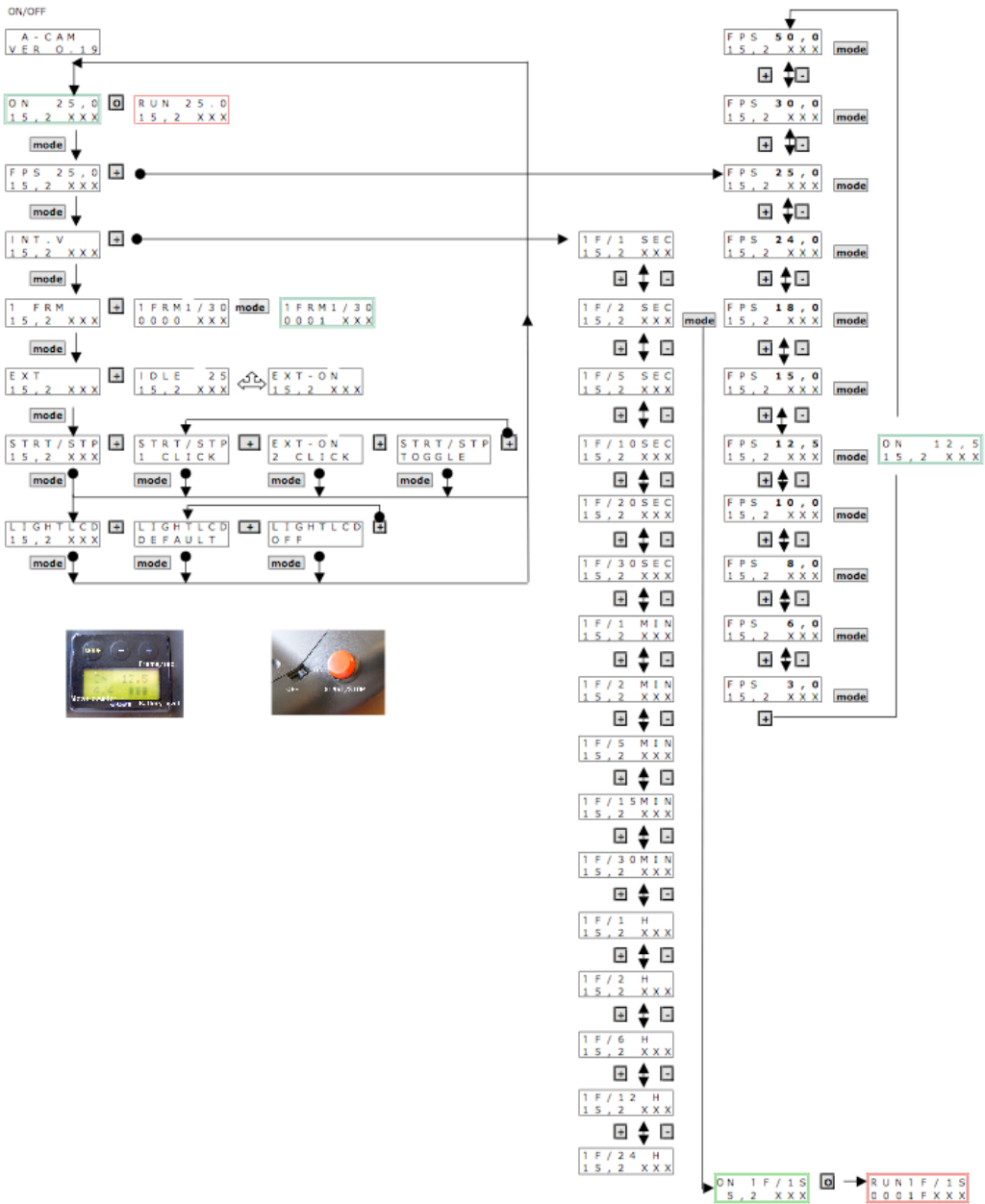

8. Shutter synchronization

The opening angle of the shutter is 160° . To check the synchronization of the shutter to the feeding mechanism, first unscrew the lens and remove the left side lid.

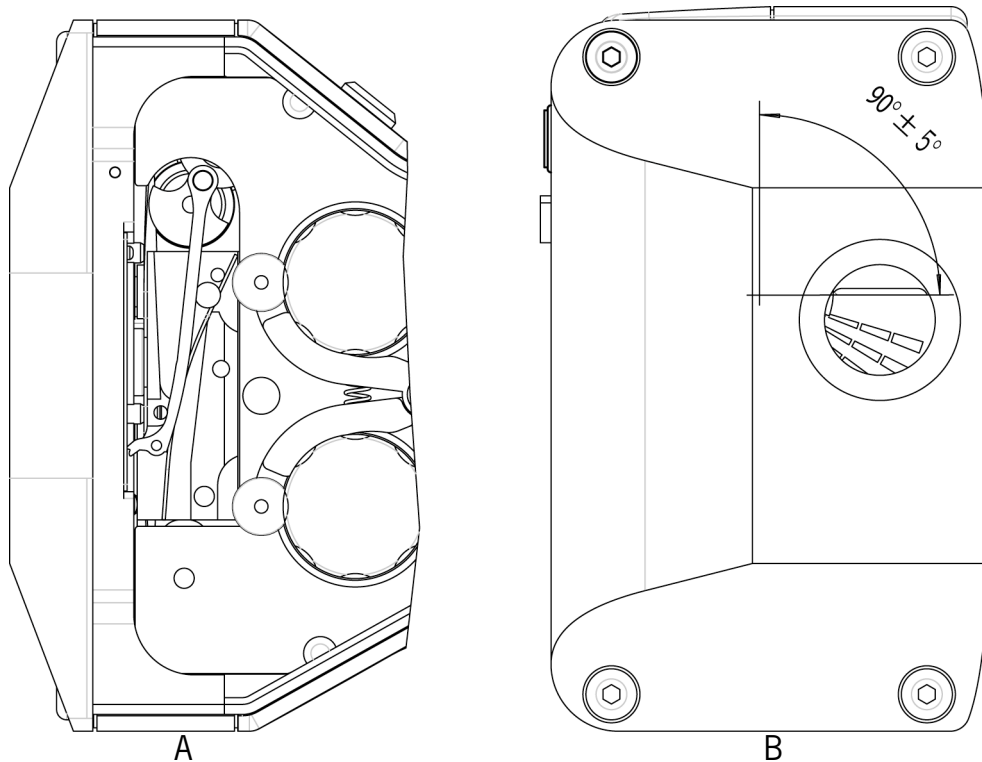

To check if the synchronization is correct, turn one of the sprockets until the feeding claw is in the position of Fig. A. Then look in to the gate and make sure the shutter is in the position in Fig. B $\pm 5^\circ$.

If the shutter is out of position, unscrew the four screws of the camera front and carefully remove the front while facing in upwards.

Then carefully remove the shutter vertically and put it back in the right position.

When shooting under violent circumstances, we recommend checking the shutter synchronization after every 2 rolls of film.

9. Lens

A-Cam is delivered with a 9 mm prime-lens by famous French lens manufacturer Kinoptik and is exclusively manufactured for Ikonoskop.

The lens is fitted to the camera body with a standard C-mount.

The lens has three scales.

The aperture scale indicates the different full f stops between 1.5 and 22. The T stop is 1.7

The focus scale is graded in meters from eternity to 0.25 m. The closest possible distance of focus (focus-ring in its extreme position) is approx. 2,5 cm though.

The depth-of-field scale. Decreasing the aperture (increasing the numbers) will increase the depth of field. To make that more obvious, the lens is equipped with a scale displaying the depth of field for a certain aperture.

10. Viewfinder

The viewfinder is parallel-mounted on the left side of the camera body and is fitted to the left-side lid with a magnet.

The framing is set for a 9 mm lens with a range interval 5m – eternity. Parallel to the left and upper side of the frame is a broken line indicating the difference in framing for a distance of one meter.

For accurate framing, keep the eye approx. 1 cm behind the rear of the viewfinder.

11. Batteries

There are two battery options for A-Cam



- a) **Single-use Lithium Battery pack** (Standard shipping option)
1400 mAh, 70 g, Runs >25 rolls at 25 fps at 20°C
Please note that a charger or an external power supply must NEVER be connected to the camera when using a single-use lithium battery pack.



- b) **Rechargeable Li-ion battery** (Optional)
480 mAh, 46 g, Runs >25 rolls at 25 fps at 20°C

The batteries are located under the Battery Compartment Cover on the left side of the camera. To change the battery, unscrew the Cover and carefully tweak it out. The batteries are connected with a socket on the left in the Compartment.

Please note: Rechargeable batteries are charged in place and therefore does not need to be removed.

12. Battery charger



The battery charger is designed for 220-230V or 110-230V. When the charger is connected to the camera DC socket a orange light is lit. When the batteries are fully charged (may take up to 6 hours) the light turns green.

Please note that a charger or an external power supply must NEVER be connected to the camera when using a single-use lithium battery pack.

For more details on the charger, please see attached instructions.

13. Notes

- When not using A-Cam, turn the Power switch off, in order to save battery stamina.
- Avoid pressing the window of the LCD display.
- Due to A-Cams sync control cycle, it might be sensitive to flickering light. Run tests to avoid problems..
- NEVER connect the charger or an external power supply to the camera when using a single-use lithium battery pack.
- In software 0.24-0.32, 50 fps can be selected from the framerate/FPS menu. This is a software bug. **50 fps is not an authorized framerate and shall not be used. Ikonoskop is not responsible for errors occurring from such use.**
- In software 0.32, when selecting 25 fps, there is a warning saying "EXT POWER MIN 12 V". This message is a software bug and can be neglected. 25 fps can be run on internal battery.