

FRITZ GABRIEL BAUER
PRESENTS

THE USERS GUIDE TO THE NEW
LIGHTWEIGHT QUIET MODULAR

NOVICAN
COMPACT

THE ADVANCED MODULAR QUIET 35 mm
MOTION PICTURE CAMERA FOR MULTIPLE
APPLICATIONS AND INCREASED UTILIZATION

WEB-EDITION 2004

Compiled by Frédéric Gérard Kaczek
Illustrated by Andreas Pauleschitz

PREFACE

Contemporary cinematography demands broader knowledge and greater skill from today's cameramen than ever before. Movie or TV productions, documentary films, advertisements, STEADICAM or aerial shots - these are only a few out of a wide range of different tasks.

So far, the inventive and creative Director of Photography had to get hold of a camera and accessories suitable for his special task. One camera was a bit smaller, another one a bit lighter, a third one quieter, and another one had special equipment. And so it was a real challenge for us to develop a system which allows each cinematographer to set up the appropriate equipment for each particular job more easily than ever before.

*The **USERS GUIDE** for the MOVICAM COMPACT we present you herewith is not simply a guide to a new camera but an introduction to the quietest compact*

35 mm camera system for multiple applications and increased utilization.

Please take the time to read the following pages carefully. You will see that this new camera system offers you a great variety of possibilities.

For further general or technical information, please feel free to contact one of our MOVIECAM rental houses or directly the MOVIECAM Headquarters in Vienna, Austria (for addresses and phone numbers, see appendix).

Fritz Gabriel Bauer and Team

MOVIECAM FEEDBACK MAIL

*Like the MOVIECAM COMPACT system itself, its users guide consists of several interchangeable parts that will continuously be updated. Just send an E-mail by pushing **HERE** directly to the Vienna Headquarters and future updates will be mailed to you free of charge. You may also use this mail to let us know any comments (e.g. proposals, or – if really necessary – complaints) you may have*

MOVIECAM COMPACT CHECKLIST

The attached checklist (see appendix), which is ready to be printed out, gives a general overview of all modular parts of the MOVIECAM COMPACT and might be of help when placing your order.

CARE AND CLEANING

The MOIECAM COMPACT is almost maintenance-free. There is only one requirement for a smooth operation: **the camera has to be meticulously clean.** Therefore you should protect it against any dirt or smudges.

Clean the camera exterior with window cleaner (caution – do not moisten connectors!).

Only when really necessary, e.g. to remove camera tape gum, should you use alcohol or benzine.

Caution: Never use acetone!

When applied properly, compressed air is the best cleaner; a vacuum cleaner or an air syringe will do fine.

Cotton tips, orangewood sticks, soft and hard brushes may be used for gentle cleaning.

Caution: The camera may be lubricated at a MOVIECAM rental house only!

TABLE OF CONTENTS

	PREFACE	2
	MOVIECAM FEEDBACK MAIL	3
	COMPACT CHECKLIST	3
	CARE AND CLEANING	4
	THE COMPAC SYSTEM	9
1	THE BODY OF THE CAMERA SYSTEM	
	Camera front	16
	Camera left side	17
	Camera rear	19
	Camera right side	20
	Control board	21
	Display	22
	Camera top	24
	Viewfinder mount plate	25
	Camera base	26
	BASE PLATE	27
2	THE VIEWFINDERS	
	STANDARD VIEWFINDER	32
	EYEPIECES	33
	Eyecup and Eyepiece retaining mount	34
	Diopter correction	35
	Adjustment of the pivoting viewfinder	36
	Adjustment of the image orientation	37
	Eyepiece magnifier	38
	LEVELING ROD	39
	EYECUP HEATER + CABLE	40
	Filter wheel	41
	ORIENTABLE VIEWFINDER	42
	Adjustment of the swivelling viewfinder	45
	Adjustment of the telescopic tube	46
	Swivelling the viewfinder tube	47
3	THE ACCESSORIES AND VIDEO FINDERS ELECTRONIC	
	MOVIELITE - LCD type	50
	Mounting the MOVIELITE	51
	Handling the MOVIELITE - LCD type	52
	SLIDE-IN MOVIELITE - Mask type	54
	Handling the MOVIELITE masks	55
	Accessory connector	58
	READOUT	59
	READOUT FOR ORIENTABLE VIEWFINDER	62
	REMOTE CONTROL BOX	64
	Viewfinder right side	66

RIGHT EYEPIECE	67
B/W VIDEO CAMERA	68
B/W VIDEO ASSIST MONITOR	69
COLOR VIDEO CAMERA	71
<i>Connecting of the video cameras</i>	73
NTSC CEI COLOR VIDEO CAMERA	74
CEI V COLOR CCD VIDEO PICK UP	77
MOVIECAM Sync Cable for CEI V	84
CEI V ACCESSORY	85
3.5" LCD COLOR VIDEO ASSIST MONITOR	86
2" LCD COLOR VIDEO ASSIST MONITOR	87
VIDEO VIEWFINDER	88
LIGHTWEIGHT B/W VIDEO VIEWFINDER	90

4

THE MAGAZINES

<i>Care and cleaning</i>	94
<i>Label holder</i>	95
<i>Magazine right side</i>	95
<i>Magazine latches</i>	96
LIGHTWEIGHT MAGAZINES	97
400/120 MAGAZINE FOR STEADICAM	100
<i>Core holder</i>	101
<i>Loading of the magazines</i>	103
LOOP PROTECTOR	106
<i>Manual footage indicator</i>	107
<i>Digital footage counter</i>	109
<i>Tightening wheels</i>	111
<i>Roller assembly</i>	112
<i>Cleaning of the light trap</i>	113

5

THE MAGAZINE ADAPTERS

TOP MOUNT ADAPTER	117
REAR MOUNT ADAPTER	122
CAMERA COVER CAP	126

6

THE CARRYING HANDLE AND HANDGRIPS

UPPER CARRYING HANDLE	130
AUXILIARY CARRYING HANDLE	131
SIDE CARRYING HANDLE	132
SIDE HANDLE FOR ORIENTABLE VIEWFINDER	133
ADDITIONAL SUPPORT	134
REAR CARRYING HANDLE	135
HANDLE FOR STEADICAM MAGAZINE	136
RIGHT HANDGRIP	137
RIGHT HANDGRIP EXTENSION	138
LEFT HANDGRIP	139
PADDED SHOULDER REST	140

7	THE INTERIOR OF THE COMPACT	
	<i>Interior of the camera</i>	144
	<i>Pitch adjustment control</i>	145
	GROUND GLASSES	146
	<i>Changing the ground glass</i>	147
	UPPER APERTURE PLATES / gate	149
	LOWER APERTURE PLATE	152
	<i>Pressure plate</i>	154
	<i>Mirror shutter</i>	155
	<i>Setting the shutter angle</i>	156
8	THE POWER SUPPLIES	
	POWER SUPPLY UNIT	160
	BATTERY BLOCK	162
	ADJUSTABLE VOLTAGE STABILIZER	164
9	THREADING FILM IN THE COMPACT	
	<i>Threading film in the camera</i>	168
	<i>Door lock</i>	176
	<i>Dust check knob</i>	177
10	THE ACCESSORY BOXES AND IRIS CONTROL	
	<i>Accessory plug</i>	180
	<i>Speed control and synchronization</i>	182
	SYNCOBOX	185
	STICK-IN MODULES	187
	UPDATED SYNCOBOX SOFTWARE	189
	MAINS SYNC ADAPTER	191
	<i>Speed control</i>	196
	SPEEDBOX	197
	IRIS CONTROL	199
	SPEEDBOX REMOTE CONTROL	204
AATON CODEBOX	205	
11	THE SUPPORT, FOLLOW FOCUS AND MATTE BOX	
	BASE PLATE	218
	LENS SUPPORT	219
	STUDIO FOLLOW FOCUS	221
	LIGHTWEIGHT FOLLOW FOCUS	224
	MATTE BOX	226
12	MISCELLANEOUS AND APPENDIX	
	ASSISTANT WORK LIGHT	232
	TOOLS	233
	DIRECTORS FINDER	234
	APPENDIX	
	CONNECTORS AND CABLES	238

Notes:

THE COMPACT-SYSTEM

Fig. 1a + 1b

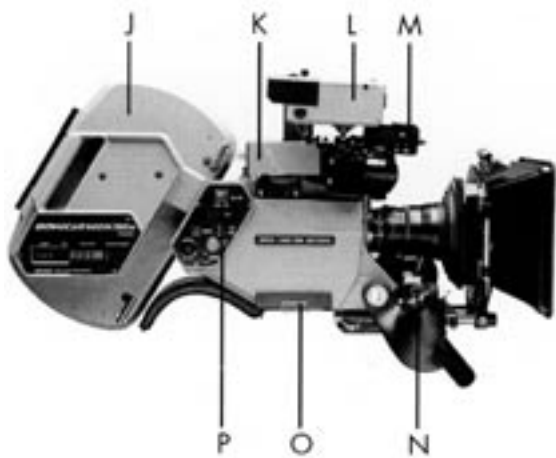

- A 1000 FT/300 M MAGAZINE
- B COLOR VIDEO ASSIST MONITOR
- C CARRYING HANDLE
- D MATTE BOX
- E FOLLOW FOCUS
- F SPEEDBOX
- G CONTROL BOARD
- H CCD COLOR VIDEO CAMERA
- I FOOTAGE COUNTER
- J 500 FT/150 M MAGAZINE
- K B&W VIDEO CAMERA
- L B&W VIDEO ASSIST MONITOR
- M READOUT
- N HANDGRIP ON/OFF BUTTON
- O ACCESSORY PLUG COVER
- P RIGHT SIDE ON/OFF BUTTON
- Q MOVIELITE
- R LONG EYEPiece
- S HEATED EYECUP
- T TOP MOUNT ADAPTER
- U LEFT SIDE ON/OFF BUTTON
- V BASE PLATE
- W SHORT EYEPiece
- X REAR MOUNT ADAPTER
- Y DUST CHECK BUTTON
- Z LEFT HANDGRIP

- A 1000 FT/300 M MAGAZINE
- B COLOR VIDEO ASSIST MONITOR
- C CARRYING HANDLE
- D MATTE BOX
- E FOLLOW FOCUS
- F SPEEDBOX
- G CONTROL BOARD
- H CCD COLOR VIDEO CAMERA
- I FOOTAGE COUNTER
- J 500 FT/150 M MAGAZINE
- K B&W VIDEO CAMERA
- L B&W VIDEO ASSIST MONITOR
- M READOUT
- N HANDGRIP ON/OFF BUTTON
- O ACCESSORY PLUG COVER
- P RIGHT SIDE ON/OFF BUTTON
- Q MOVIELITE
- R LONG EYEPIECE
- S HEATED EYECUP
- T TOP MOUNT ADAPTER
- U LEFT SIDE ON/OFF BUTTON
- V BASE PLATE
- W SHORT EYEPIECE
- X REAR MOUNT ADAPTER
- Y DUST CHECK BUTTON
- Z LEFT HANDGRIP

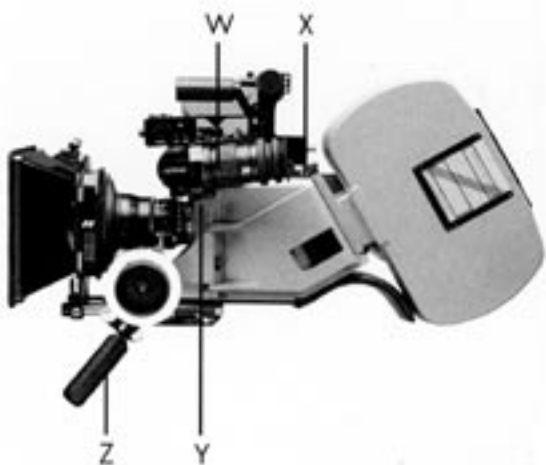
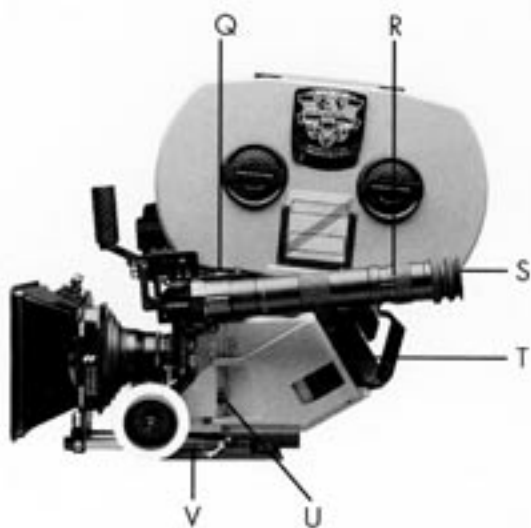

Notes:

CHAPTER 1

THE BODY OF THE COMPACT-SYSTEM

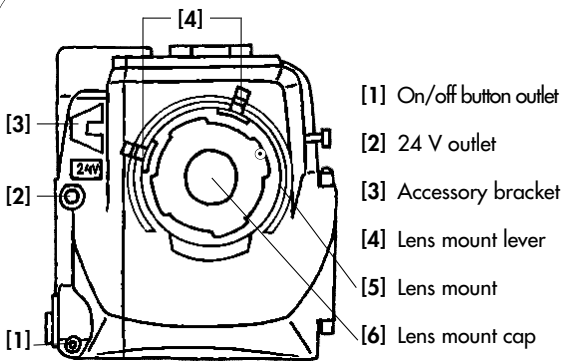

Fig. 2 – CAMERA FRONT

A lens mount [5] of either type ARRI PL or MITCHELL BNCR had been built into the camera front at the rental house. Depending on the mounting, you can shoot either **STANDARD 35** or **SUPER 35** format. To remove the mount cap [6] or the lens itself, turn the two bayonet levers [4] counter-clockwise. To mount a lens, turn the levers **gently** clockwise until the lens is seated properly. **Do not use force!**

Left of the lens mount there are two connectors. The top one [2] has a 24 V outlet, is protected by a 1,6 A multifuse and may be used for any remote-controlled device, e.g. zoom drive. In case of an external short circuit, e.g. defective zoom drive, the automatic multifuse cuts off the power supply of the connector. To reactivate the multifuse, remove the part that caused the short circuit; disconnect the camera for approx. 30 seconds, i.e. power supply has to be totally cut. The lower connector [1] may be used for the remote control of the **on/off button** (e.g. handgrip button).

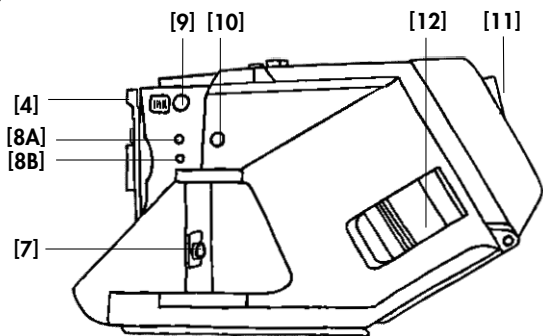

Fig. 3 – CAMERA LEFT SIDE

- [4] Lens mount levers
- [7] On/off button
- [8A] Connectors 24 V/400 mA
- [8B] Connectors 24 V/400 mA
- [9] Dust check knob
- [10] Indication of image plane/tape measure knob
- [11] Magazine-/top mount adapter connector
- [12] Door lock

The camera door is located at the left side. When it is closed, the door lock [12] must be flush with the door; a velcro attachment keeps the lock in this position. Power (24 V) for EYECUP HEATER and ASSISTANT WORK LIGHT is supplied via two connectors [8A] + [8B].

In case of an external short circuit, e.g. when EYECUP HEATER or ASSISTANT WORK LIGHT are defective, a 400 mA multifuse automatically cuts off the power supply of these connectors. To reactivate the multifuse, remove the part that caused the short circuit and disconnect the camera from its power supply for approx. 30 seconds.

The tape measure is attached to the hook **[10]** that indicates the image plane. By shortly pressing the **dust check knob [9]**, the mirror shutter is cleared out of the way and thus permits to check the film gate without having to open the camera door.

The camera is switched on by activating either the button **[7]** or some other **on/off buttons**, e.g. at the camera right side. Equally, any of those buttons can be employed to switch off the camera, and vice versa.

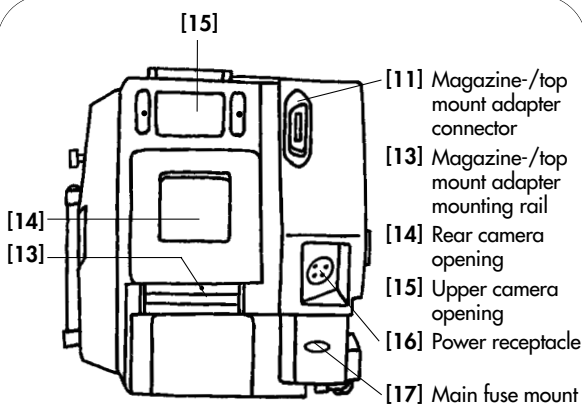

Fig. 4 – CAMERA REAR

The MAGAZINES can be attached to either opening **[14]** or **[15]** at the camera rear resp. top by mounting them (or MAGAZINE ADAPTER) to the mounting rail **[13]**.

The connector **[11]**, mounted mobile to facilitate the plug-in, is used for both electronic interface and power supply for the magazine drives.

Below the magazine connector there is the receptacle **[16]** for the camera's 24 V power supply. Turn fuse holder **[17]** clockwise to remove it and exchange the glass fuse 5 x 20mm (6,3 A / slow), if necessary.

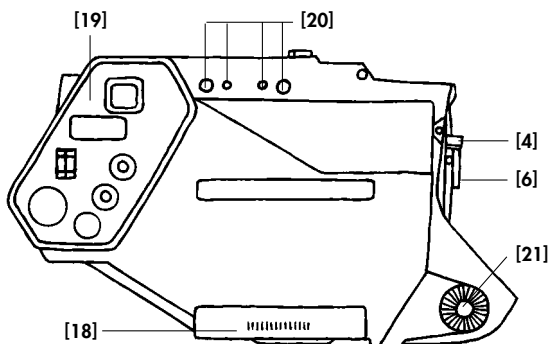

Fig. 5 – CAMERA RIGHT SIDE

- [4] Lens mount lever
- [6] Lens mount cap
- [18] Cover plate for accessory box plug
- [19] Control board and displays
- [20] Top carrying handle attachment (threaded sockets + gauged boreholes)
- [21] Right handgrip rosette

The *UPPER CARRYING HANDLE* is attached to the threaded sockets and gauged boreholes **[20]** on top of the camera right side; the *RIGHT HANDGRIP* is screwed into the threaded socket in the rosette center **[21]**.

Below the cover plate **[18]** there is the plug for the *ACCESSORY BOXES*.

A plexi-glass panel covers the control board and display **[19]** (see page 21 - 23).

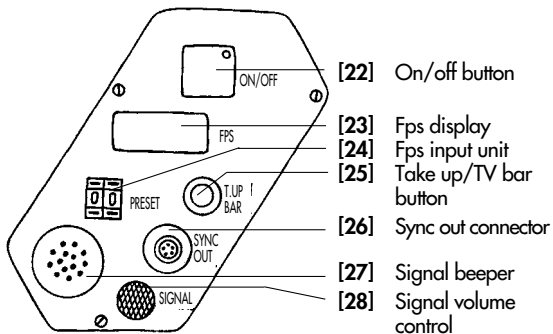

Fig. 6 – CONTROL BOARD

The acoustic signal beeps shortly when the COMPACT has reached the preset frame speed (after starting up), is switched off or its actual speed differs from the preset one.

Fig. 7 – DISPLAY

Following information is provided by the display on the control board of the MOVIECAM COMPACT, on the READOUT or on the REMOTE CONTROL BOX

MOVIECAM COMPACT without ACCESSORY BOX:

B

Flashing when a buckle switch has been interrupted (e.g. badly threaded film), or the rear buckle switch is not in stand-by position.

0

Stand-by camera.

12

Lighting when camera runs with 12 fps. Flashing when lower speed has been selected.

24

Lighting when camera runs with 24 fps.

32

Lighting when camera runs with 32 fps. Flashing when a higher speed has been selected.

DC

Flashing when dust check knob is pressed and mirror shutter is in shooting position.

12V

Blinks for about four sec. when the COMPACT is powered up while a defective video accessory (e.g. monitor, transmitter) is connected to the video assist.

– MOVIECAM COMPACT with SPEEDBOX:

MSP

Flashing when speed either too high or low has been selected on speed box.

2

Lighting when camera runs with 2 fps. Flashing when lower speed has been selected.

50

Lighting when camera runs with 50 fps. Flashing when higher speed has been selected.

- 12

Reverse shooting with 12 fps. Flashing when lower reverse speed has been selected.

- 24

Reverse shooting with 24 fps.

- 32

Reverse shooting with 32 fps. Flashing when higher reverse speed has been selected.

SFR

Shown when mirror shutter, controlled via single frame connector, remains in shooting position (approx. 4 seconds).

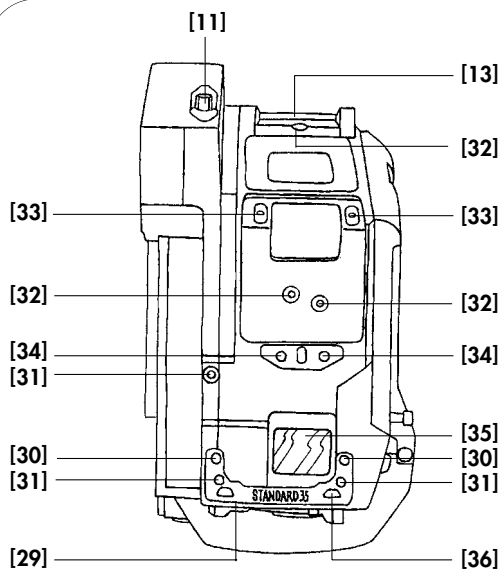

Fig. 8 – CAMERA TOP

- | | |
|--|---|
| [11] magazine-/top mount adapter connector | [32] adjusting screws (for rental house only!) |
| [13] magazine-/top mount adapter mounting rail | [33] rear mount adapter attachment (threaded sockets) |
| [29] engraved viewfinder mounting plate | [34] rear and top mount adapter attachment (threaded sockets) |
| [30] viewfinder attachment (gauged boreholes) | [35] glass surface (viewfinder) |
| [31] viewfinder attachment (threaded sockets) | [36] viewfinder connector |

Caution: Do not touch the adjusting screws [32] – they are reserved for the technicians of the rental house only!

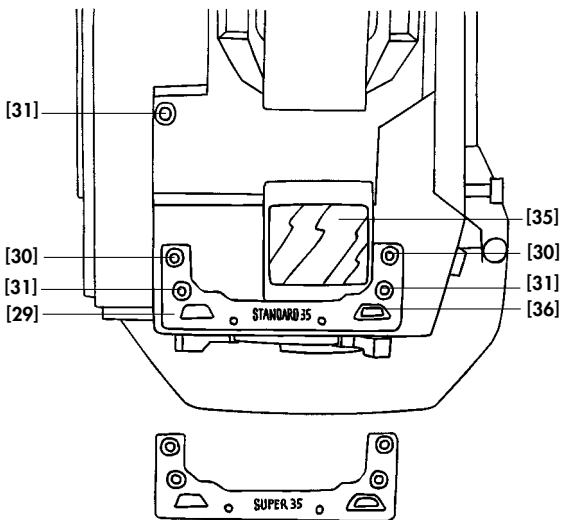

Fig. 9 – VIEWFINDER MOUNT PLATE

The plate on top of the CAMERA BODY shows the format the camera has been adjusted to (either STANDARD 35 or SUPER 35 format).

The engraved viewfinder mounting plate [29] is turned upside down when changing the format at a rental house. The viewfinder systems are attached to the gauged boreholes [30] and threaded sockets [31] and flanged to the plate [29] on top of the glass surface [35].

The REAR MOUNT ADAPTER is attached to the threaded sockets [33] and [34], the TOP MOUNT ADAPTER only to the front threaded sockets [34].

Caution: The format should be changed at a rental house only! The lens mount and – by turning the mount plate upside down – also the viewfinder mount will be adjusted. Now, the engraving indicates the new format.

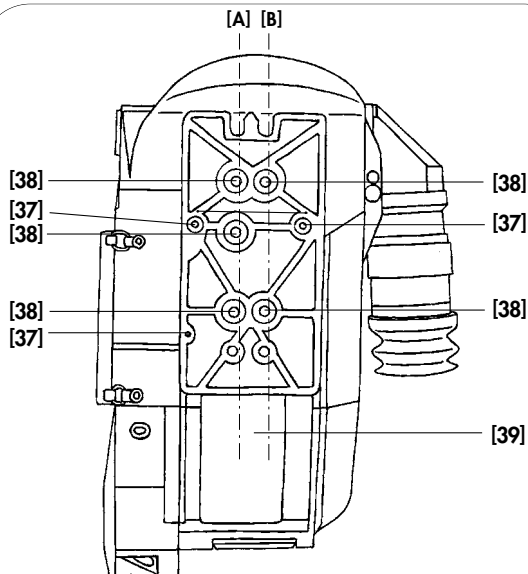

Fig. 10 – CAMERA BASE

- [A] ARRI axis
- [B] MOVIECAM axis
- [37] Adjusting screws **(for the rental house only!)**
- [38] Threaded sockets
- [39] Velcro attachment for shoulder rest

The COMPACT has a dual axis base. The axis **[A]** is ARRI standard, the axis **[B]** MOVIECAM standard. Accessory may thus be interchanged between both systems.

A PADDED SHOULDER REST can be attached to the black velcro adhesive strip **[39]**.

Caution: Do not touch the adjusting screws [37] – they are reserved for the technicians of the rental house only!

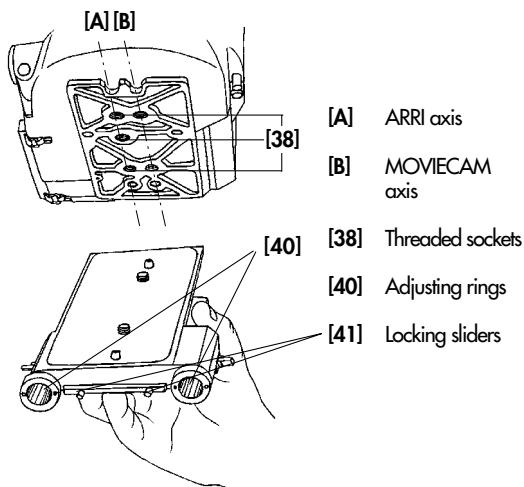

Fig. 11 – BASE PLATE

SUPPORT RODS and, subsequently, LENS SUPPORT, MATTE BOX, STUDIO FOLLOW FOCUS etc. are attached to the BASE PLATE. You will not need the PLATE when using PRIME LENSES, flanged FILTER HOLDERS, SUNSHADES and LIGHTWEIGHT FOLLOW FOCUS. Depending on the accessories, screw the BASE PLATE into either the left ARRI axis [A] or the right MOVIECAM axis [B] with a wide screwdriver.

Caution:

In case no original MOVIECAM base plate is used, do not screw the attaching screws further than 7 mm into the threaded sockets of the camera base. Longer screws may damage the camera. When attaching the base plate, care should be taken that it sits flat on the camera base.

The support rod brackets on the MOVIECAM BASE PLATE are mobile. This is of advantage when shifting the optical axes for shooting in either **STANDARD 35** or **SUPER 35** format.

The rod brackets can be adjusted to either format by turning the asymmetrical rings **[40]**. Just press both sliders **[41]** toward the center and turn the rings so that each two dots of the same color face the center and the locating pins engage in the holes (see also page 216).

White = **STANDARD 35** format

Red = **SUPER 35** format

Notes:

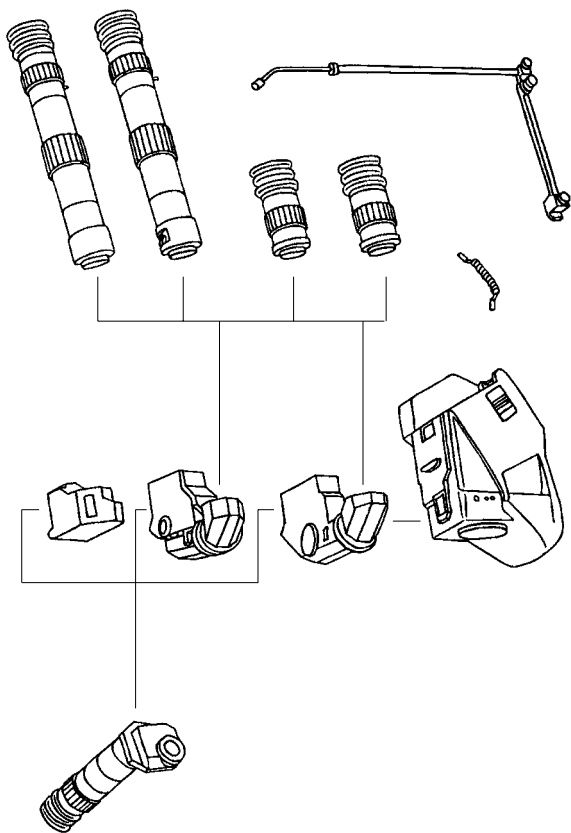

CHAPTER 2 THE OPTICAL VIEWFINDERS

CHAPTER 2

THE OPTICAL VIEWFINDERS

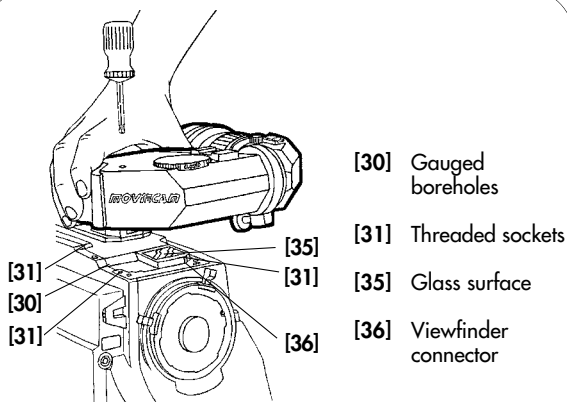

Fig. 12 – THE STANDARD VIEWFINDER

Various viewfinders may be used with the MOVIECAM COMPACT modular system:

- A) STANDARD VIEWFINDER
- B) VIDEO VIEWFINDER
- C) LIGHTWEIGHT B&W VIDEO VIEWFINDER
- D) ORIENTABLE VIEWFINDER

The STANDARD VIEWFINDER permits the use of EYEPIECE (mounted to the left) and VIDEO CAMERA (mounted to the right side) at the same time. Light transmission depends on the built-in beamsplitter. The basic equipment is a beamsplitter 80%/20% (80% light transmission for the eyepiece, 20% for the video camera). A beamsplitter 50%/50% may be built in at your rental house.

After removing both caps, the STANDARD VIEWFINDER is mounted to the CAMERA BODY with three M5 Allen screws. Care should be taken that:

1. the VIEWFINDER sits plane on the mount,
2. the pins engage easily in the gauged boreholes and
3. both glass surfaces are absolutely clean.

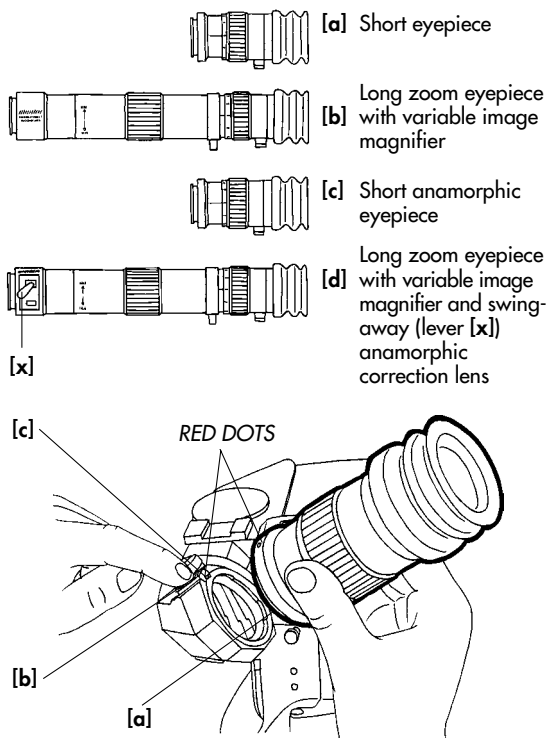

Fig. 13/14 – THE EYEPIECES

The four EYEPIECES have bayonet mounts **[a]**. The rippled black slider **[b]** on top of the mobile eyepiece mount unlocks the bayonet.

When the red dots of both eyepiece and mount line up, mount the eyepiece by turning it clockwise until the locating pin **[c]** engages with an audible click.

Care should be taken that glass surfaces and bayonet mounts are absolutely free from dust!

To remove the EYEPIECE, move the slider **[b]** backward and turn the EYEPIECE counter-clockwise.

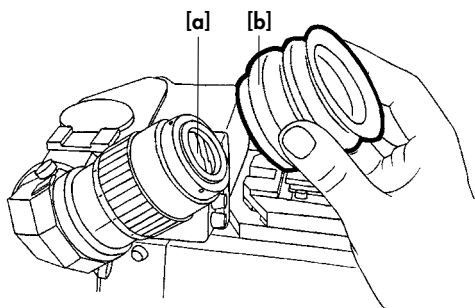

Fig. 15 – THE EYECUP

Each EYEPIECE has an interchangeable rubber eyecup **[b]**. To clean the exit pupil **[a]**, remove the eyecup by simply pulling it straight out.

Eye-friendly covers, such as chamois or cotton cloth, can be easily attached with a rubber band. Another useful cover are the terry cloth "wrist bands", well-known from tennis, as they are sweat-absorbing, reusable and easy to attach.

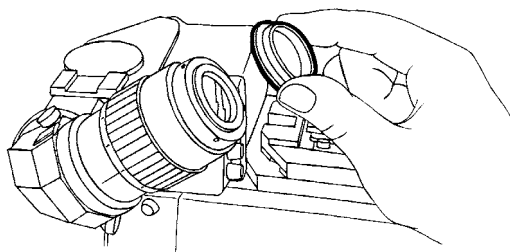

Fig. 16 – EYEPIECE RETAINING MOUNT

Below the rubber eyecup there is a magnetically held attachment ring for a diopter correction lens or some special filter.

Lens or filter, which can be supplied by your rental house, must have a diameter of 31,5mm.

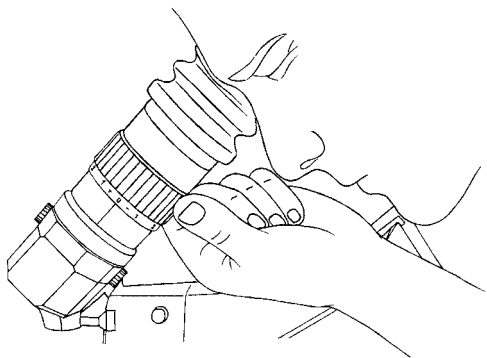

Fig. 17 – DIOPTR CORRECTIONS

Each MOVIECAM EYEPIECE may be diopter-adjusted by turning the knurled barrel.

With the help of a scale, where personal marks may be added, the assistant can easily adjust the lens to the eyesights of the different people using the camera. Corrections can be made from -5 to $+5$ diopters.

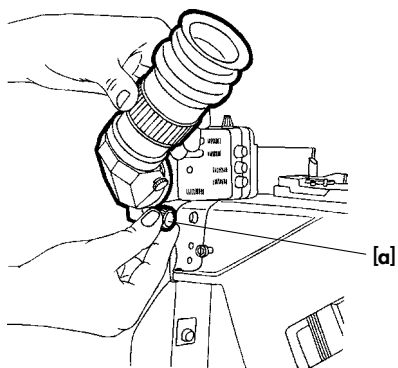

Fig. 18 – FRICTION ADJUSTMENT

Each EYEPIECE mounted to the left side of the viewfinder rotates vertically 360° . To turn the EYEPIECE, loosen the **tension screw [a]** below the eyepiece mount, turn the EYEPIECE and tighten the screw again.

Although this friction brake can hold the weight of a long EYEPIECE, it is recommended to attach the LEVELING ROD.

Caution: The tension brake must be loose when using the leveling rod (see page 39)!

To **loosen** tension brake, turn counter-clockwise.
To **tighten** tension brake, turn clockwise.

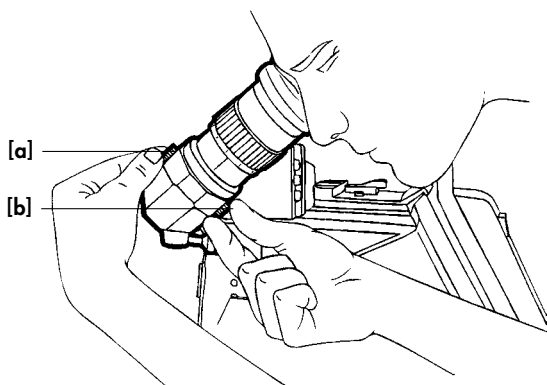

Fig. 19 – ERECT IMAGE VIEWFINDER

The eyepiece mount, integrated into the STANDARD VIEWFINDER and rotatable by 360° , automatically gives an upright erect image, regardless of the angle of view.

When changing from a short to a LONG EYEPIECE and vice versa, however, you have to adjust the image orientation manually by turning the prism assembly 180° .

In case a different image orientation is desired, you can turn it as you like.

At the bottom as well as on top of the eyepiece mount, there is a **knurled adjusting screw**. Loosen the screw at the bottom **[b]** while holding the one on top **[a]**; then turn the upper screw until you get the image desired. To fix the new position, tighten the screw at the bottom again while holding the one on top.

There are positive stops at the angles 0° , 90° , 180° and 270° so that the standard positions easily click into place.

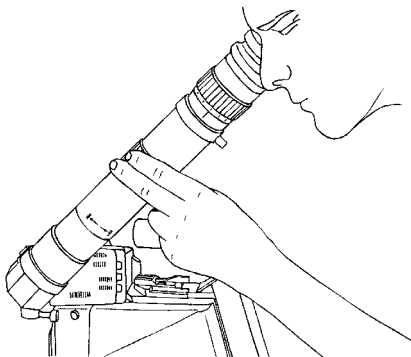

Fig. 20 – EYEPIECE MAGNIFIER

Both LONG EYEPIECES have built-in magnifiers that allow even more critical eye-focusing. Turn the **zoom ring** to magnify the image on the ground glass in a continuous range. A mark on the ring indicates the regular image size.

Caution: It is recommended to use the zoom only when checking and not when shooting as only the center part of the image appears in the eyepiece.

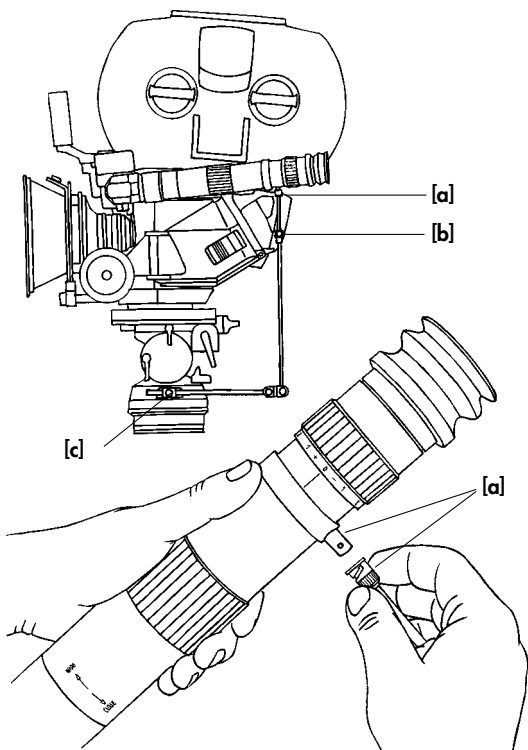

Fig. 21 – LEVELING ROD

A viewfinder support *LEVELING ROD* may be attached to the *LONG EYEPIECES*. This rod is attached or removed like a *BNC video connector* [a].

The support is clamped to the head [c]. Its length is variable [b].

Caution: When working with the leveling rod, the friction brake must be loose (see page 36)!

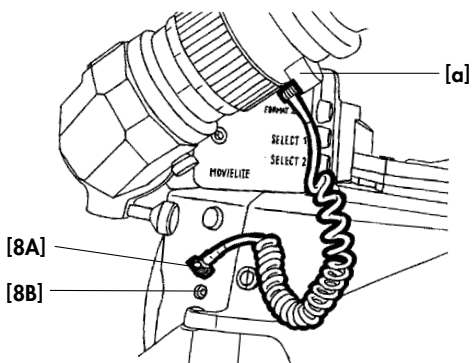

Fig. 22 – EYECUP HEATER

Heated eyecups, which eliminate fogging of the exit pupil, are integrated in the five EYEPIECES of the MOVIECAM COMPACT.

There is no **on/off switch** for the eyecup heater; in order to activate it, disconnect the camera, plug one end of the *SHORT COILED CABLE* into the eyepiece connector **[a]**, the other end into one of the two connectors **[8A]** or **[8B]** (see page 17).

Connectors on *CAMERA* and *EYEPIECE* are identical.

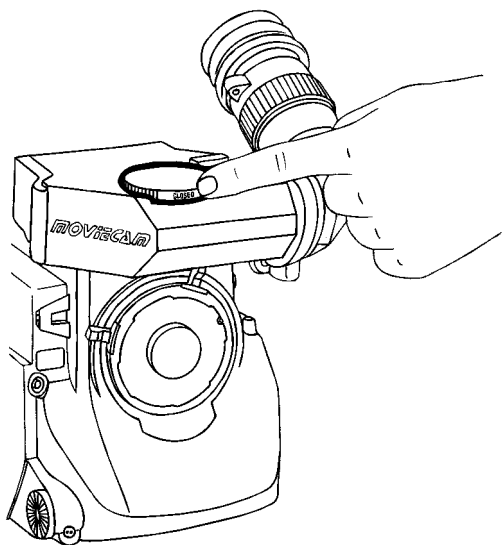

Fig. 23 – FILTER WHEEL

The filter wheel integrated in the STANDARD VIEWFINDER can be set to three different positions:

- 1) **OPEN**
- 2) **FILTER** (ND 06)
- 3) **CLOSE**

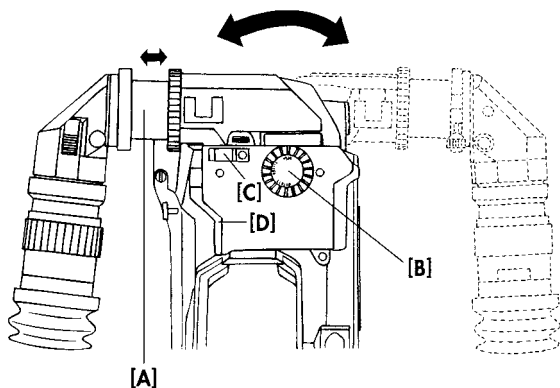

Fig. 24 – ORIENTABLE VIEWFINDER

Contrary to the STANDARD VIEWFINDER, the ORIENTABLE VIEWFINDER can be pivoted to the right and left; it is also more ergonomical.

The ORIENTABLE VIEWFINDER allows a comfortable view into the camera from right as well as from left, either with the right or the left eye.

The four EYEPIECES known from the MOVIECAM viewfinder system can be used on the new ORIENTABLE VIEWFINDER: the Short Eyepiece, the Long Eyepiece with Image Magnifier, the Short Anamorphic Eyepiece and the Long Eyepiece with Image Magnifier and Swing – Away Anamorphic Correction Lens.

The B&W- or the Color Video Cameras of the COMPACT CAMERA SYSTEM can be attached to the ORIENTABLE VIEWFINDER as well.

An axial shifting of the entrance pupil with the help of the telescope **[A]** of the VIEWFINDER allows for an optimum adjustment of the COMPACT to the user's visual field. Shifting does not change size, sharpness or quality of the viewfinder image.

Functions and possibilities of the new viewfinder block are identical with those of the STANDARD VIEWFINDER; these are the FILTER WHEEL **[B]**, a (new) READOUT, mounting **[C]** of a REMOTE CONTROL and **[D]** of the MOVIELITE.

As long as you look into the viewfinder from behind the camera, the image orientation does not change, even when the EYEPIECE has been pivoted to the right side of the camera!

In case you want to look into the eyepiece from the camera front side, the image orientation has to be adjusted with two knorled adjusting screws – see page 37.

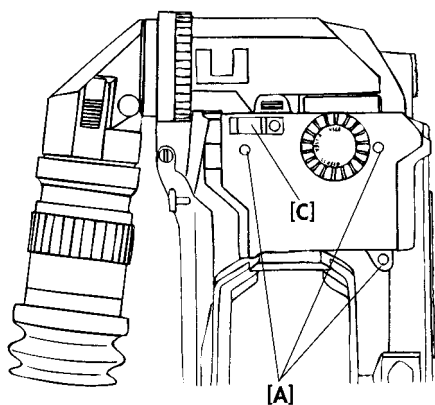

Fig. 25 – ORIENTABLE VIEWFINDER

Like the other viewfinder blocks, the ORIENTABLE VIEWFINDER is mounted to the top of the camera body with three screws [A]. The connector for the REMOTE CONTROL [C] has been modified. Should you receive a REMOTE CONTROL from a rental house, make sure the connecting cable is equipped with the new plug.

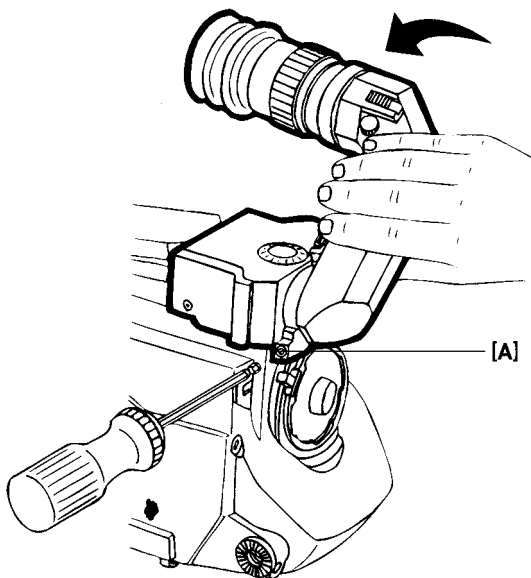

Fig. 26 – ORIENTABLE VIEWFINDER

With the M5 Allen screw **[A]** at the right bottom of the ORIENTABLE VIEWFINDER; the torque of the left/right swivelling mechanism can be adjusted.

It is recommended to adjust the friction so that it is comfortable for the user.

In order to minimize the leverage on the viewfinder, loosen the friction before you pivot the eyepiece from one side of the camera to the other.

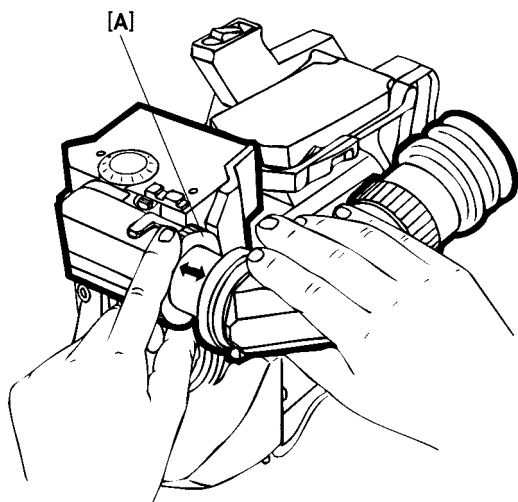

Fig. 27 – ORIENTABLE VIEWFINDER

The knorled ring **[A]** helps to loosen or fix the telescopic viewfinder tube. This tube can be moved 26mm (1.02 inch) to the inside or outside in order to achieve the ergonomically best point of view. The ring is fixed by turning clockwise and loosened by turning counter-clockwise. The offset pivoting of the eyepiece has no influence on size or quality of the viewfinder image.

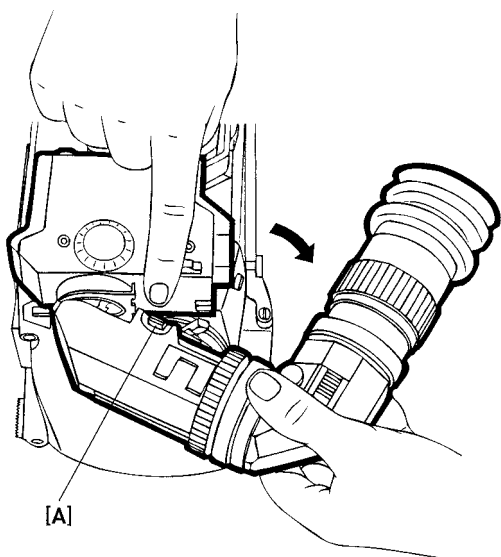
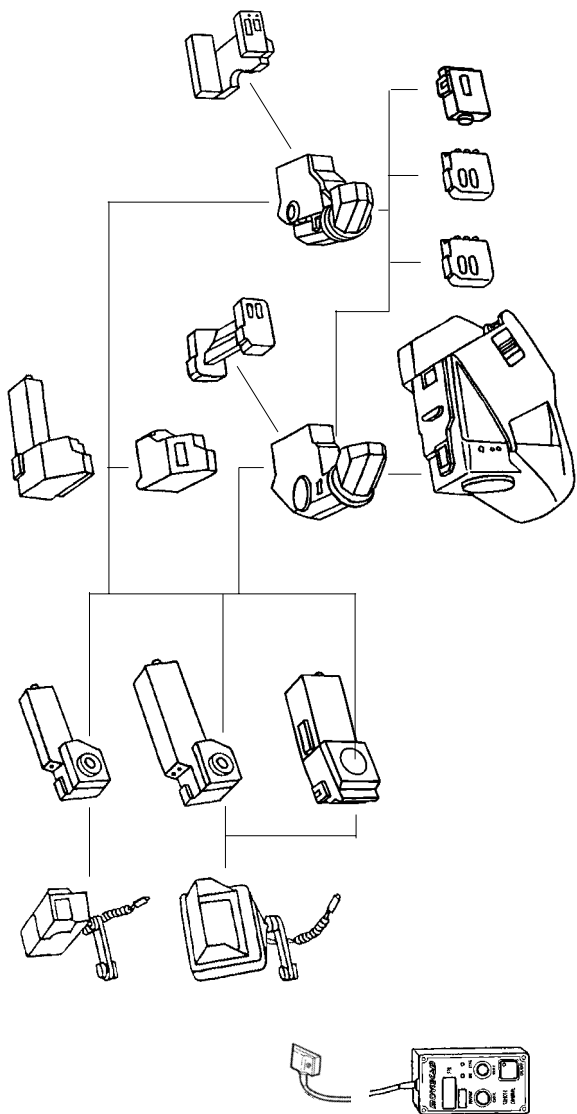

Fig. 28 – ORIENTABLE VIEWFINDER

Only when the 1000 ft magazine is mounted with a TOPLOAD ADAPTER should the ORIENTABLE VIEWFINDER be tilted forward in order to be able to swing the EYEPIECE to the other side of the camera. To do so, loosen the friction screw (Fig. 26) first. Then press the button **[A]** and swing the viewfinder cautiously forward. After pivoting the EYEPIECE to the other side of the camera, close the viewfinder block again; it locks automatically.

- Caution:**
- 1) No dirt must get into the open viewfinder system!**
 - 2) With well maintained cameras, pivoting is easily possible without having to apply force.**



CHAPTER 3 THE ACCESSORIES AND VIDEO FINDERS

CHAPTER 3

THE ACCESSORIES AND VIDEO FINDERS

THE MOVIELITE

Additionally, various accessories may be attached to the standard viewfinder:

- A) MOVIELITE
- B) READOUT
- C) REMOTE CONTROL

The MOVIELITE **[a]** (see page 51) fades in luminous frames. This facilitates the operator's job, especially under low light conditions. Due to the various sizes (aspect ratios and formats), MOVIECAM offers two different MOVIELITES. The only visible difference between the two MOVIELITES, however, is a small "S", engraved next to the serial number of the MOVIELITE.

without engraving = **STANDARD 35**

with engraved "S" = **SUPER 35**

The MOVIELITE fades in one or – simultaneously – two luminous frames. Four resp. five frames with the following aspect ratios are provided in the two MOVIELITES:

Standard	"S"
TV	TV
1 : 1,375	1 : 1,33 full
1 : 1,66	1 : 1,85 S
1 : 1,85	1 : 2,35 S 35 scope
1 : 2,35 scope	

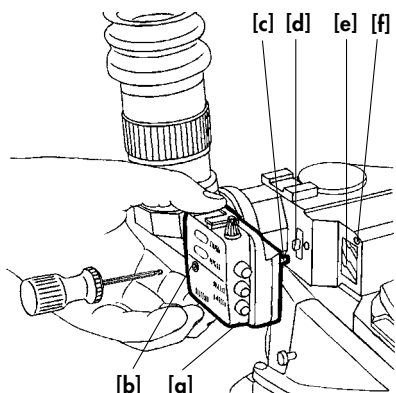

Fig. 29 – MOUNTING THE MOVIELITE

After removing both caps, attach the MOVIELITE to the VIEWFINDER with one M5 Allen screw **[b]**.

Care should be taken that:

1. the camera is disconnected (also when removing the MOVIELITE),
2. the MOVIELITE sits plane on the VIEWFINDER,
3. the pin **[c]** engages easily in the gauged borehole **[f]** and the connectors **[d]** are properly seated,
4. both glass surfaces **[e]** are absolutely clean.

Caution: Only with identical serial numbers on camera, viewfinder and movielite can the manufacturer guarantee an exact correspondence of groundglass mark and luminous frame.

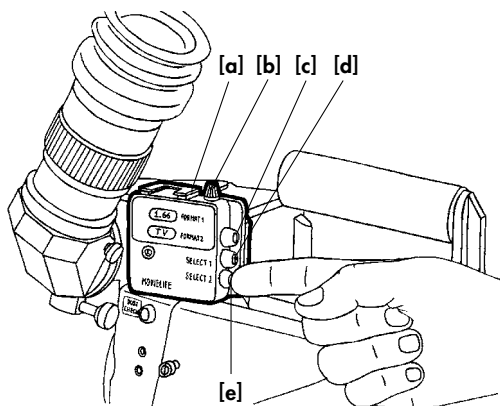

Fig. 30 – HANDLING OF THE MOVIELITE

- | | | | |
|-----|---------------------------|-----|----------|
| [a] | Accessory bracket | [d] | Select 1 |
| [b] | Dimmer | [e] | Select 2 |
| [c] | On/off button for reticle | | |

By gently pressing the button “Select 1”, a luminous frame appears on the ground glass.

The display “Format 1” shows the aspect ratio.

By pressing the button “Select 1” again, the other aspect ratios will be displayed.

In case a frame, e.g. $1 : 1,66$, is already faded in and you want to add another one, e.g. TV , just press the button “Select 2” until the desired aspect ratio appears in the display “Format 2”.

Each of the frames mentioned above may be switched on/off with either of the two “Select” buttons. The MOVIELITE memory stores the latest setup chosen, even when the camera is disconnected.

A luminous reticle can be switched on/off with button [c].

The brightness of the two luminous frames and the reticle may be continuously adjusted with the potentiometer [b] (see warning on page 69).

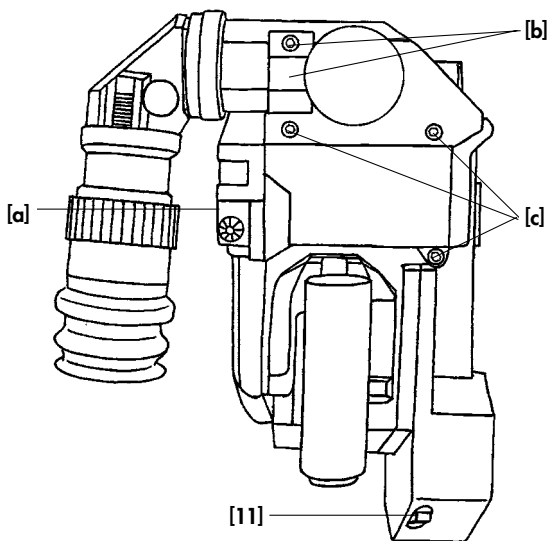

Fig. 31 – MOVIELITE

- [a] Movielite
- [b] Connector cover plate and screw
- [c] Viewfinder retension screws
- [11] Magazine-/top mount adapter connector

The MOVIELITE and the viewfinder retension screws can easily be seen from the top.

The small cover plate [b], attached with one M5 Allen screw, protects the connector for further accessories READOUT and REMOTE CONTROL BOX.

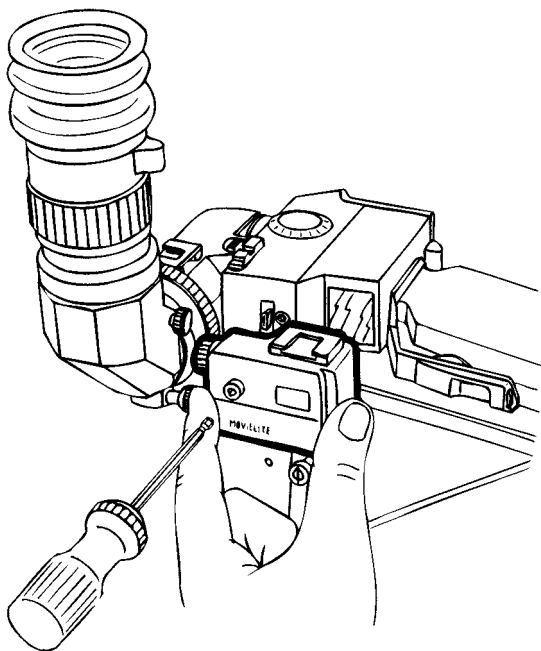

Fig. 32 – SLIDE-IN MOVIELITE

*In order to satisfy special customer requests regarding the ground glass marks with faded-in luminous frames, another MOVIELITE has been developed. Like the electronic type, the new MOVIELITE is mounted with an M5 Allen screw after removal of the protecting caps. The formats to be faded in are not chosen electronically but with the use of slides. Customer specific format combinations that are not offered as "Standard Slides" or in the electronic MOVIELITE can be produced by MOVIECAM on order. The slides of the new MOVIELITE can be used with the MOVIECAM **(but not the Mk2!)** as well.*

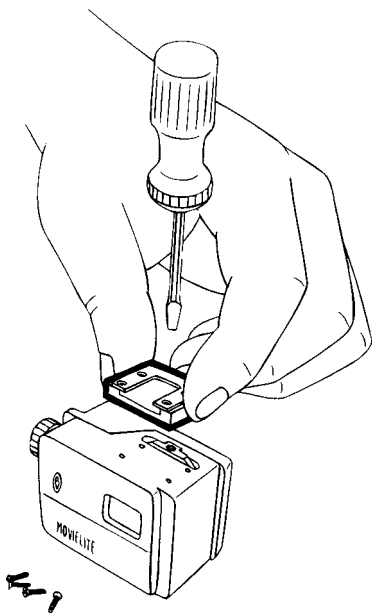

Fig. 33 – SLIDE-IN MOVIELITE

The slides are mounted on top of the new MOVIELITE, below the accessory bracket, in the opening.

Caution: *When removing the accessory plug, everything must be extremely clean; no dirt must get into the opening. Take care not to lose the four screws.*

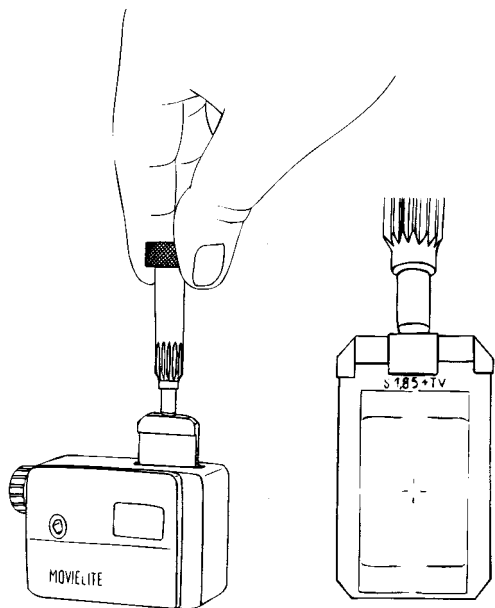

Fig. 34 – SLIDE-IN MOVIE LITE

The slide is mounted and removed with the COMBITOOL.

When mounting the slide, care must be taken that it is inserted until it touches the buffer.

Below the removed accessory bracket is a strip of elastic material which fixes the slide in its position.

Caution: Care must be taken as the slide is sensible to scratches.

The rental houses offer a large variety of various formats and format combinations, such as [Super 35/ 1:1/ 85 & TV]. When collecting the equipment, care should be taken that the right slide (suitable to the ground glass) is available.

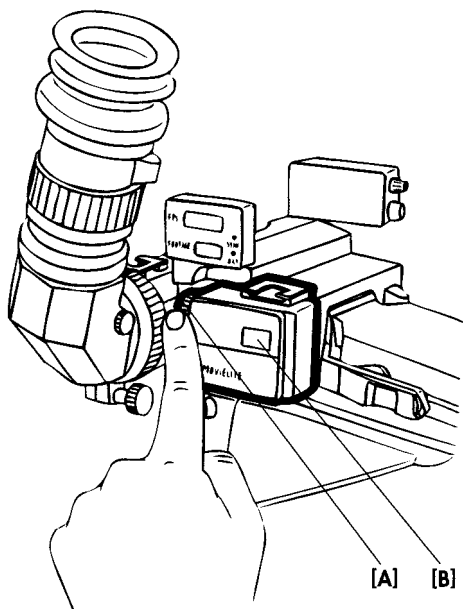

Fig. 35 – SLIDE-IN MOVIELITE

The MOVIELITE is activated with the rotary knob **[A]**. This knob, which is no on/ off switch, is a dimmer that changes the brightness of the luminous frames from light to extinguished. In the small window **[B]** the slide marks can be read and the brightness checked (see warning on page 69).

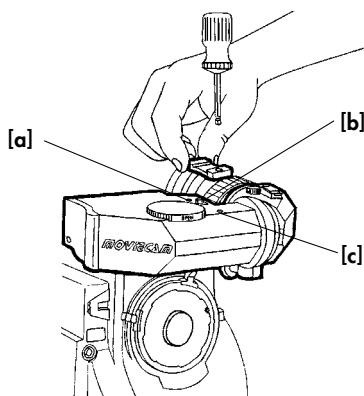

Fig. 36 – ACCESSORY CONNECTOR

- [a] Gauged borehole
- [b] Connector
- [c] Threaded socket

On top of the *STANDARD VIEWFINDER* there is a connector **[b]** for the two accessories *READOUT* and *REMOTE CONTROL BOX*.

Remove the small cover plate that protects the connector by unscrewing the M5 Allen screw and attach the accessory.

- [a] Gauged borehole
- [b] Connector
- [c] Threaded socket

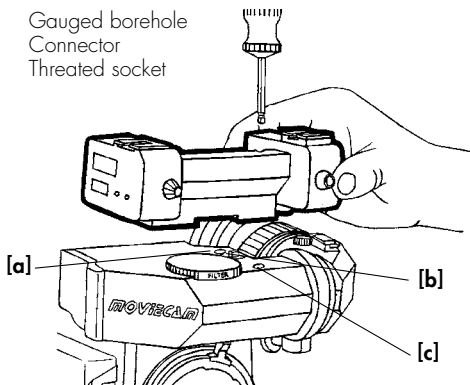

Fig. 37/38 – READOUT

The READOUT displays exposed footage, frame speed, battery condition, syncspeed and warning signs.

On top of the displays there are accessory brackets for mounting e.g. the ASSISTANT WORK LIGHT.

After removing the small cover plate (see fig. 31 [b]) and disconnecting the camera, screw the READOUT onto the VIEWFINDER with an M5 Allen screw. Care should be taken that the pin and the connector [b] engage easily. Even with the attached READOUT the filter wheel can be easily operated.

- [d] Accessory bracket

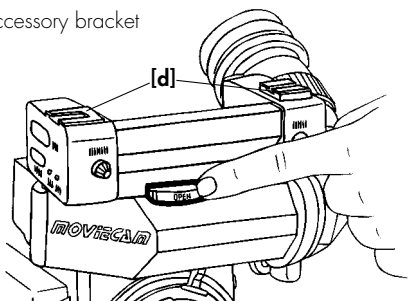

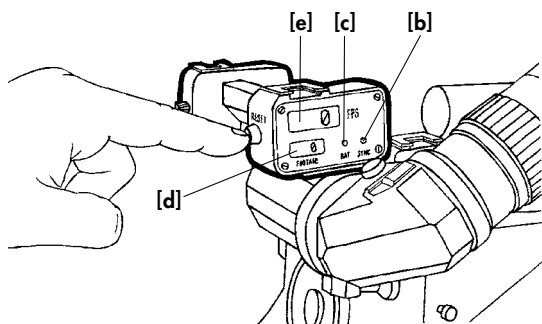

Fig. 39 – READOUT

The READOUT is powered directly from the camera. The last indicated footage remains stored even when the camera is disconnected.

*When the camera is plugged in, reset the footage counter to by pushing the **reset button**.*

To change measure unit (m/ft), contact your rental house.

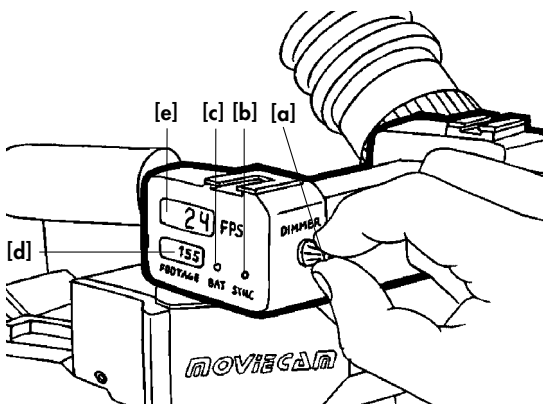

Fig. 40 – READOUT

The digital displays are easily readable from both camera sides. Their brightness can be adjusted with a **dimmer [a]**. The footage counter light **[d]** glows whenever proper voltage is connected; the red diode **batt [c]** lights up in case of a substantial voltage drop and fades again when the camera is sufficiently powered.

The frame speed, e.g. 24 fps, is displayed **[e]** when switching on the camera. In case the actual frame speed of the camera differs from the preset speed, the red diode **sync [b]** lights up; this diode remains also lit as long as the camera runs up to speed.

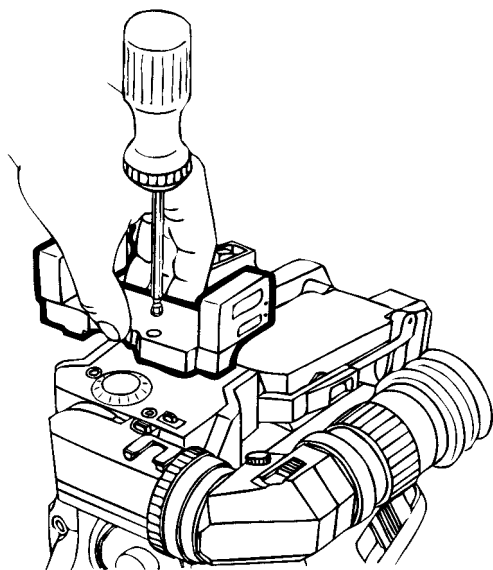

Fig. 41 – READOUT

A new READOUT that allows pivoting of the viewfinder has been developed especially for the ORIENTABLE VIEWFINDER.

Its functions are identical with those of the present READOUT of the COMPACT CAMERA SYSTEM. The new READOUT is attached to the ORIENTABLE VIEWFINDER with an M5 Allen screw.

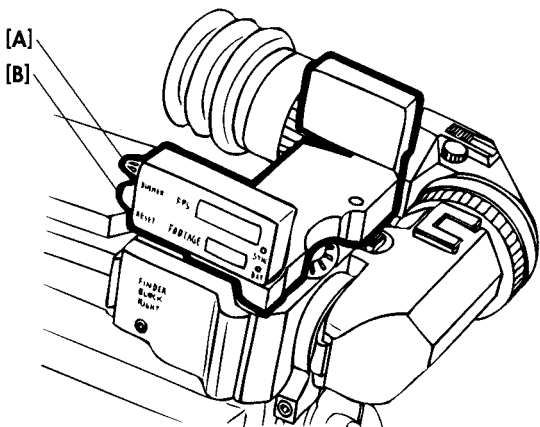

Fig. 42 – READOUT

On the new READOUT, the dimmer (knob) **[A]** and the reset button **[B]** are located on the right side. The READOUT displays are identical with those of the other READOUT; see page 60 + 61.

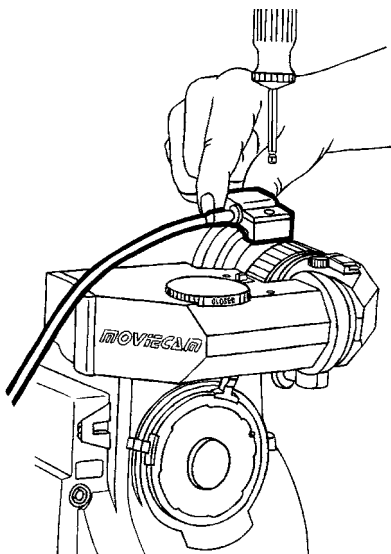

Fig. 43 – REMOTE CONTROL BOX

Similar to the READOUT, the small connector of the REMOTE CONTROL BOX is attached to the STANDARD VIEWFINDER with one M5 Allen screw. You can only mount either REMOTE CONTROL BOX or READOUT.

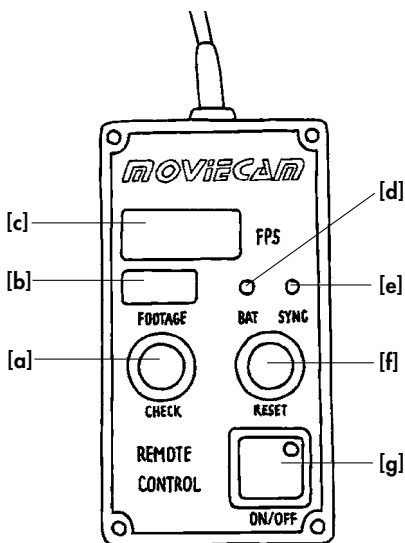

Fig. 44 – REMOTE CONTROL BOX

The REMOTE CONTROL BOX of the MOVIECAM COMPACT works as both on/off switch and "remote" READOUT. You can read exposed footage **[b]**, frame speed **[c]**, battery condition **[d]**, sync speed **[e]** and warning signs up to a distance of 10 m. As long as the REMOTE CONTROL BOX is connected to the ready-to-shoot camera, the footage counter is on. It can be reset to by pushing the reset button **[f]**. By pressing the check-button **[a]**, the preset frame speed or a warning sign appears on the fps-display **[c]**. The fps display lights up when you switch on (button **[g]**) the camera.

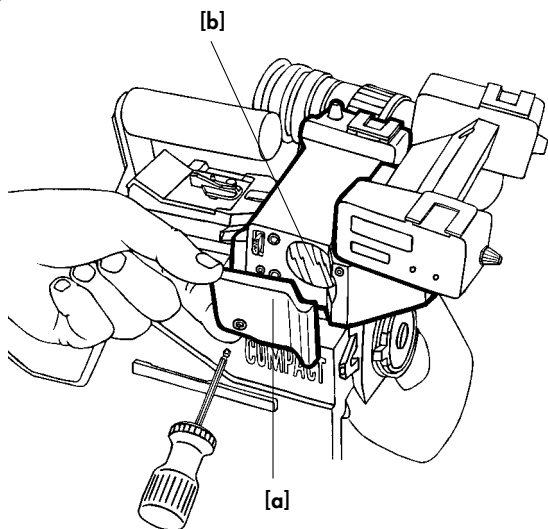

Fig. 45 – VIEWFINDER RIGHT SIDE

At the right side of the STANDARD VIEWFINDER, below a cover **[a]**, there is the exit pupil **[b]** for the video image. Always attach the cover to the viewfinder (with one M5 Allen screw) when no VIDEO CAMERA or RIGHT EYEPIECE is installed.

Two VIDEO CAMERAS can be attached to the STANDARD VIEWFINDER right side - either a B&W CAMERA or a COLOR CAMERA.

Each of those cameras has a BNC video outlet, an attachment and a connector for a small on-board VIDEO ASSIST MONITOR.

For right side viewing, the RIGHT EYEPIECE can be mounted instead of the VIDEO CAMERA.

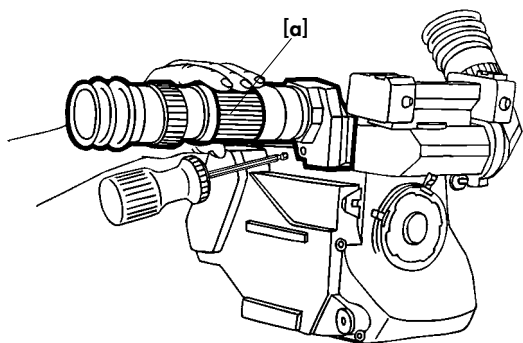

Fig. 46 – RIGHT EYEPIECE

In situations when it is not possible or too dangerous to use the LEFT EYEPIECE, you can mount the RIGHT EYEPIECE to the right side of the STANDARD or VIDEO VIEWFINDER (see page 74) with one M5 Allen screw.

Eyecup, diopter setting and eyecup heater of this RIGHT EYEPIECE are identical with those of the four other EYEPIECES.

As this RIGHT EYEPIECE does not automatically give an upright erect image, you have to adjust the image by manually turning the knurled barrel [a].

Caution:

- ***Due to the beamsplitter in the standard viewfinder (80%/20%), the image in the right eyepiece appears to be darker than that in the left.***
- ***No video assist may be used while the right eyepiece is mounted.***

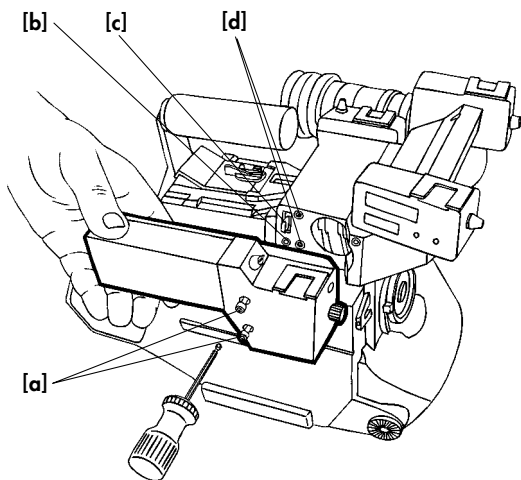

Fig. 47 – THE B&W VIDEO CAMERA

- [a] Allen screws
- [b] Gauged borehole
- [c] Video camera connector
- [d] Threaded sockets

*Disconnect the MOVIECAM COMPACT and mount the B&W VIDEO CAMERA to the right side of the STANDARD VIEWFINDER with two M5 Allen screws **[a]**.*

Take care that locating pins and connector pins engage easily. Optical elements have to be absolutely clean.

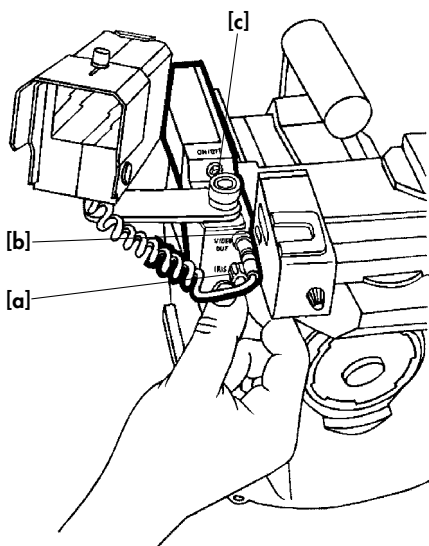

Fig. 48 – B&W VIDEO CAMERA AND B&W VIDEO ASSIST MONITOR

Mount the small B&W VIDEO ASSIST MONITOR by sliding its rotatable arm onto the accessory brackets on top of the VIDEO CAMERA. Connect it to its "Fischer" outlet [b].

The on/off switch [c] is on top, the iris rotary knob [a] and the "Fischer" connector [b] for the B&W VIDEO ASSIST MONITOR are on the front side of the B&W VIDEO CAMERA. By adjusting a mechanical iris in the video camera lens with the rotary knob [a], the video sensitivity is adapted to the brightness of the viewfinder image.

Caution: Protect the small B&W monitor tube against strong lights (e.g. strong luminaires in frame) – it might get damaged! This should also be taken into consideration when adjusting the brightness of the movielite luminous frames.

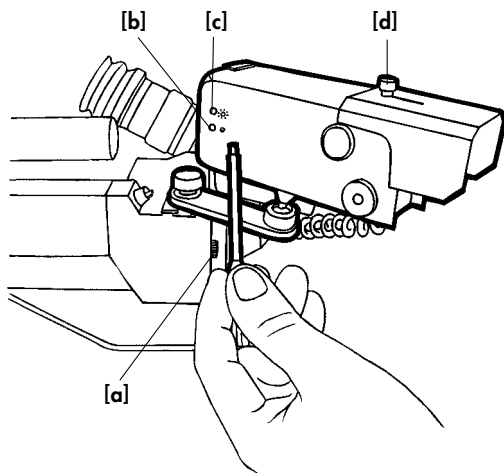

Fig. 49 – B&W VIDEO CAMERA AND
B&W VIDEO ASSIST MONITOR

Adjust brightness and contrast with a small screwdriver (ca. 2 mm). The trim potentiometers are located on the video camera system board and can be operated through two small openings **[b]** + **[c]** only. Standard data should only be changed if absolutely necessary. The viewfinder image is adjusted with the **video iris rotary knob [a]**.

Caution: Adjust video iris only after lens aperture of the MOVIECAM COMPACT has been set!

Loosen the **adjusting screw [d]** and pull the small sunshade **[e]** forward to avoid reflections on the monitor screen.

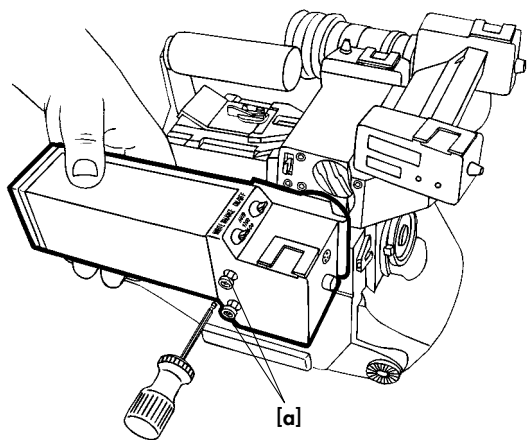
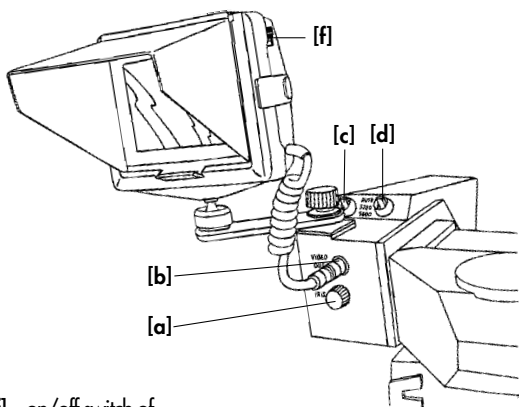

Fig. 50 – COLOR VIDEO CAMERA

*Like the B&W VIDEO CAMERA, the COLOR VIDEO CAMERAS are mounted to one of the VIEWFINDERS with two M5 Allen screws **[a]**. Do not forget to disconnect the MOVIECAM COMPACT first!*



[f] on/off switch of video assist color monitor

Fig. 51 – COLOR VIDEO CAMERA

The *COLOR VIDEO CAMERA* has a **iris rotary knob [a]** to adjust the video iris mechanically, a “Fischer” video outlet **[b]** for the *VIDEO ASSIST COLOR MONITOR*, an **on/off switch [c]** and a “°K” **toggle switch [d]** to adjust the color sensitivity. By this switch, information about the color temperature of the shot is passed on to the camera electronics which then adjusts the white balance. In the **auto position**, the *COLOR VIDEO CAMERA* uses an integrated measuring system to achieve a “neutral” color reproduction. When shooting in daylight, the toggle switch is set to **5.600°K**; when using “Wratten 85” or similar color correction filters during daylight shots, set the switch to **3.200°K** (used for shooting in incandescent light). Switch the monitor on and off with the **on/off slide switch [f]**.

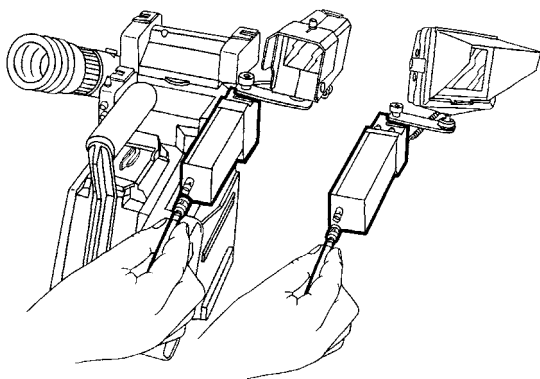

Fig. 52 – CONNECTING THE VIDEO CAMERAS

At the rear of both B&W and COLOR VIDEO CAMERAS there is a BNC video outlet to connect various devices, e.g. monitors, recorders or transmitters.

The cables should not restrict the operator's mobility!

Caution: When a device is connected, care should be taken that no tension is exerted on the camera – otherwise the connector and thus the video camera and the MOVIECAM COMPACT itself might be damaged!

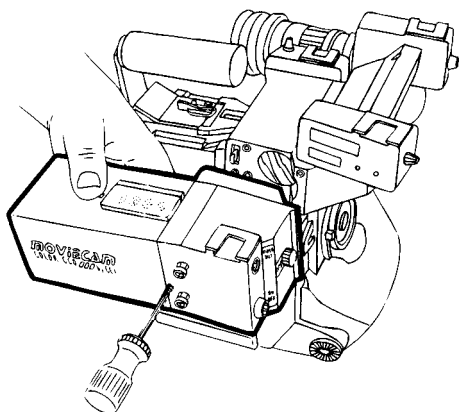

Fig. 53 – NTSC CEI COLOR VIDEO CAMERA

In addition to the PAL und NTSC color video cameras for the MOVIECAM COMPACT, which provided flicker-free video images only at frame rates of 25 resp. 30 fps and 50 resp. 60 Hz, MOVIECAM offers a further color video camera, especially for the use in countries where NTSC / 60 Hz is the video standard. This camera has been designed by CEI TECHNOLOGY.

For more information, you can either contact MOVIECAM or directly CEI at the address mentioned on page 78.

This CEI VIDEO CAMERA is attached to the COMPACT like the other video cameras and provides a high-quality flicker-free NTSC video image at 24 and 30 fps. According to the frame rate chosen – 24 or 30 fps – the video camera has to be adjusted manually with a flip switch. For different frame speeds, the flicker is not suppressed.

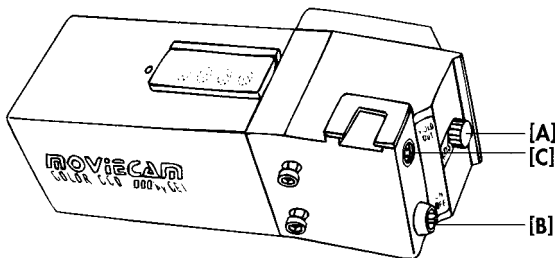

Fig. 54 – NTSC CEI COLOR VIDEO CAMERA

On the front side of the new flicker-free NTSC CEI COLOR VIDEO CAMERA there are the IRIS rotary knob [A] to adjust the iris aperture of the video camera, an on/ off switch [B] for the CCD camera and a "Fischer" connector [C] for a 60 Hz Video Assist Monitor (LCD NTSC color monitor or B&W monitor).

Fig. 55 – NTSC CEI COLOR VIDEO CAMERA

On top of the CEI video camera there are, apart from a LED [A], four flip switches below a transparent hinged lid. The LED [A] lights up when the CCD video camera is on.

Switch functions:

- Flip switch 1 to left: flicker-free image transmission at 30 fps.
in central position: image transmission for other frame speeds without suppressing the flicker.
to right: flicker-free image transmission at 24 fps.
- Flip switch 2 to left: 5.600° K.
in central position: 3.200° K.
to right: automatic white balance.
- Flip switch 3 to left: Gain on.
to right: Gain off.
- Flip switch 4 to left: B & W mode.
to right: Color mode.

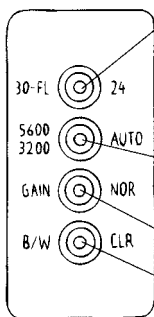

[A]

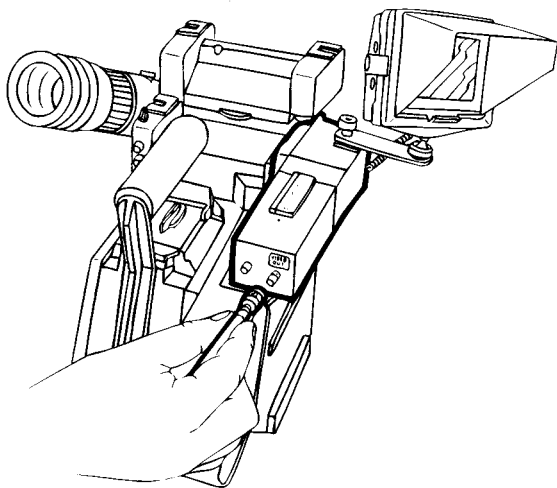

Fig. 56 – NTSC CEI COLOR VIDEO CAMERA

A BNC plug at the camera back provides the 60 Hz video signal.

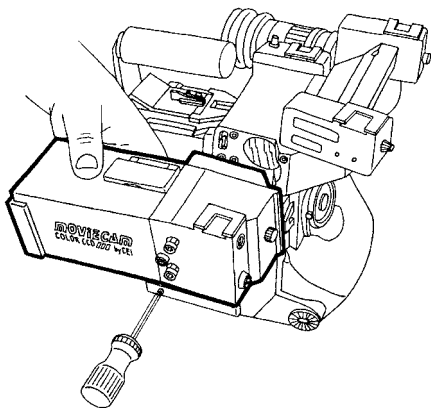

FIG. 57 – MOVIECAM – CEI V
COLOR CCD VIDEO PICK UP

1998 CEI introduced two up-dated versions of their well known video camera.

The new types are the CEI-V PAL and the CEI-V NTSC. MOVIECAM now offers these CCD cameras in customised versions, each type is recognisable on the label on the camera top. These new types has been specially designed to fit the MOVIECAMSYSTEM and do not require adaptation operation. Like the other MOVIECAM VIDEO CAMERAS, only the tightening of 2 screws on the right side of the viewfinders will assure a firm positioning. By attaching the CEI-V camera to the viewfinder, the request 12V power is supplied directly from the film camera.

The new CEI-V cameras can be operate with the COMPACT and – by using the adapter, also can be use with the SL. In case of problems, contact either your MOVIECAM RENTAL HOUSE or directly CEI at the following address:

CEI Technology Inc.
1141 Catalina Dr. PMB 163
Livermore, CA 94550, USA

Phone: 01(925) 606-0766
Fax: 01(925) 606-9996
E-mail: ceiasist@aol.com
Web: www.ceitechnology.com

Caution: The new camera types will run warm. This is normal and is caused by the high density integration of the camera and frame store in small package. The high temperature of the case is necessary in order to remove heat from the inside of the housing.

Due to the built-in frame store, the CEI-V allowed flicker free video reproduction in the full range of filming frame rates, 2-50 fps, allowed by MOVIECAM. Therefore, the CEI-V camera must be connected by using the special cable (Fig. 61) to the MOVIECAM SYNC OUT plug that provide the shutter pulse (SP). The difference between both new video cameras types is that the one is conceived to be use in countries with the NTSC video system and operating with 60 Hz and the other one is conceived for PAL/50 Hz operation. By using the adequate video camera type and by correct set up of the switches, you will obtain high-quality flicker-free video images, independently from the chosen frame rate.

Remark: only valid for PAL version.
If flicker is still seen when the flip switch 1 is set to 25 fps (see Fig. 59 page 80), connect the video camera (SYNC) with the COMPACT (SYNC OUT) by means of the MOVIECAM Sync Video Cable – see page 84.

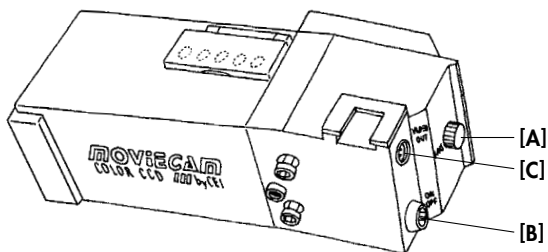

FIG. 58 – MOVIECAM – CEI V
COLOR CCD VIDEO PICK UP

On the front side of the new CEI-V color video cameras there are the IRIS rotary knob [A] to adjust the iris aperture of the video camera, an on/off switch [B] for the CCD camera and a monitor connector 4-pin "Fischer" for a 50Hz or 60 Hz Video Assist Monitor (LCD color monitor or B&W monitor) [C] depending of the camera type.

The iris must be set properly in order for the wide range automatic gain in the Color-V to accommodate the largest range of contrast and brightness.

To set the iris:

Open the iris as far as possible without causing flare in the picture. Flare will appear as a halo or glare surrounding bright objects. Adjust the iris control to give the system as much light as possible. This will assure the "quietest" pictures possible.

If pictures are "noisy", check to be sure the iris is open sufficiently.

FIG. 59 – MOVIECAM – CEI V
COLOR CCD VIDEO PICK UP

On top of the video cameras there are, apart from an LED, five flip switches below a transparent hinged lid. The LED [E] lights green up when the CCD video camera is on. The LED also acts as a low-voltage meter, it will flash when the supply voltage falls to approximately 9.5 volts D. C.

Switch functions:

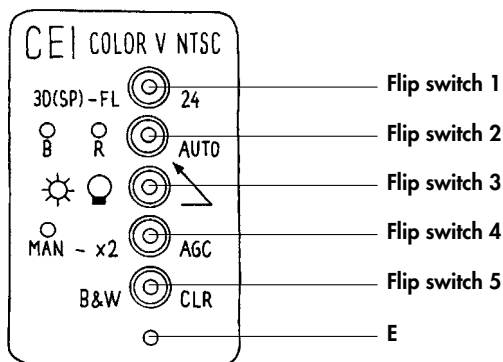

Flip switch 1

The flicker free control is a 3-position switch with the following functions:

right: the CEI-V will be flicker-free at the filming speed of 24 fps

center: the CEI-V acts like a common video camera and is not flicker free

left: the CEI-V will test the incoming ports to see if there is an external driving signal, such as a

shutter pulse from the film camera. If there is no external driver, the CEI-V defaults to flicker free image transmission at 30 fps for NTSC type or 25 fps for PAL model.

If a shutter pulse or equivalent (e.g generator) is present on the incoming port, the CEI-V will follow that driving signal to produce either flicker free at all film speeds, or the function facilitated by the FLX C5 frameline generator to the CEI-V. When driven by the film camera, the CEI-V has the ability to remain flicker free continuously at all filming speeds, even during the ramping of shutter speeds.

Flip switch 2+3

The white balance control is maintained through a combination of two switches.

For normal white balance both switches should be set fully to the right. In this position the lower **switch 3** defaults to the upper **switch 2**, and the upper **switch 3** is in automatic mode. The automatic white balance will continuously try to achieve white balance in this position. Automatic white balance works well most of the time, but under certain conditions one of the following settings may be more appropriate. Moving the upper **switch 2** to the R (red) and B (blue) manual pots allows for manual balance, which can be useful in color matching two or more CEI-V Systems. The **switch 3** must be in the rightmost position in order for the upper **switch 2** to make a selection between auto or manual.

Moving the **switch 2** to either outdoor or indoor disables the automatic and manual and sets the color balance to either indoor or outdoor color temperature. These two temperatures are preset at the factory.

Flip switch 4

The gain switch is a three-position switch that controls the sensitivity of the CEI-V.

right: The normal position is AGC (automatic gain control). Here the camera will automatically adjust the sensitivity to maintain normal video signal output, provided there is sufficient light to do so.

center: In the "X2" position, the sampling speed of the camera is cut in half. This doubles the sensitivity of the CEI-V with no increase in noise. Because the sampling speed is cut in half, serious motion artifacts (strobing) will be more evident.

left: The third position is for manual gain control. To manually set the gain, use the screwdriver control recessed in the control panel. This position should only be used when absolutely necessary, such as in severely, backlighted scenes.

Flip switch 5

right: Color mode

left: B & W mode

Sensitivity and picture quality are identical in either the b&w or color mode.

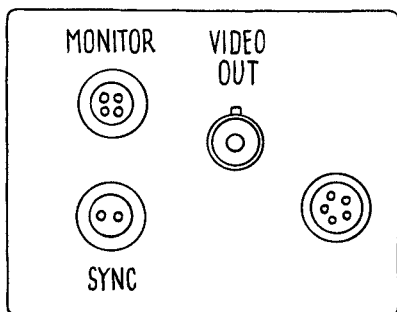

FIG. 60 – MOVIECAM – CEI V
COLOR CCD VIDEO PICK UP

At the rear of the new CEI-V cameras there is

Monitor outlet: *Use this plug to connect a on-board monitor when the orientable viewfinder is used on the right side of the camera.*
(4-pin Fischer)

Sync connector: *to connect with the sync out plug of the MOVIECAM*
(2-pin Fischer)

FLX connector: *to connect the FLX C5 framelines generator*
(6-pin Hirose)

BNC video outlet: *to connect various devices, e.g. monitors, recorders or transmitters.*

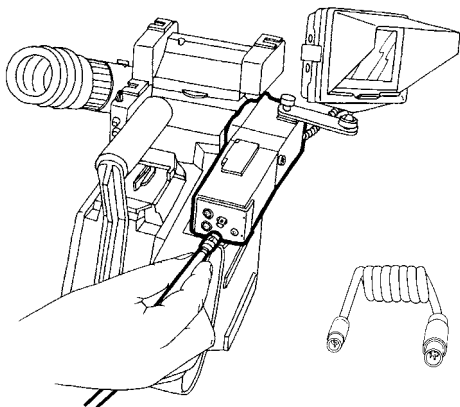

FIG. 61 – MOVIECAM – CEI V
COLOR CCD VIDEO PICK UP

Use the MOVIECAM Sync cable to connect the MOVIECAM SYNC OUT with the CEI-V SYNC connector. The cables should not restrict the operator's mobility!

Caution: When a device is connected, care should be taken that no tension is exerted on the camera – otherwise the connector and thus the video camera and the MOVIECAM itself might be damaged!

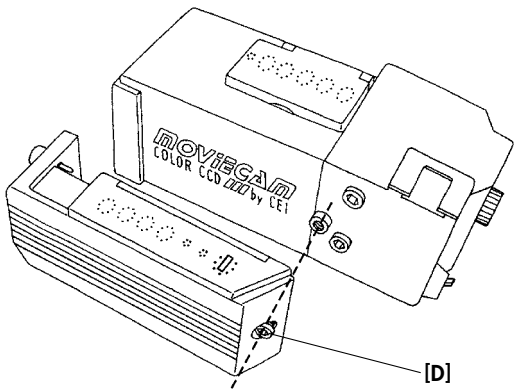

FIG. 62 – CEI ACCESSORY

The FLX C5 is a special function generator that can add to the picture display such things as: framelines, masking, film footage, film speed, time code, user bits, a white flag indicating "new picture" and also video exposure control.

This accessory, it has been redesigned by MOVIECAM with a rain protective cover, "docks" on by simply sliding it piggyback onto the CEI-V and fixed by tightening the screw [D]. It will automatically make most of the necessary connections via the 6-pin connector on the rear of the CEI-V. It is held in place by two pins in the rear and a single screw into the top front. The FLX C5 is powered anytime the CEI-V is on.

In order to use correctly all the possibilities offered by the FLX C5 accessory, it is recommended to consult the separate operators manual provided by CEI.

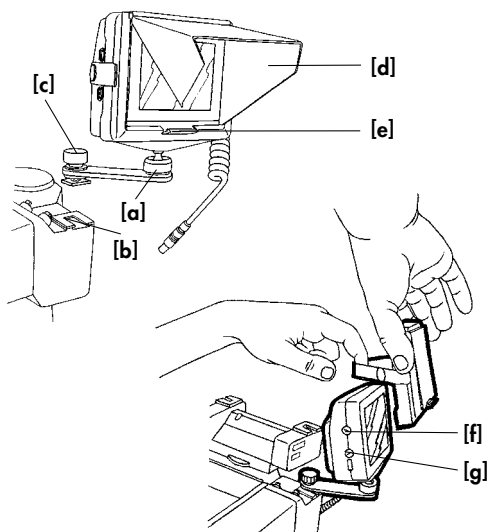

Fig. 63a and 63b –
3,5" VIDEO ASSIST COLOR MONITOR

The small VIDEO ASSIST COLOR MONITOR 3,5" is mounted mobile on a ball joint **[a]**.

It can be mounted to the accessory bracket **[b]** of the COLORVIDEO CAMERAS and fixed with the screw **[c]**.

Attach the sunshade **[d]** to the monitor with a rubber band. Depress the bracket **[e]** of the sunshade, pull up the shade and unfold the side parts until they lock into place.

Adjust brightness **[f]** and color intensity **[g]** with the rotary knobs; the contrast can not be adjusted – it differs according to the viewing angle toward the monitor.

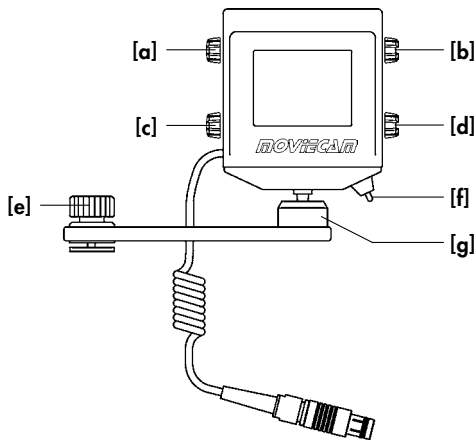

Fig. 64 –
2" VIDEO ASSIST COLOR MONITOR

The 2" Video Assist Color Monitor is mounted on a ball joint. This attachment, fixed on a small arm, can be mounted on several Accessory Bracket where it has to be tightened by a screw [e]. The tension of the ball joint can be regulated by turning the ring [g].

Turn the Video Assist Monitor ON and OFF with the ON/OFF switch [f]. Colour saturation [b], colour hue (NTSC only) [d], brightness [c] and contrast [a] can be adjusted with four rotary knobs.

Caution!

- **This 2" Video Monitor is primarily conceived for shooting Standard 35 format. While shooting in a Super 35 format minimal portions of the image are not screened on the left and right.**
- **ARRICAM On Board Monitors are not compatible with the MOVIECAM Video Assist.**

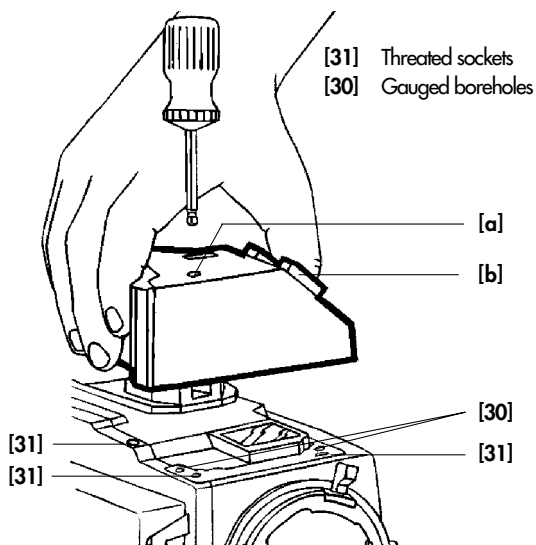

Fig. 65 – THE VIDEO VIEWFINDER

The STANDARD VIEWFINDER may be interchanged against a VIDEO VIEWFINDER which is also mounted with three M5 Allen screws **[a]**. Pins and connectors should engage easily. Care should be taken that everything is clean.

The VIDEO VIEWFINDER has no beamsplitter and thus provides 100% light transmission for a B&W or COLOR CAMERA attached to the right side. Here again, the RIGHT EYEPIECE may be mounted instead of a VIDEO CAMERA.

The VIDEO VIEWFINDER has no filter wheel. No READOUT can be attached. A receptacle for the REMOTE CONTROL BOX is provided under a small cover plate **[b]**.

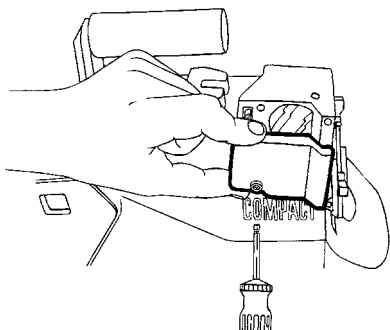

Fig. 66 – VIDEO VIEWFINDER

The covers of the VIDEO VIEWFINDER are similar to that of the STANDARD VIEWFINDER.

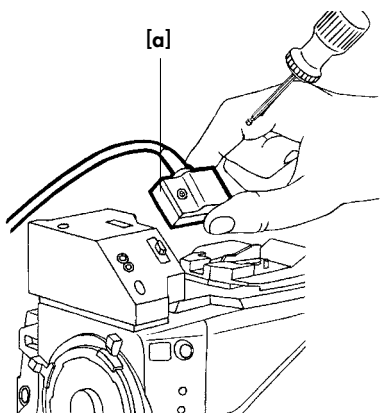

Fig. 67 – VIDEO VIEWFINDER/REMOTE CONTROL BOX

[a] Remote control connector

The REMOTE CONTROL BOX may also be connected to the VIDEO VIEWFINDER.

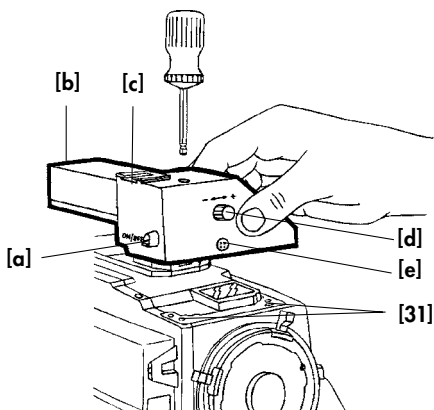

Fig. 68 – LIGHTWEIGHT B&W VIDEO VIEWFINDER

[31] Two threaded sockets

Unlike the other viewfinders, the *LIGHTWEIGHT B&W VIDEO VIEWFINDER* is mounted to the camera body with only two M5 Allen screws.

On this *VIEWFINDER*, there are the **on/off switch [a]**, the **iris control rotary knob [d]** of the integrated B&W video camera lens, a BNC video outlet **[b]**, an attachment **[c]** and a “Fischer” connector **[e]** for an on-board B&W VIDEO ASSIST MONITOR.

MOVELITE, *READOUT* and *REMOTE CONTROL BOX* cannot be used with this *LIGHTWEIGHT B&W VIDEO VIEWFINDER*; it is designed mainly for *STEADICAM* shots.

Notes:

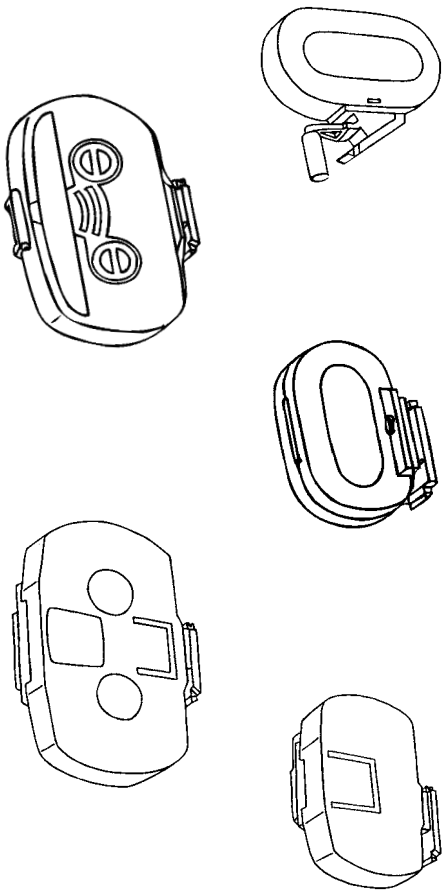

CHAPTER 4

THE MAGAZINES

MOVIECAM offers 5 MAGAZINES for the COMPACT:

- 1) 1.000 ft/300 m LIGHTWEIGHT MAGAZINE
- 2) 1.000 ft/300 m MAGAZINE
- 3) 1.400 ft/150 m LIGHTWEIGHT MAGAZINE
- 4) 1.500 ft/150 m MAGAZINE
- 5) 1.400 ft/120 m STEADICAM MAGAZINE

The MAGAZINES have to be thoroughly clean.
Remove any smudges immediately!

a) MAGAZINE interior:

Clean interior and film plates from dust carefully with a vacuum cleaner. Use compressed air only very cautiously.

An intact sealing rubber band is elastic and slightly flattened at the top. Inspect it regularly for mechanical damage and clean with a **dry** cloth – do not use solvents!

If necessary, dab the velvet rollers carefully with adhesive tape.

b) MAGAZINE exterior:

Clean magazine lacquer and plexi-glass cover with a window cleaner (caution – do not moisten connector!). Keep connector, tightening wheels and footage counter clean and inspect them for mechanical damage. Clean light trap plate thoroughly before attaching it to the camera. MAGAZINES should always be protected by a clean LOOP PROTECTOR.

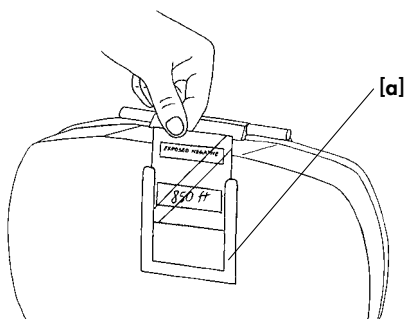

Fig. 69 – MAGAZINE 500/150 LEFT SIDE

*Self-adhesive labels, supplied by the rental houses, can be slid into a holder **[a]** at the outside of the magazine cover (left side). Use these labels to identify exposed film later on; stick them onto film cans.*

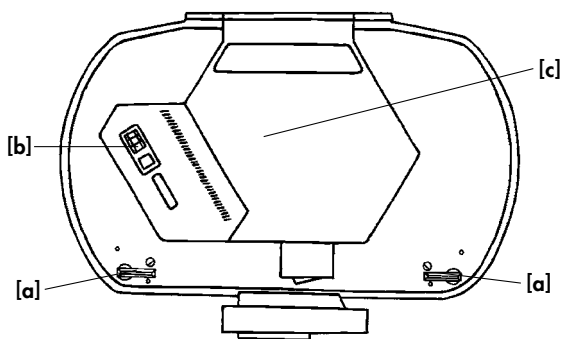

Fig. 70 – MAGAZINE 1.000/300 RIGHT SIDE

*Motors, heater **[c]**, digital footage counter **[b]** and latches **[a]** are located at the right side of a 1.000/300 or 500/150 MAGAZINE.*

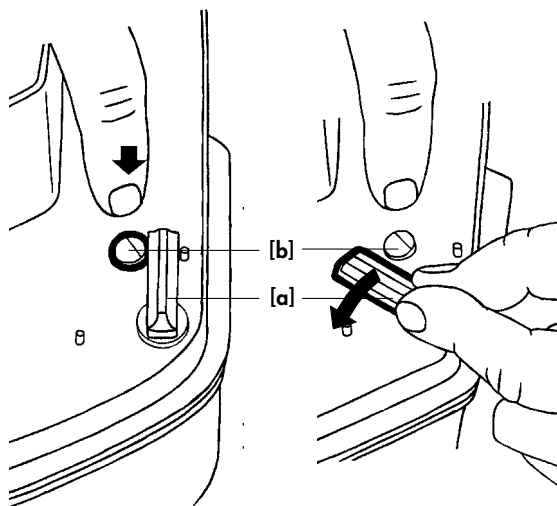
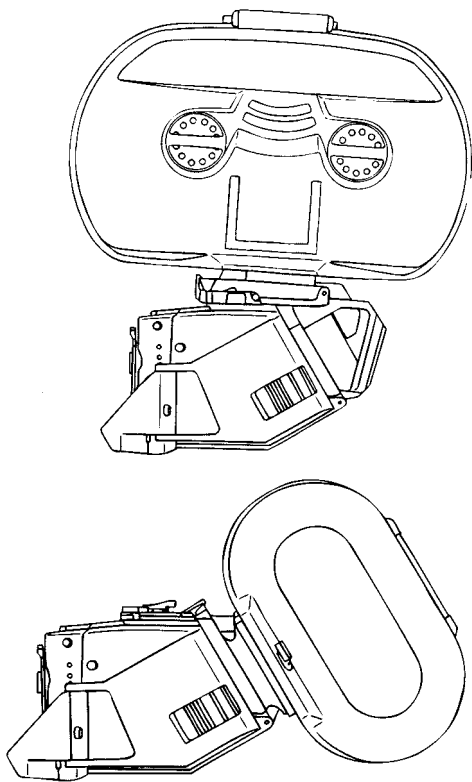

Fig. 71 – MAGAZINE LATCH

To open a MAGAZINE, lay it down on its right side (footage counter side). Press the small **black safety buttons [b]** (with your middle finger) and hold them; this permits to easily turn the **latches [a]** toward each other with your index finger.



— Fig. 72/ 73 – LEIGHTWEIGHT MAGAZINES —

The new 400ft/ 120m and 1.000ft/ 300m LIGHTWEIGHT MAGAZINES differ from the older aluminium types by new materials and a new design. A glassfiber reinforced plastic/ carbon blend now enables the production of considerably lighter magazines without losing stability and with the same acoustic properties as its predecessors out of aluminium.

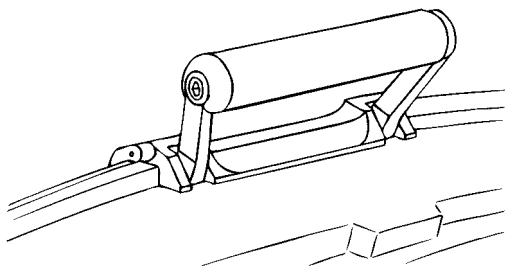

Fig. 74 - LEIGHTWEIGHT MAGAZINE

On top of the 1.000ft/ 300m LEIGHTWEIGHT MAGAZINE a foldable handle has been added. All other parts, such as motors, heater, counter and manual tightening device, are identical with the aluminium model.

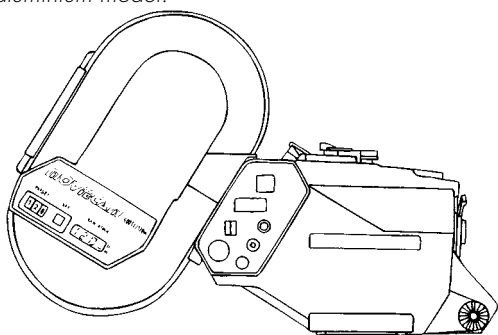

Fig. 75 - LEIGHTWEIGHT MAGAZINE

The 400ft/ 120m LEIGHTWEIGHT MAGAZINE has, apart from its camera attachment angle, the same shape as the lightweight magazine designed especially for STEADICAM shots. However, the new magazine has heater elements which have, due to weight reasons, not been built into the STEADICAM magazine.

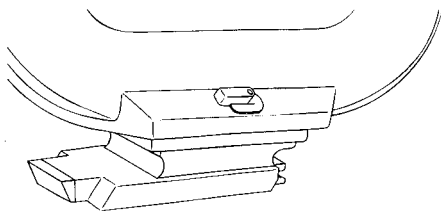

Fig. 76 - LEIGHTWEIGHT MAGAZINE

Left and right lockers of the aluminium design have been replaced by a central locker (400ft/120m only). The small lock lever **[A]** is, when locked, secured by a spring steel safety tab **[B]**.

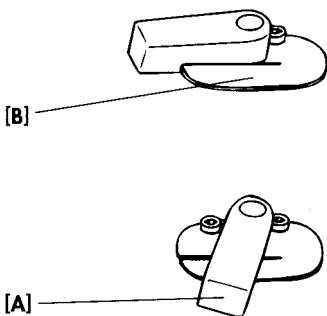

Fig. 77 - LEIGHTWEIGHT MAGAZINE

Open the magazine by pressing the safety tab down and turning the lever counter-clockwise. When closing, the safety tab automatically prevents an unintended opening.

Caution: Do not twist the safety tab!

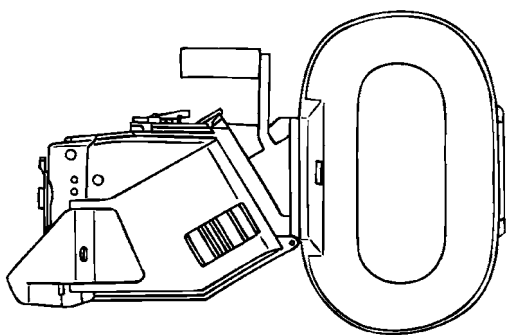

Fig. 78 – 400/120 MAGAZINE
FOR STEADICAM OPERATION

This extremely lightweight plastic MAGAZINE was developed for STEADICAM shots.

*The carrying handle can be removed by unscrewing two M5 Allen screws (see page 136). Apart from that, the magazines are alike. The latch is secured by a thin spring steel safety tab. Open the MAGAZINE by depressing this **safety tab** (see figure 117 [c]) down and turning the **latch** clockwise 180°.*

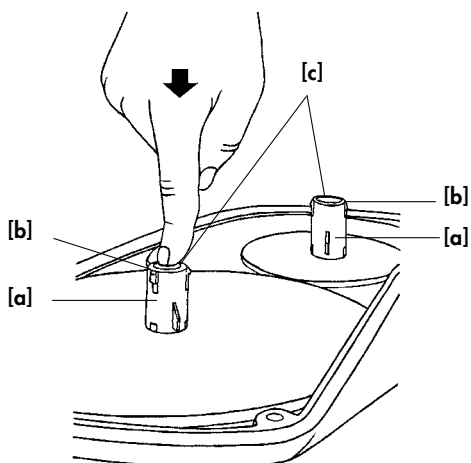

Fig. 79 – CORE HOLDER

Checking core holders **[a]** and core locks **[b]**:

By pressing the **release knob [c]** on top of the core holder, the three core locks move inward.

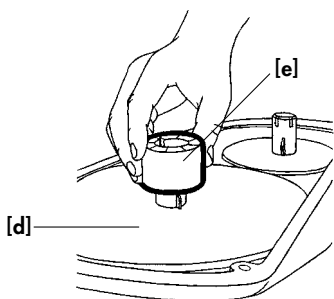
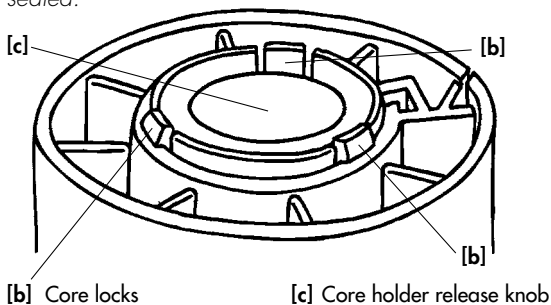

Fig. 80 – CORE HOLDER

Now put a core [e] on the film plate [d] until you hear a first “click”. Hold the plate and – simultaneously – turn the core gently to the left or right until you hear a second “click”. **Only now** the core is properly seated.



[b] Core locks

[c] Core holder release knob

Fig. 81 – CORE HOLDER

In case you do not hear the “clicks”, the core holder pin has engaged in the hole of the core already at the beginning. It is **not** properly seated – have another try. Locked cores are released by pressing the **release knob [c]** on core holder.

Caution: In case of a malfunction of the core holder, do not disassemble – magazine should be serviced at a rental house.

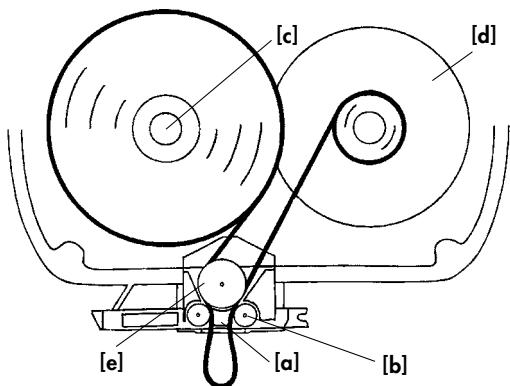

— Fig. 82 – LOADING OF THE MAGAZINE —

- 1) Clean darkroom / changing bag.
- 2) Check and clean MAGAZINE. Insert core in the take-up side **[d]**.
- 3) Lay the MAGAZINE down carefully in the darkroom or changing bag onto footage counter side; roller assembly is facing you.

4) Lift magazine cover.

From now on in darkness.

- 5) Put film roll on empty can and place it to the MAGAZINE left side.
- 6) Wind off just enough film to insert it in the roller assembly to the left of the main roller **[e]**. Gently push the film into the slot until it emerges from the other side.
- 7) Pull approx. 50 cm film toward you. Unlock the left core holder by depressing the **release knob [c]**. Place film roll onto core holder – do **not** press toward MAGAZINE bottom (caution – film might be scratched!).
- 8) Insert film from outside into magazine between magazine nose **[a]** in roller assembly and right roller **[b]**.

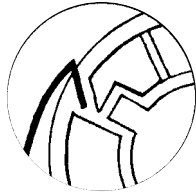
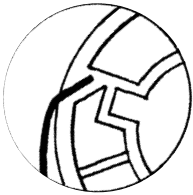

WRONG WAY

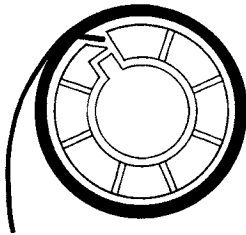

Fig. 83 – LOADING THE MAGAZINE

9) Attach to takeup core. Feed film into core slot so that no acute angle forms when turning the core clockwise! Wind just enough film around take-up core to make sure it will not accidentally slide out again. Wound-up film has to be flush with the core and lie flat on take-up plate.

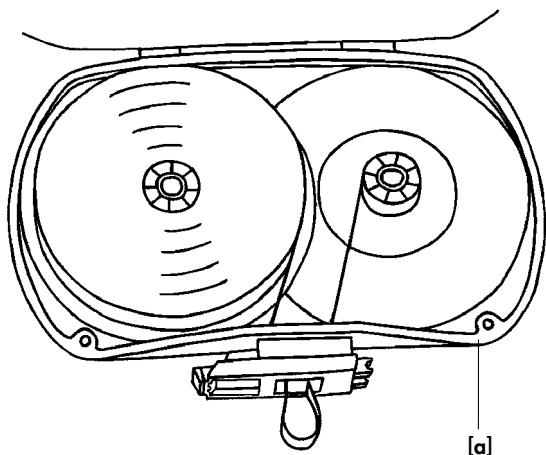

Fig. 84 – LOADING THE MAGAZINE

Caution:

When closing the magazine, care should be taken that nothing (e.g. changing bag, film bag etc.) is caught between magazine cover and -base.

Especially with the 1.000/300 magazine, forcible closing might lead to LIGHT LEAKAGE!

Furthermore, the rubber sealing [a] might be damaged!

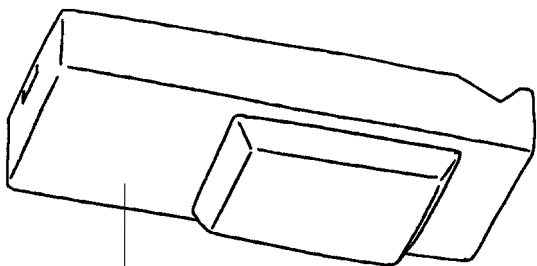

[a]

Fig. 85 – LOOP PROTECTOR

10) The film windings on the feed side must not protrude **below** plate – film might touch the magazine bottom. Close and latch MAGAZINE after checking that film is properly seated and nothing is caught between magazine and cover!

From now on with light.

- 11) attach a LOOP PROTECTOR [a],
- 12) feed length of unexposed film into footage counter (see page 108) and
- 13) insert a label into the assigned holder.

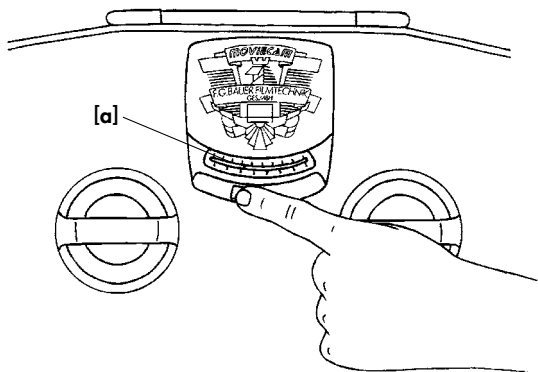

— Fig. 86 – FOOTAGE INDICATOR (manual) —

Each 1.000/300 MAGAZINE has both digital footage counter and analog display [a].

When the camera is not running, move the indicator arm gently to the right; the footage indicator arm will swing toward film. The film length remaining in the magazine left half – usually the unexposed film – is shown on the display.

Although the footage indicator arm is spring loaded, the indicator arm should be moved back manually.

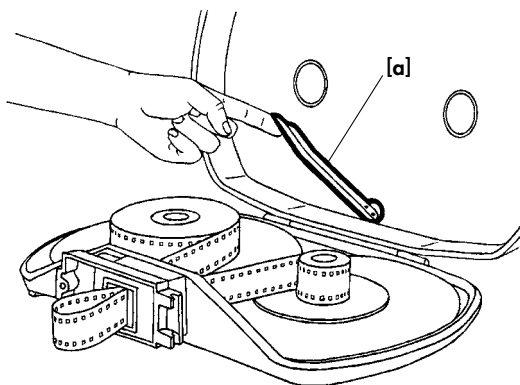

Fig. 87 – FOOTAGE INDICATOR (arm)

The footage indicator arm **[a]** should lie flat on the magazine cover interior. Check spring and arm attachment by gently moving them.

Caution: Due to the length of the footage indicator arm, extreme care should be taken when checking it (leverage)!

Lock lever counterparts in the magazine cover, film tightening wheels and magazine interior have to be absolutely clean.

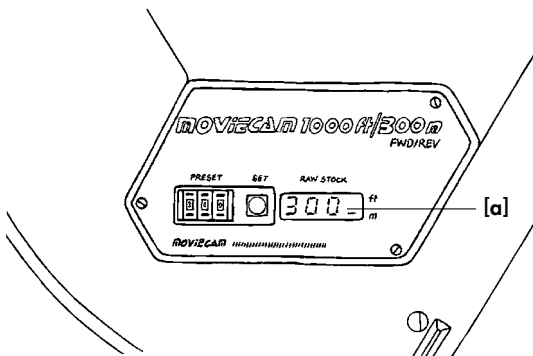

Fig. 88 – DIGITAL FOOTAGE COUNTER

The digital footage counter displays the remaining footage **[a]**; it is powered by its own on-board battery. When a MAGAZINE is attached to a powered camera, the magazine battery recharges automatically.

In case nothing is displayed (which very rarely happens), simply mount the MAGAZINE to a powered camera to reactivate the display. The magazine battery usually recharges automatically during the shooting period.

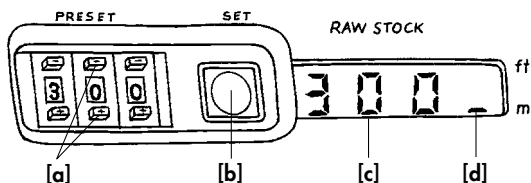

Fig. 89 – DIGITAL FOOTAGE COUNTER

After loading the MAGAZINE, use the **preset buttons [a]** to input the length of film loaded.

By pressing the **set button [b]**, the footage counter stores the input. It counts backward when the camera is running.

The RAW STOCK display **[c]** shows the length of remaining unexposed film.

For reverse filming, set the footage counter to **[000]**. When the camera is running backward, it will count up and display the length of exposed film.

Remaining film length is displayed in either feet or meters – a mark **[d]** next to **[ft]** or **[m]** shows the preset option.

Caution: Ft/m changes should be performed at a rental house only!

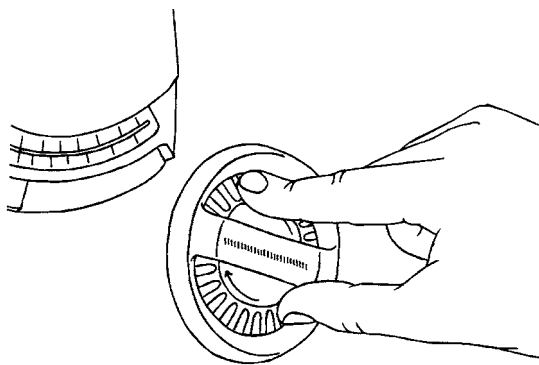

Fig. 90 – TIGHTENING WHEELS

Additionally to the electronically controlled film tightening, a tightening wheel (for manual tightening) for each film plate is built into the cover of the 1.000/300 MAGAZINE.

By depressing the tightening wheel, you may turn the core via friction plates in the direction of the arrow. The spring bringing the tightening wheel back to its resting position can be controlled by depressing slightly.

Caution: In case a tightening wheel does not swing back into its resting position, the magazine has to be repaired. When the camera is running, the tightening wheels must not turn!

When pressing the t.up/bar button [25], both core holders should turn outward. If not, check the safety buckle switch!

Electronic adjustment of the clutch tension and maintenance of the motors below the footage counter as well as the thermostatically controlled heaters should be carried out at a rental house only.

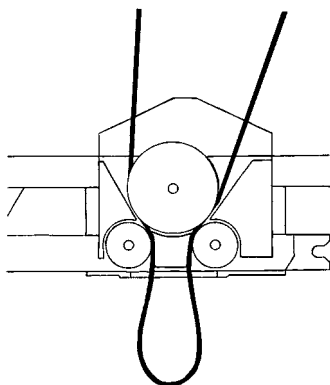

Fig. 91 – ROLLER ASSEMBLY

*The roller assembly contains three rollers, two of which can be velvet clad. Roller bearings should be serviced at a rental house only. The roller assembly is best cleaned with a vacuum cleaner. You may use compressed air to blow the magazine; be careful **not** to blow the velvet rollers directly, they might get damaged.*

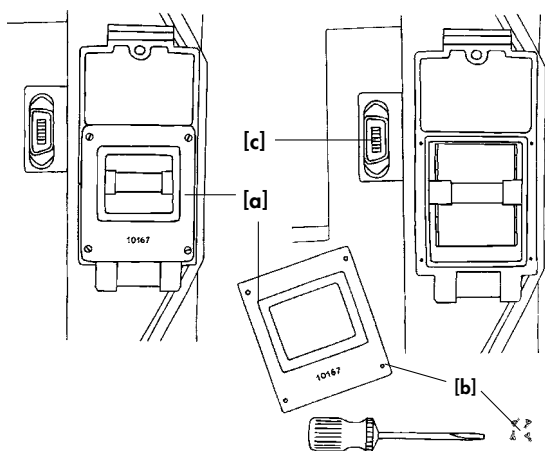

Fig. 92/93 – THE LIGHT TRAP

[c] Magazine connector

To remove film chips and dirt more easily, remove the light trap plate [a] (bearing the magazine serial number) by unscrewing four M2,5 screws [b].

Caution:

Due to the fine threads, the light trap plate should only – very carefully – be removed, if really necessary!

When mounting the plate again, make sure that the plate is clean and plane (light leakage!) and the asymmetrical opening at its right place.

You do not have to remove the roller assembly!

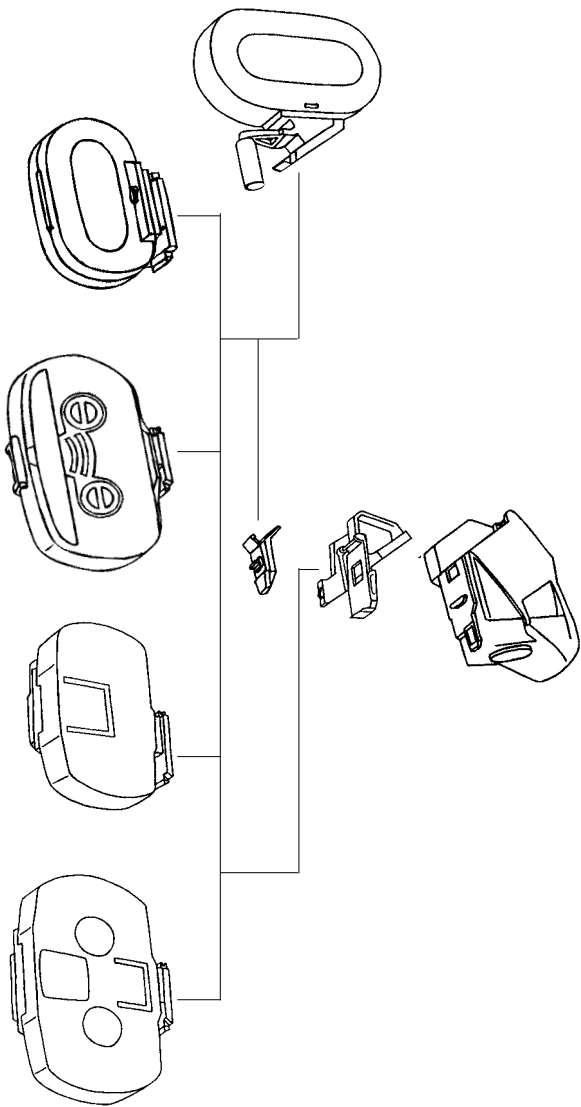

CHAPTER 5
THE ADAPTERS

CHAPTER 5

THE MAGAZIN ADAPTERS

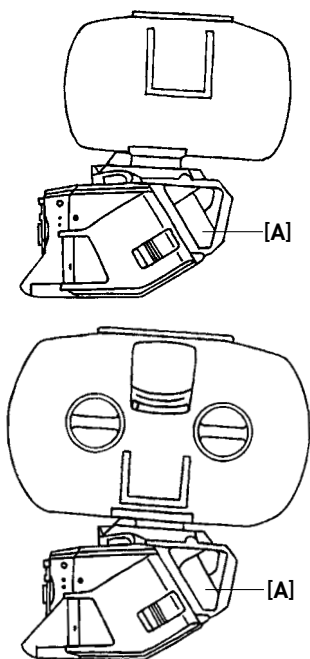

Fig. 94 – MAGAZINE ADAPTERS

There are two possibilities to mount the magazines on the MOVIECAM COMPACT:

- *at the top*
with a TOP MOUNT ADAPTER [A] –
Studio configuration,
- *at the rear*
with a REAR MOUNT ADAPTER –
Shoulder configuration.

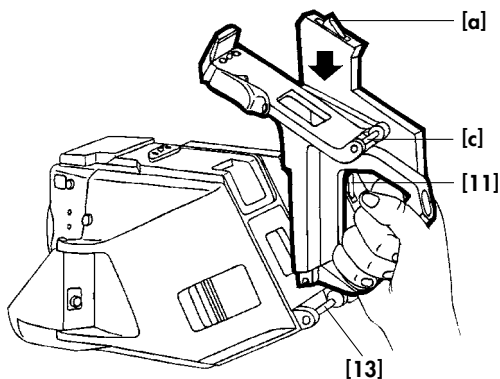

Fig. 95 – THE TOP MOUNT ADAPTER

[c] Mounting rail of the top mount adapter

Mount the TOP MOUNT ADAPTER on the rear magazine rail **[13]** and swing it forward toward camera until the locating pin engages. The TOP MOUNT ADAPTER has two connectors; the upper one **[a]** is attached mobile to facilitate connecting it with the magazine; the lower one connects the TOP MOUNT ADAPTER to the connector **[11]** on the CAMERA BODY.

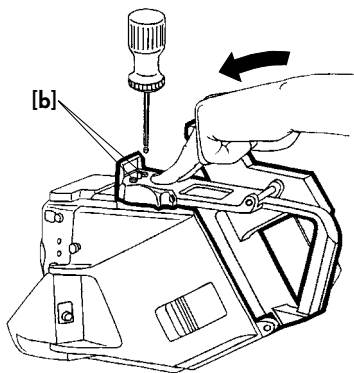
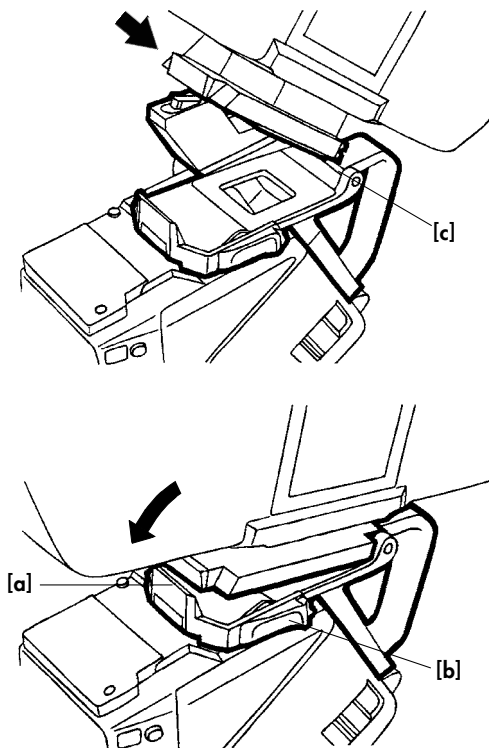

Fig. 96 – THE TOP MOUNT ADAPTER

Gently depress on adapter and tighten both M5 Allen screws [b].

Caution:

When changing adapters, contact surfaces have to be absolutely clean!



— Fig. 97/98 – THE TOP MOUNT ADAPTER —

Mount the *MAGAZINE* to the magazine rail [c] of the *TOP MOUNT ADAPTER*.

Swing the *MAGAZINE* carefully forward toward the camera until it engages in the magazine latch [a].

Caution:

Before mounting the magazine, the latch mechanism [b] has to be open (locking slider in the back position).

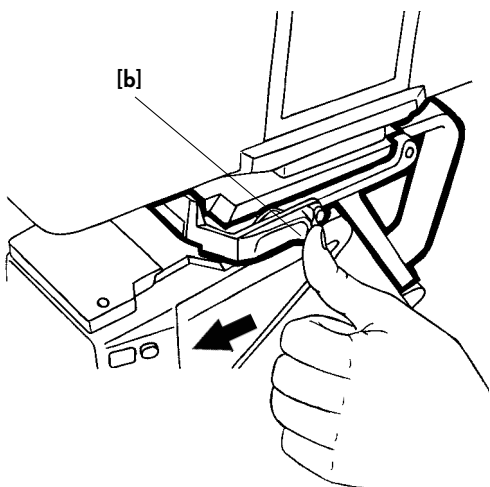

Fig. 99 – THE TOP MOUNT ADAPTER

Do not forget:

Lock the latch mechanism by pulling the locking slider [b] forward.

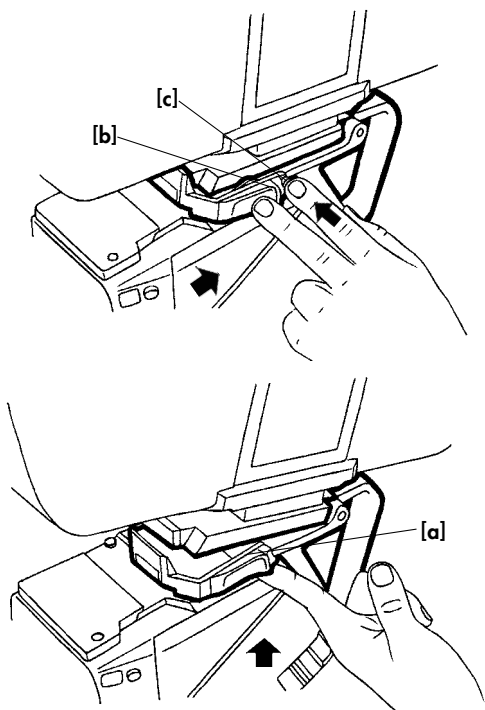

Fig. 100/101 – THE TOP MOUNT ADAPTER

To remove the MAGAZINE, depress the safety button [c], push the locking slider [b] backward.

Lift the locking lever [a] while holding the MAGAZINE!

Do not forget:

A camera COVER PLATE always has to be attached when no magazine is mounted on the camera!

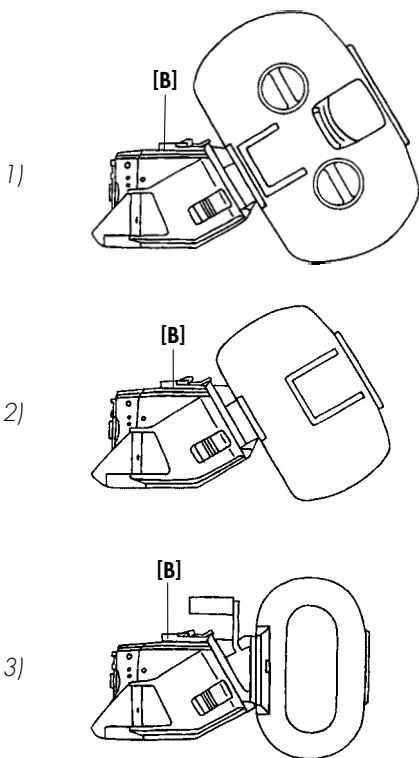

Fig. 102 – THE REAR MOUNT ADAPTER

After removing the TOP MOUNT ADAPTER, attach the MAGAZINE to the CAMERA BODY with the REAR MOUNT ADAPTER [B].

- 1) e.g. Fluid head operation
- 2) e.g. Handheld operation
- 3) e.g. STEADICAM operation

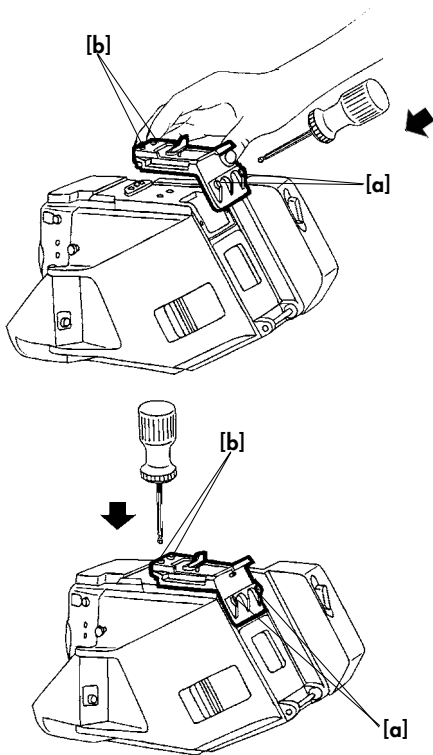

Fig. 103 – REAR MOUNT ADAPTER

The REAR MOUNT ADAPTER is attached to the MOVIECAM COMPACT with four M5 Allen screws. When mounting the REAR MOUNT ADAPTER, tighten the rear screws **[a]** first, then the front screws **[b]**.

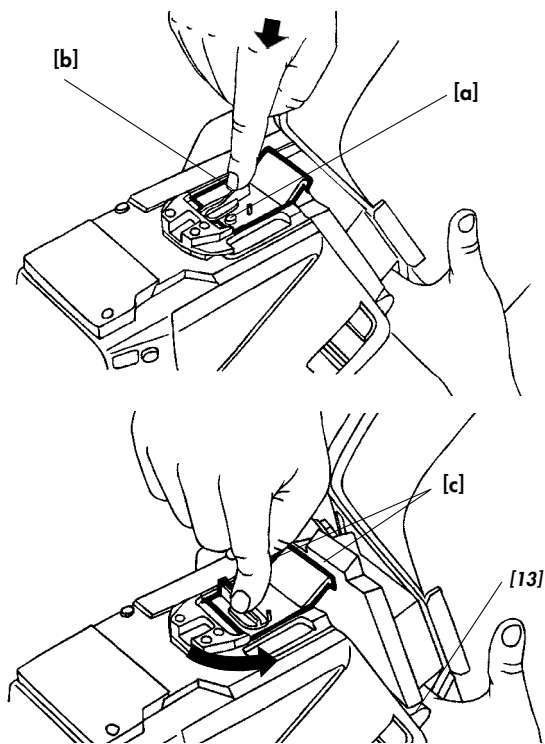

Fig. 104/105 – REAR MOUNT ADAPTER

The REAR MOUNT ADAPTER has a latch mechanism with a safety button.

Caution: Prior to mounting the magazine, the latch mechanism must be open.

To open the latch mechanism, press the safety button [a], turn the locking lever [b] counter-clockwise and press it down.

Attach the MAGAZINE to the camera body mounting rail [13]. Swing the MAGAZINE carefully forward toward the camera body and engage magazine mounting latch in latch [c] on the REAR MOUNT ADAPTER.

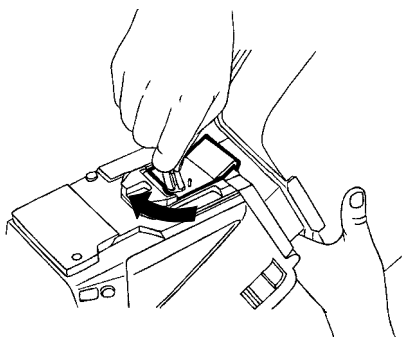

Fig. 106 – REAR MOUNT ADAPTER

Lock the *MAGAZINE* on the camera by turning the locking lever **[b]** clockwise.

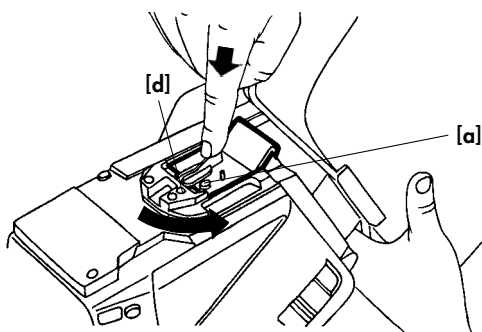

Fig. 107 – REAR MOUNT ADAPTER

To remove the *MAGAZINE*, press the **safety button [a]**, turn the locking lever counter-clockwise and press it down **while holding** the *MAGAZINE*! The *UPPER CARRYING HANDLE* is attached to the threaded socket **[d]** on the top of the *REAR MOUNT ADAPTER*.

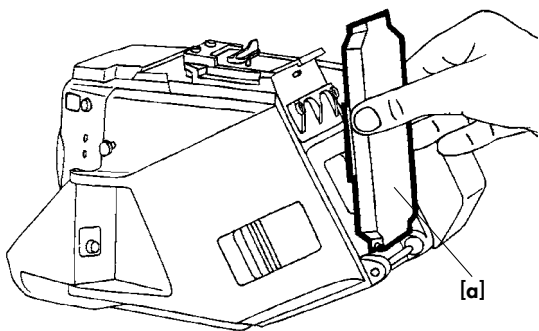
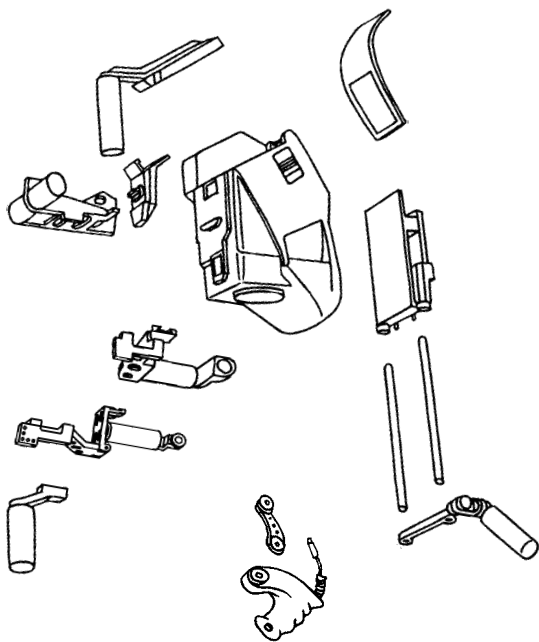

Fig. 108 – CAMERA COVER CAP

Instead of a MAGAZINE, you can attach a CAMERA COVER CAP [a] with or without handgrip – see page 135.

Notes:



CHAPTER 6
THE CARRYING HANDLES AND HANDGRIPS

CHAPTER 6

THE CARRYING HANDLES AND HANDGRIPS

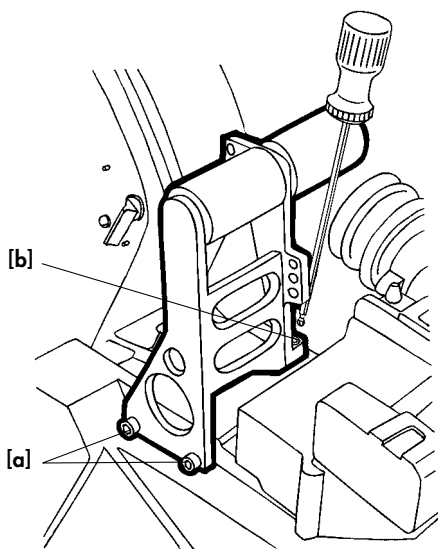

Fig. 109 – UPPER CARRYING HANDLE

Various CARRYING HANDLES have been designed for the MOVIECAM COMPACT to permit ergonomic handling in all configurations.

The UPPER CARRYING HANDLE has been designed for shoulder configuration (magazine mounted to the camera rear). Attach it to the camera right side attachment **[20]** (see page 20) with two M5 Allen screws **[a]** and to the camera top (see page 125) with one M5 Allen screw **[d]**.

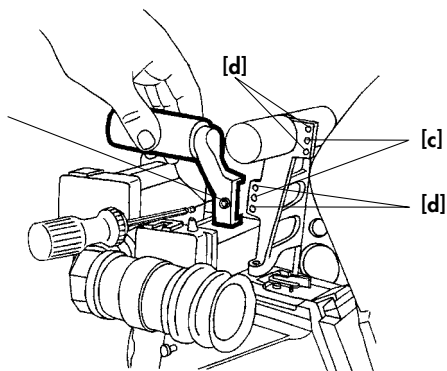

Fig. 110 – AUXILIARY HANDLE

- [c] Threaded socket
- [d] Gauged boreholes

*MOVIECAM provides an AUXILIARY HANDLE for the UPPER CARRYING HANDLE. Mount this small handle to the UPPER CARRYING HANDLE with one M5 Allen screw **[a]** for easier camera handling.*

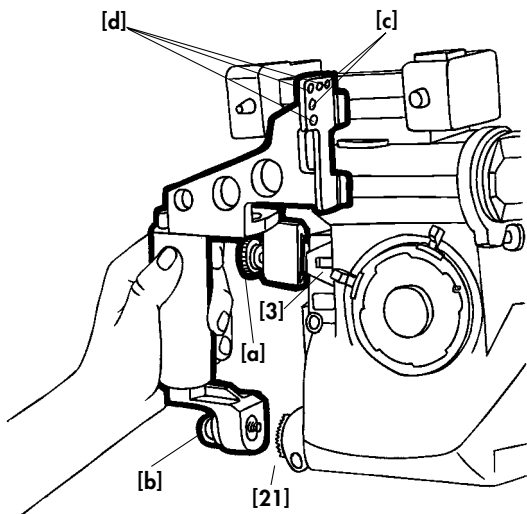

Fig. 111 – SIDE HANDLE

- [c] Threaded sockets
- [d] Gauged boreholes

Use the *SIDE HANDLE* when a *MAGAZINE* is attached to the camera top. Slide this handle onto the dove tail bracket **[3]** and tighten it with the **knurled screw [a]**. Screw the lower part of the handle into the rosette **[21]** with **fixing screw [b]**. This screw has a latch that permits easier handling.

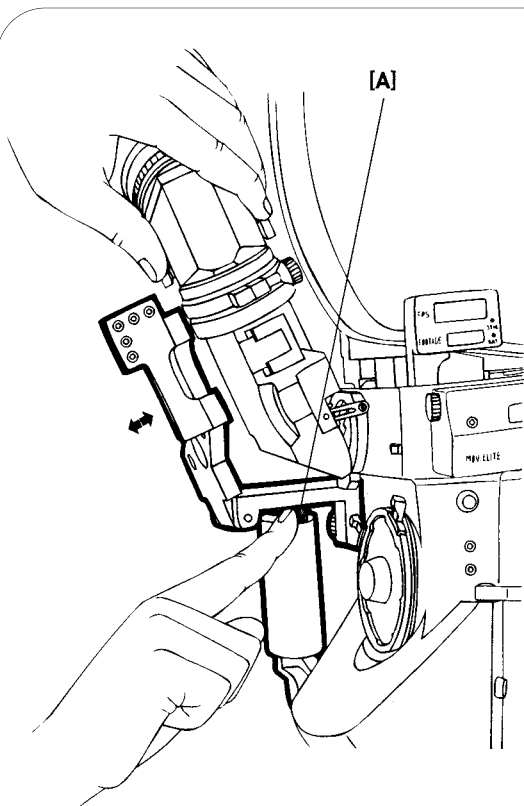

Fig. 112 – SIDE HANDLE

The new SIDE HANDLE has been equipped with a tilting device which allows to pivot the ORIENTABLE VIEWFINDER from one side of the camera to the other, when top-loaded 1000 ft magazines are mounted. After softly pressing the release lever **[A]**, the upper part of the SIDE HANDLE can be tilted forward in order to give way to the bent viewfinder. When the viewfinder is on the other side, the upper part of the handle can be put upright again; it then locks automatically.

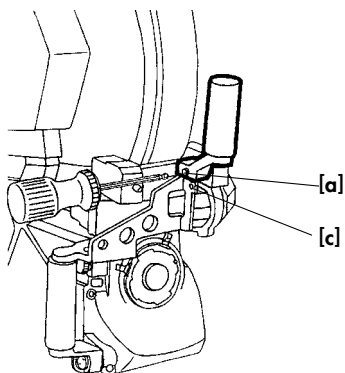

Fig. 113 – AUXILIARY HANDLE

An AUXILIARY HANDLE can be screwed into one of the two threaded sockets **[c]** on top of the SIDE HANDLE.

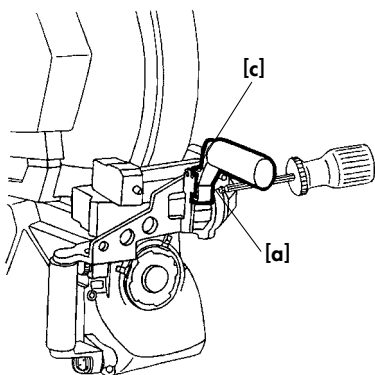

Fig. 114 – AUXILIARY HANDLE

The small AUXILIARY HANDLE, identical with that on page 131, can be attached either vertically or horizontally with one M5 Allen screw **[a]** for easier handling.

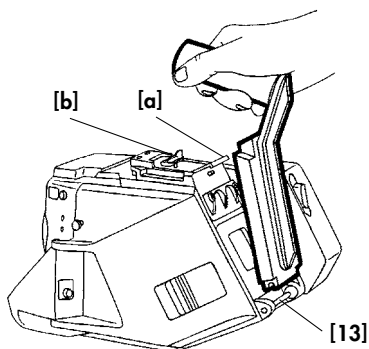

Fig. 115 – REAR CARRYING HANDLE

*Instead of a MAGAZINE, the REAR CARRYING HANDLE can be attached to the camera in the same way: open the latch **[a]** of the REAR LOAD ADAPTER, mount the REAR CARRYING HANDLE on the rail **[13]** and swing it forward toward the camera.*

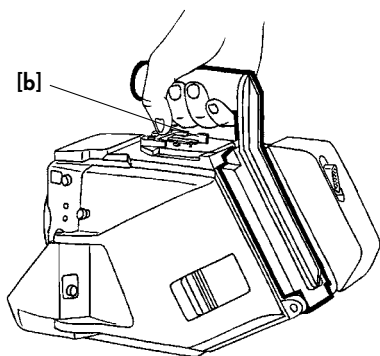

Fig. 116 – REAR CARRYING HANDLE

Caution:

Do not forget to open the latch before mounting the handle!

As soon as the rear handle has engaged, secure the latch by turning clockwise the lever **[b]**!

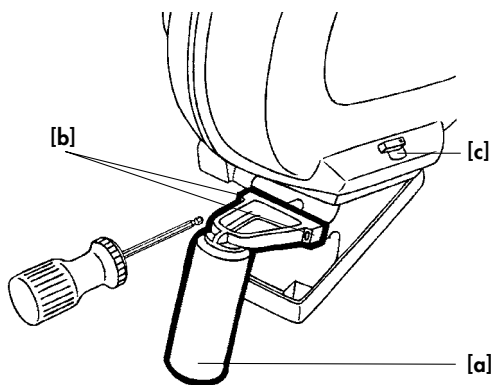

Fig. 117 – 400/120 MAG. CARRYING HANDLE

[c] Single latch and safety tab

Remove the HANDLE **[a]** of the 400/120 LIGHT-WEIGHT MAGAZINE by unscrewing two M5 Allen screws **[b]** to either further reduce the weight or to attach special STEADICAM accessories. See also page 98.

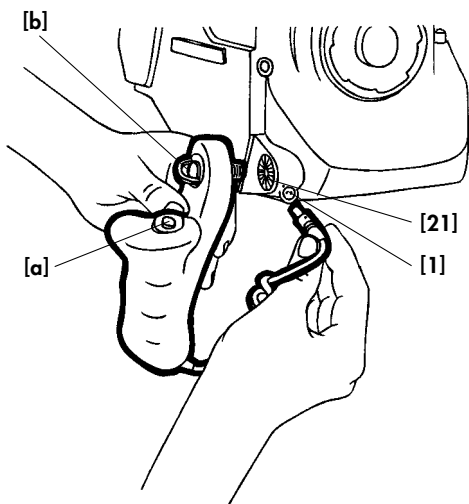
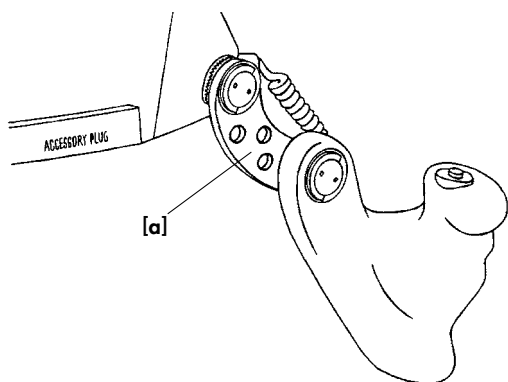

Fig. 118 – RIGHT HANDGRIP

For handheld operation, MOVIECAM offers an ergonomically designed HANDGRIP with built-in on/off button **[a]**. This button works like an “alternating switch”: you can switch on the camera with the handgrip button and switch it off with another (e.g. that on the control board) and vice versa. The HANDGRIP is screwed into the camera rosette **[21]** with screw **[b]** whose mobile latch permits easier handling. Due to the rosette joint, the HANDGRIP may be attached firmly at any vertical angle. Do not forget to connect the handgrip plug to the on/off button outlet **[1]**.



— Fig. 119 – RIGHT HANDGRIP EXTENSION —

A further accessory, the RIGHT HANDGRIP EXTENSION [a], permits to adjust the handgrip position ergonomically. This extension facilitates the simultaneous use of RIGHT HANDGRIP and STUDIO FOLLOW FOCUS.

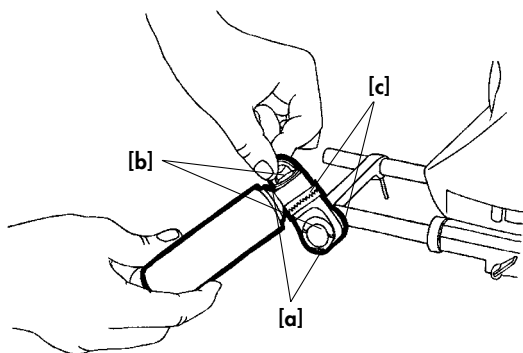

Fig. 120 – LEFT HANDGRIP

*MOVIECAM provides an additional HANDGRIP for the camera left side that can be turned in any direction. Slide the LEFT HANDGRIP onto the SUPPORT RODS and tighten at both sides. To change the handgrip position, lift both latches **[a]** and loosen the screws **[b]**.*

*In the desired position, tighten the screws in both rosette joints **[c]** and put the latches down again.*

Caution: The left handgrip is only an additional support – do not use as carrying handle (onesided strain!).

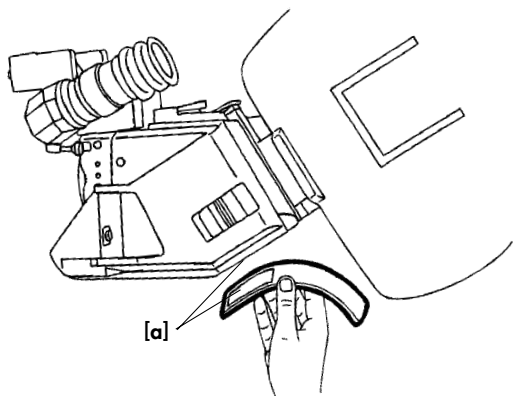
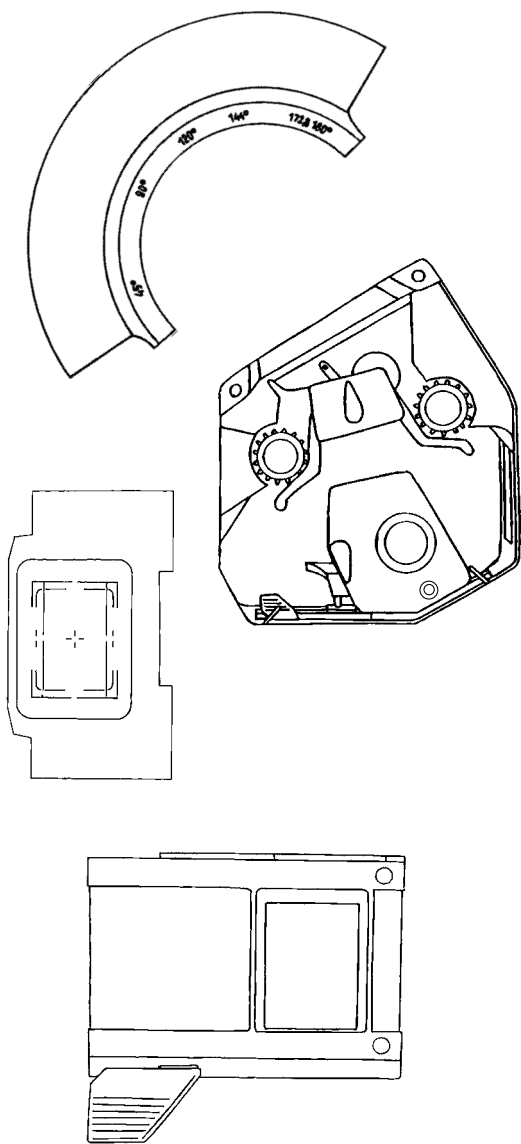

Fig. 121 – PADDED SHOULDER REST

The *PADDED SHOULDER REST* can be easily formed to fit on each shoulder ergonomically. It is attached to the *CAMERA BODY* with **velcro adhesive strips [a]** and permits a comfortable handheld operation of the *MOVIECAM COMPACT*. Both velcro parts must be clean to ensure a good adhesive performance. Regular cleaning or combing saves valuable time and needless trouble.

Notes:



CHAPTER 7
THE INTERIOR OF THE COMPACT

CHAPTER 7

THE INTERIOR
OF THE COMPACT

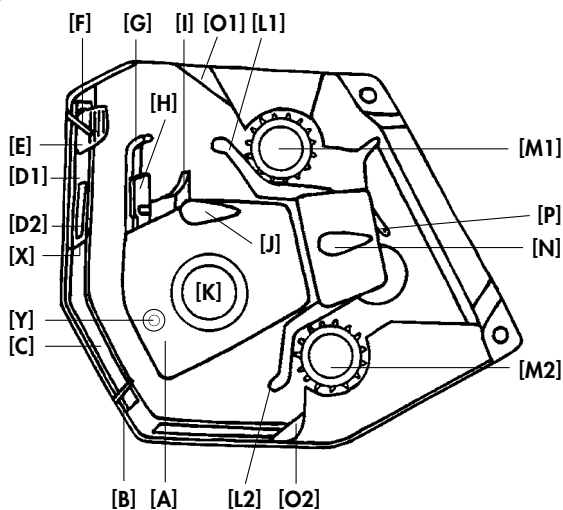

Fig. 122 – INTERIOR OF THE CAMERA

- [A] Movement block
- [B] Lock lever for lower aperture plate
- [C] Lower aperture plate
- [D1] Upper aperture plate
- [D2] Gate
- [E] Handle of upper aperture plate
- [F] Lock lever for upper aperture plate
- [G] Front film guide
- [H] Pressure plate
- [I] Pressure block
- [J] Lever of movement block
- [K] Inching knob
- [L1] Upper rear film guide
- [L2] Lower rear film guide
- [M1] Upper sprocket
- [M2] Lower sprocket
- [N] Lock lever for rear film guides
- [O1] Upper buckle switch
- [O2] Lower buckle switch
- [P] Rear buckle switch
- [X] Mounting rail for aperture plates
- [Y] Pitch adjustment screw

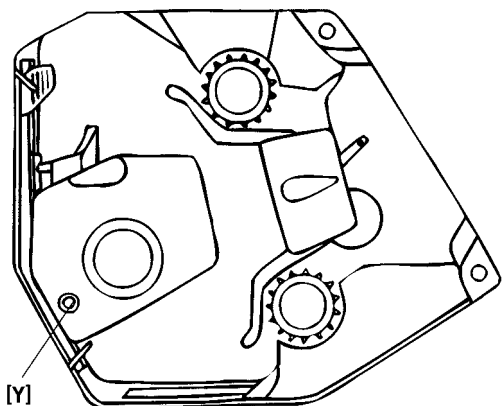

Fig. 123 – PITCH ADJUSTMENT CONTROL

In order to adjust the movement to the properties and dimensions of the film material in use and at the same time achieve an even more quiet and gentle film transport, a PITCH ADJUSTMENT CONTROL has now been built into the movement block of the COMPACT. The PITCH ADJUSTMENT SCREW [Y] has no marks and no buffer stop; the adjusting range is a whole turn of the screw.

*While the camera runs with normal frame speed (24 - 25 fps) and the material to be used, with an M5 Allen screwdriver, by **slowly** turning clockwise or counter-clockwise, the position is looked for in which the camera runs most smoothly and quiet. This position is just a small segment of a screw turn.*

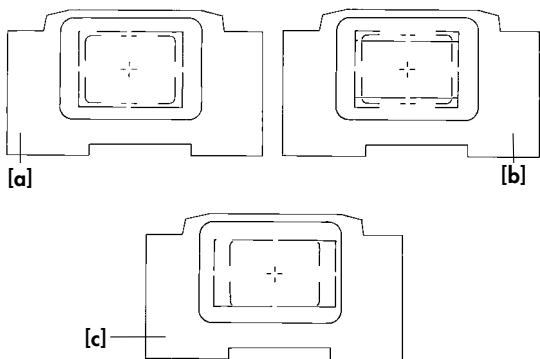

Fig. 124 – GROUND GLASSES

The MOVIECAM COMPACT is equipped with the same ground glasses as the MOVIECAM SUPERAMERICA. Ground glasses with the following markings are available:

STANDARD 35 formats:

- 1 : 1.375 (Academy)
- 1 : 1.375 + TV.....[a]
- 1 : 1.375 + (camera + projector)
- 1 : 1.375 + 1 : 1.66
- 1 : 1.375 + 1 : 1.75
- 1 : 1.375 + 1 : 1.85
- 1 : 1.66
- 1 : 1.66 + TV
- 1 : 1.66 + 1 : 1.85
- 1 : 1.66 + 1 : 1.85 + TV
- 1 : 1.85
- 1 : 1.85 + TV[b]
- 1 : 2.35 (scope)

SUPER 35 formats:

- Superscope 35
- Superscope 35 + TV
- Super 1 : 1.85
- Super 1 : 1.85 + TV.....[c]

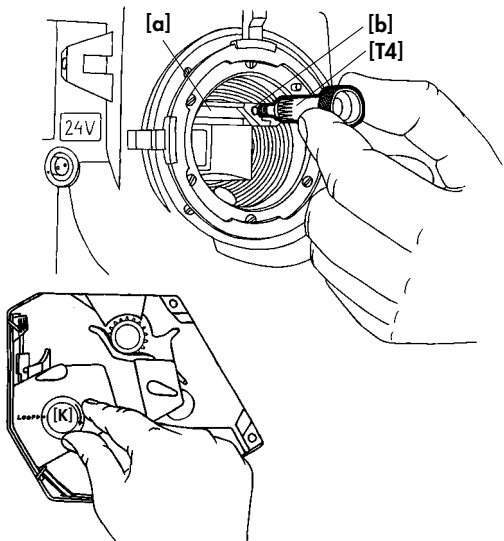

Fig. 125 – GROUND GLASS

The GROUND GLASS **[a]** of the MOVIECAM COMPACT lies flat on top of the mirror shutter and has a metal holder with a thread **[b]** in the right front corner.

Use the MOVIECAM COMBITOOL **[T4]** to exchange the GROUND GLASS as follows:

1. Disconnect the camera!
2. Open the camera door. Turn the inching knob **[K]** to clear the mirror shutter out of the way.
3. Screw the MOVIECAM COMBITOOL into the metal holder.

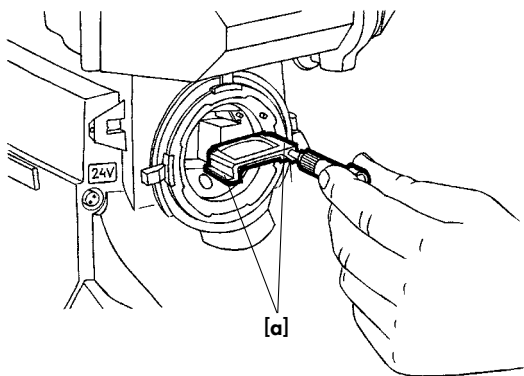

Fig. 126 – GROUND GLASS

When the **COMBITOOL** sits tight, pull out the **GROUND GLASS** *gently*.

4. Clean the **GROUND GLASS** gently with a brush or vacuum cleaner.

**Caution: Do not touch with fingers or a solid object!
Do not moisten or wipe!**

5. When screwing the **COMBITOOL** in or out, hold the ground glass holder **[a]** only.

6. Push the **GROUND GLASS** *gently* all the way in *until it rests against the stop* and unscrew the **COMBITOOL**.

**Caution: Never place the ground glass on its edges.
Do not force!**

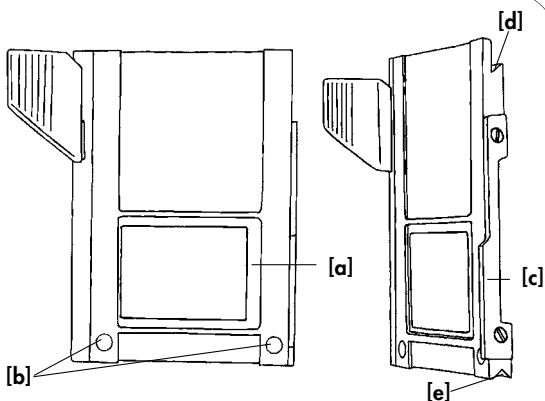

Fig. 127 – UPPER APERTURE PLATE

Film gate with gate matte is integrated in the UPPER APERTURE PLATE. Four APERTURE PLATES are available:

- 1 : 1.33 Full aperture
- 1 : 1.375 Academy
- 1 : 1.66
- 1 : 1.85

These APERTURE PLATES are made of extremely hard material; the film touches the plate only in the perforation area. To avoid deposits, e.g. hairs or film dust, the fine gate matte [a] in the UPPER APERTURE PLATE is slightly recessed. The openings [b] for the registration pins are located left and right of the gate. A side guide rail [c] is attached to the aperture plate right side. Clean the aperture plate **carefully** and **regularly** – best with a vacuum cleaner. Only when it is badly smudged – which will rarely be the case when handled meticulously – should you clean it very carefully with a small brush or an orangewood stick.

Caution: Never ever lubricate the aperture plate!

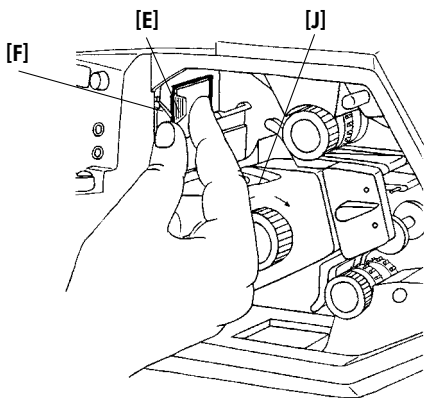

Fig. 128 – UPPER APERTURE PLATE

The image plane is located between the UPPER and LOWER APERTURE PLATE and the front film guide.

Both APERTURE PLATES are attached to notched brackets. For mounting, the UPPER APERTURE PLATE has V-shaped notches at its top **[d]** and bottom **[e]** edges (see page 149). These notches must be absolutely clean to make sure the UPPER APERTURE PLATE can be seated properly.

The V-shaped bottom edge of the UPPER APERTURE PLATE, seated on the rail (**[X]** on page 144) is held by a spring loaded lever. When removing the UPPER APERTURE PLATE,

1. push back the movement by turning lever **[J]** clockwise,
2. lift the small lever **[F]** and pull out UPPER APERTURE PLATE by its handle **[E]**.

Caution: Be careful not to damage aperture plate or gate – this might have serious consequences!

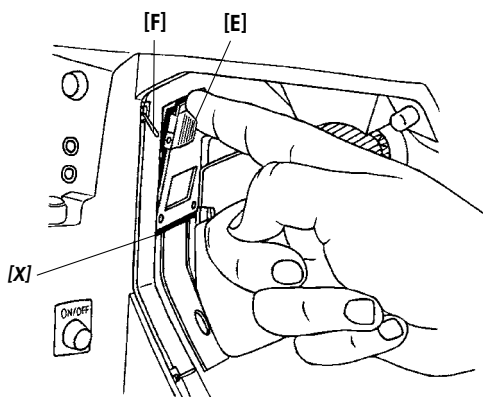

Fig. 129 – UPPER APERTURE PLATE

Mount the UPPER APERTURE PLATE on the rail [X] and press forward **gently** while lifting the **small lever [F]** and bringing it back to its resting position (= lock) again. You can insert the UPPER APERTURE PLATE only parallel to the rail [X]!

Caution: In case the aperture plate is slanting, start inserting again.

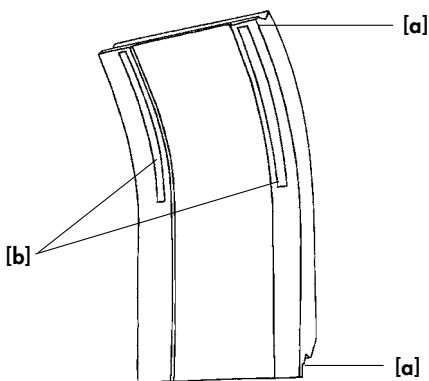

Fig. 130 – LOWER APERTURE PLATE

Like the UPPER APERTURE PLATE, the LOWER one also has V-shaped notches **[a]** at its top and bottom edges. The LOWER APERTURE PLATE has two slots **[b]** for the pulldown claws and some have a round window for any markings.

Notches, slots and surface of the APERTURE PLATE must always be clean – **check regularly**. Like the UPPER APERTURE PLATE, the lower plate is attached to notched brackets.

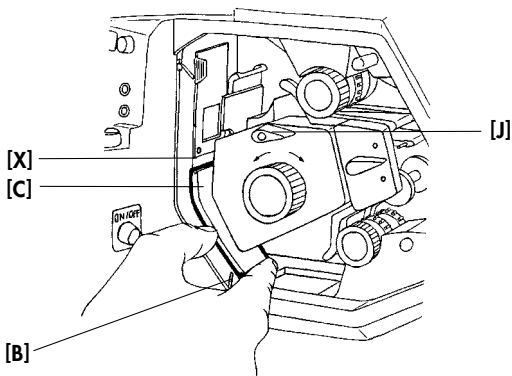

Fig. 131 – LOWER APERTURE PLATE

To remove the LOWER APERTURE PLATE:

1. slide back the movement block by turning lever **[J]**;
2. press the small lever **[B]** down;
3. hold the released APERTURE PLATE **[C]** at its base and remove it.

To insert the LOWER APERTURE PLATE, follow the steps described below:

1. Insert the LOWER APERTURE PLATE in the camera below the movement block;
2. pull LOWER APERTURE PLATE up and swing slightly toward camera front until it touches the rail **[X]**.
3. Simultaneously, pull down the small lever **[B]** and press the lower part of the LOWER APERTURE PLATE in.
4. Lock the LOWER APERTURE PLATE in the camera by releasing the spring loaded lever **[B]**.

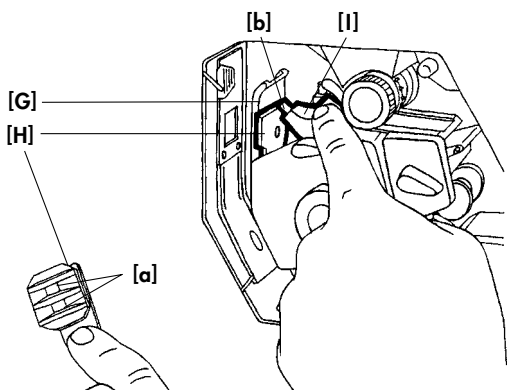

Fig. 132 – PRESSURE PLATE

In the center of the front film guide **[G]**, there is an opening for the PRESSURE PLATE **[H]**. This plate has two raised surfaces **[a]** that hold the film in the gate plane with a spring loaded pin. Smudged surfaces inevitably cause film scratches! To clean the pressure plate, remove it as described below:

1. Swing the pressure block **[I]** backward.
2. Lift and remove the PRESSURE PLATE.
3. Check PRESSURE PLATE and both surfaces thoroughly and – if necessary – clean them with lint-free cloth or orangewood sticks. Clean also the cavity at the rear of the PRESSURE PLATE.

The spring is pressed into this cavity. The spring loaded steel pin **[b]** in the pressure block presses the plate onto the film with a certain force. When tapped lightly, the pin should move easily and spring back to its former position.

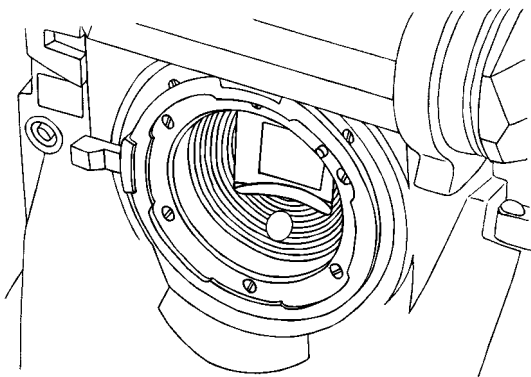

Fig. 133 – MIRROR SHUTTER

The opening angle of the mirror shutter ranges from 45° to 180°. To check or adjust the mirror shutter angle, proceed as follows:

- 1. **Important: disconnect the camera.***
- 2. Remove lens or cavity cap.*

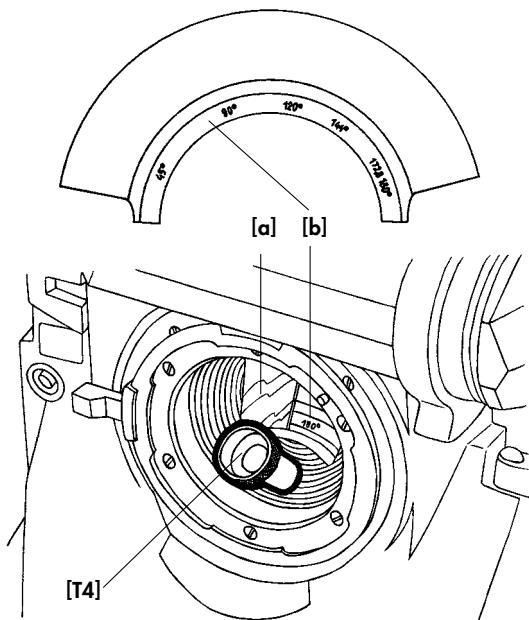

Fig. 134 – MIRROR SHUTTER

3. Advance mirror shutter **[a]** with inching knob **[K]** until shutter angle mark **[b]** is visible in the lens mount.
4. Insert the **MOVIECAM COMBITOOL [T4]** in the small opening below this mark and turn it until you get the desired mirror shutter angle marked on the scale **[b]**.

The mirror shutter has 6 positive stops for the following shutter angles:

45°, 90°, 120°, 144°, 172,8°, 180°.

Notes:

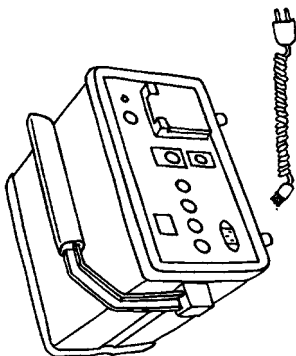
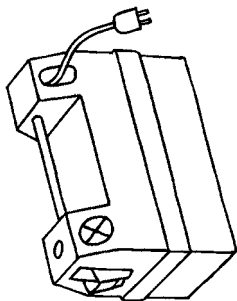
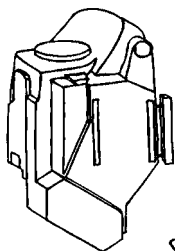
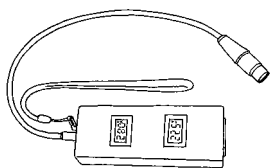

CHAPTER 8 THE POWER SUPPLIES

CHAPTER 8

THE POWER SUPPLIES

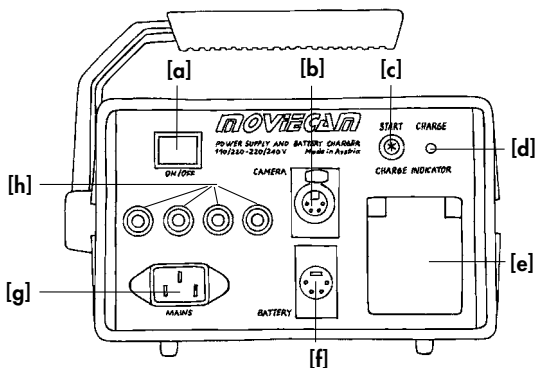

Fig. 135 – CAMERA POWER SUPPLY UNIT

- [a] Main switch
- [b] Camera supply 24 V / 8 A stabilized
- [c] Charge start button
- [d] Charger control LED
- [e] Plug socket 110 V or 220 V
- [f] Battery charger 24 V / 1,3 A
- [g] Connector 110 / 220 V – 50 / 60 Hz
- [h] Fuse
 - rear side 1 x 2 A glass fuse
 - front side 8 A automatic fuse
 - 2 A automatic fuse
 - 2 A automatic fuse
 - 2 A automatic fuse

The MOVIECAM COMPACT is operated with a constant voltage of 24 V. Under normal working conditions (approx. 25° C / color film in 1.000/300 MAGAZINE / 24 fps / READOUT / MOVIELITE / COLOR VIDEOCAMERA / COLOR ASSIST MONITOR, the camera consumes 2,5 A.

The BAT diode lights up in case the voltage drops below 20,5 V

The integrated, thermostatically controlled heating elements need approx. 20 W, even when the camera is not running.

The camera is powered either by the MOVIECAM POWER SUPPLY UNIT or a MOVIECAM BATTERY BLOCK.

A stabilized 24 V (direct current) outlet, a 110 V / 220 V (alternating current) outlet and a lead battery charger are integrated in the POWER SUPPLY UNIT.

Caution:

Prior to connecting the power supply unit with the mains, check the given voltage and, if necessary, adjust the selector at the power supply unit rear accordingly!

When the camera is connected, you can simultaneously charge a BATTERY BLOCK. You have to switch on the **main button [a]** of the POWER SUPPLY UNIT not only to operate the camera (switch lights red), but also when the POWER SUPPLY UNIT serves as battery charger. Charging needs approx. 4–6 hours and is indicated by a green diode **[d]** lighting up. It fades out when the battery is fully charged. Start charging by pressing the small **button charge [c]**.

Use the plug socket **[e]**, secured by a 2 A automatic fuse, to charge a second BATTERY BLOCK via its integrated charger or to supply e.g. an "Obie light" (max. 300 W / 220 V) or a video recorder.

At the POWER SUPPLY UNIT rear, there are the **voltage selector** and the glass fuse 2 A slow (5 x 20 mm).

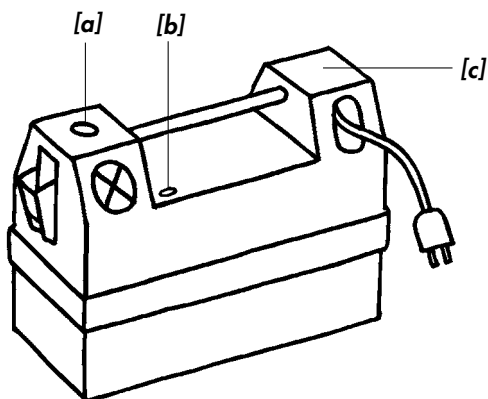

Fig. 136 – MOVIECAM BATTERY BLOCK

The 7 Ah 24 V DC MOVIECAM BATTERY BLOCK is an assembly of lead cells.

To charge, either connect the BATTERY BLOCK to the POWER SUPPLY UNIT charger or use the built-in charger.

The built-in charger [c] operates with 220 V.

Caution: Prior to operating the built-in charger with a different voltage, contact the rental house!

The green LED [b] lights up during charging period. After the BATTERY BLOCK has been fully charged, in approximately 6 hours, the charger switches off and the LED extinguishes.

To operate the MOVIECAM COMPACT, plug the red camera cable into the 24 V outlet [a].

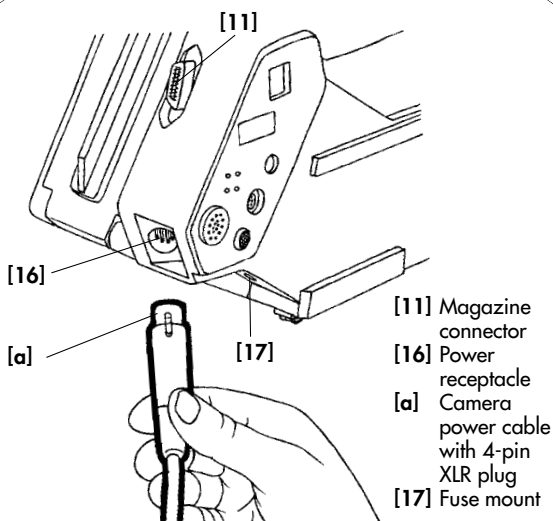

Fig. 137 – CAMERA POWER SUPPLY

MOVIECAM provides two special coiled cables: The blue cable connects the mains with the POWER SUPPLY UNIT. The red cable connects the POWER SUPPLY UNIT or a BATTERY BLOCK with the COMPACT.

*Both coiled cables may be stretched up to approx. 2,5m. **Do not overstretch!***

*As the voltage may drop up to 1 V per cable length (depending on the power consumption of the camera), **do not use a longer cable.***

The camera cable [a] can be easily plugged into the sloped connector [16].

The leverage caused by connector length and cable weight resp. strain might damage the socket attachment. Therefore it is recommended to protect it against tension, e.g. by attaching the cable at the fluid or geared head. Below the connector there is a fuse mount that can be removed with a screwdriver.

Glass fuse: 6,3 A slow, 5 x 20mm

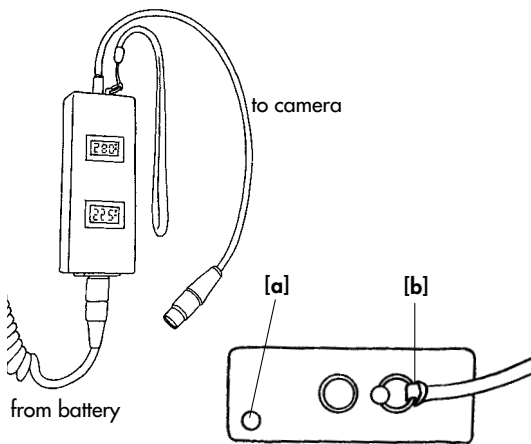

Fig. 138 – ADJUSTABLE VOLTAGE STABILIZER

The MOVIECAM DC-DC converter stabilizes the battery voltage to the maximum performance for the COMPACT.

The input range is 18 – 36 V dc

The output range is 24 – 28 V dc

The max. output power is 150 W.

Operation:

- 1. plug the battery cable to the power receptacle at the base of the unit,*
- 2. adjust the desired voltage, e.g. 24 V, by means of a 2mm screw driver introduced in the little hole on the top of the unit [a],*
- 3. connect the Adjustable Voltage Stabilizer to the camera,*
- 4. A strap [b] should help you securing the Stabilizer in order to prevent any restriction of the camera's and operator's movement.*

Notes:

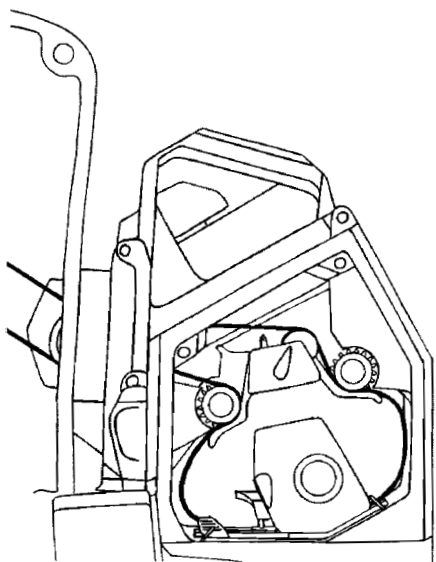
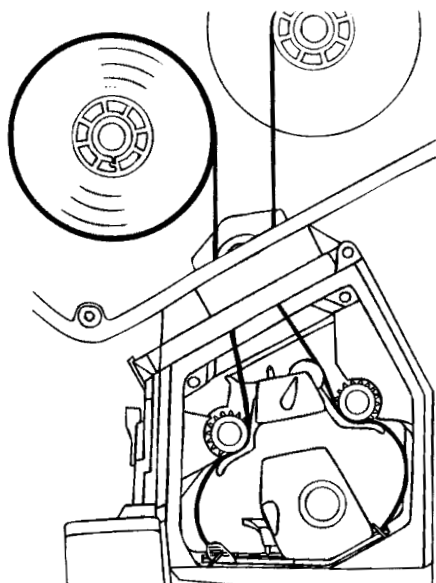

CHAPTER 9
THREADING FILM IN THE COMPACT

CHAPTER 9

THREADING FILM
IN THE COMPACT

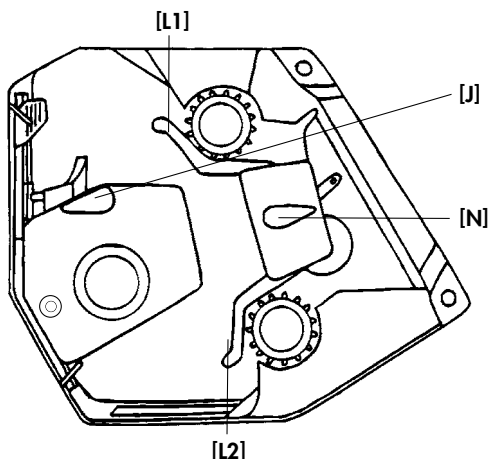

Fig. 139 – THREADING FILM IN THE CAMERA

1. *Open camera door.*
2. *Bring the movement to its rear position by turning the **lever [J]** clockwise.*
3. *Swing away the rear film guides **[L1]** + **[L2]** by lifting the **lever [N]**.*

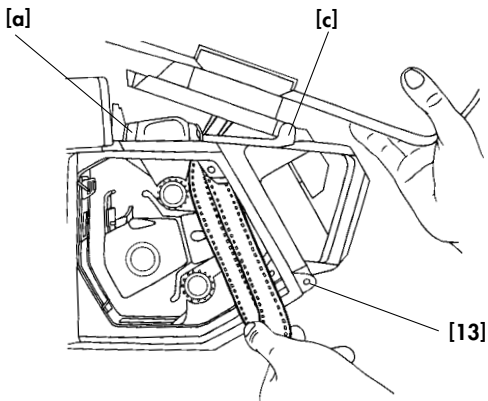

Fig. 1.40 – THREADING FILM IN THE CAMERA

4. Pull film loop (approx. 20cm / 8") out of magazine.
- 5a. With the TOP MOUNT ADAPTER:
Attach magazine mounting claw to the adapter mounting rail **[c]**. Insert film loop in camera.
- 5b. With the REAR MOUNT ADAPTER:
Attach magazine mounting claw to the camera body mounting rail **[13]**. Insert film loop in camera.
6. Grab the film loop and swing magazine forward toward camera body until it engages in the latch **[a]**.

Caution: The latch must be open! Do not crimp or fold the film!

Do not forget: Lock the magazine on the camera by turning the rear mount adapter locking lever clockwise or by pulling the top mount adapter locking lever forward.

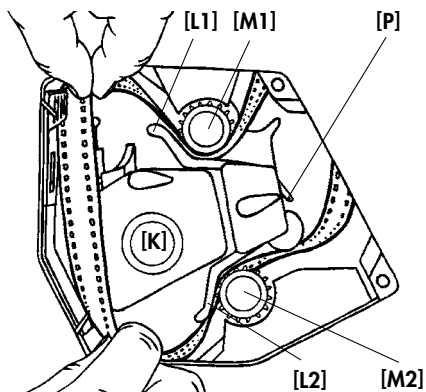

Fig. 141 – THREADING FILM IN THE CAMERA

7. Move film loop toward film gate and insert it between film guides [L1] + [L2] and sprockets [M1] + [M2].

Then thread film between aperture plates and movement block in a not too narrow loop.

Caution: As soon as you connect the camera, the film winders are shortly activated to tighten the film. Turning the inching knob [K] also activates these winders. To avoid this when loading film, just lift or lower the rear buckle switch [P].

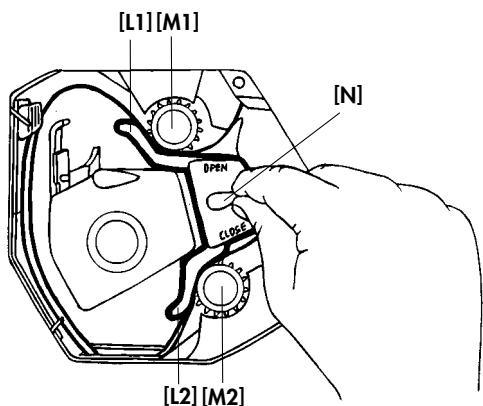

Fig. 1.42 – THREADING FILM IN THE CAMERA

8. Swing rear film guides **[L1]** + **[L2]** toward the sprockets **[M1]** + **[M2]** by lowering the lever **[N]**.

Caution: Sprocket teeth must engage properly in perforation!

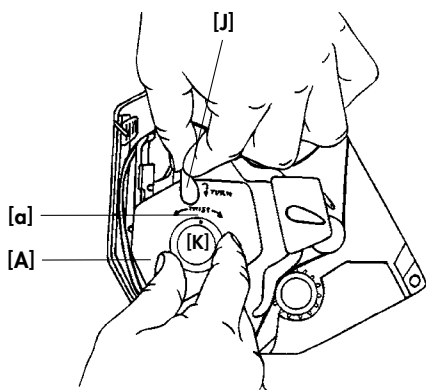

Fig. 143 – THREADING FILM IN THE CAMERA

9. Turn the **lever [J]** with one hand gently counter-clockwise to move the movement block **[A]** into its front position.

Simultaneously, turn inching knob **[K]** with the other hand to the left and right within the range of the **twist mark [a]** to engage the pulldown claws gently **and properly** in the film perforations. Only then lock the movement block by further turning the **lever [J]** counter-clockwise until it engages in its front position.

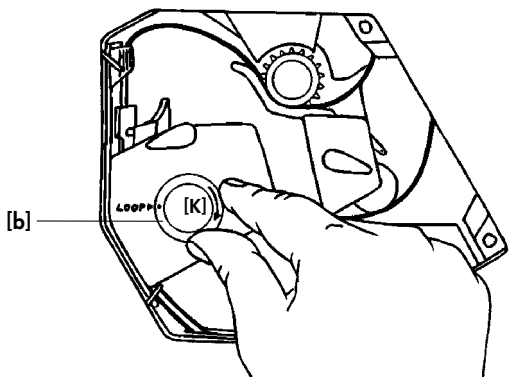

Fig. 144 – THREADING FILM IN THE CAMERA

10. To adjust loop length, turn inching knob [K] to the position (dot) marked LOOP [b].

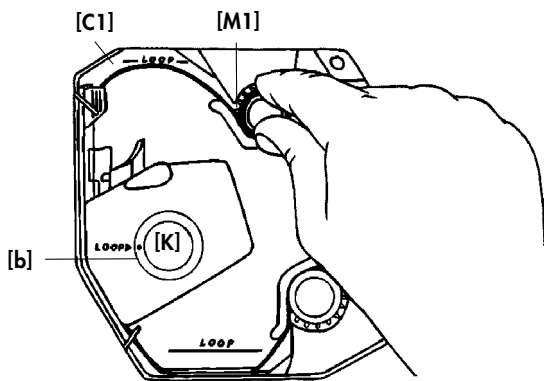

Fig. 145 – THREADING FILM IN THE CAMERA

11. Form upper film loop to the LOOP mark [C1] engraved on the rear side of the camera interior by depressing and turning the sprocket button [M1].

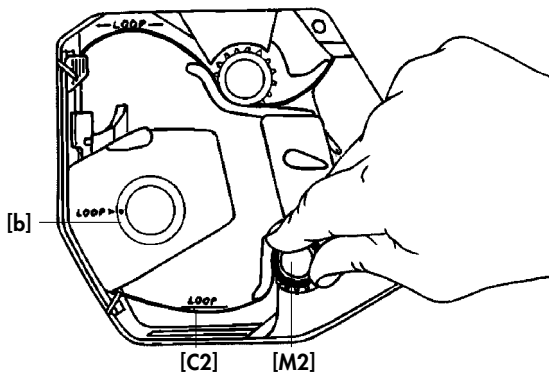

Fig. 146 – THREADING FILM IN THE CAMERA

12. Repeat this procedure with the lower film loop **[C2]** + **[M2]**.

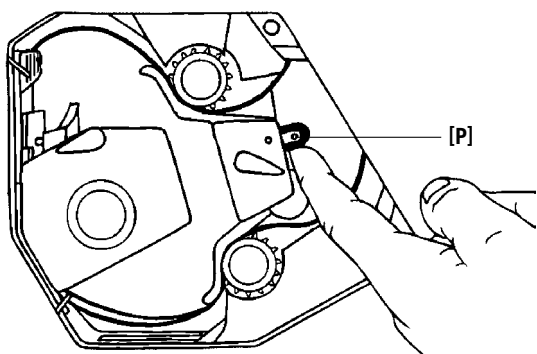
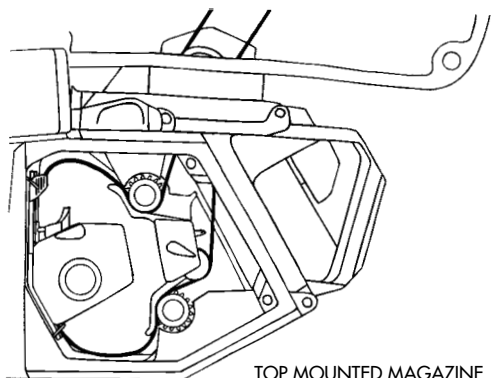
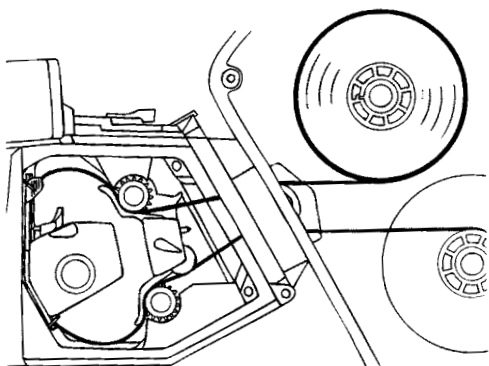

Fig. 147 – THREADING FILM IN THE CAMERA

13. Turn the buckle switch **[P]** to its center position and check film transport by turning the **inching knob [K]**. Film should always be tightened now by the winders. If not, check that the **locking levers and buckle switches** are in the shooting position.



TOP MOUNTED MAGAZINE



REAR MOUNTED MAGAZINE

Fig. 148 – THREADING FILM IN THE CAMERA

14. *To conduct a test run, run camera shortly at its regular frame speed.*
15. *When closing the camera door, care should be taken that the camera interior is clean and the **door lock** is flush with the door.*

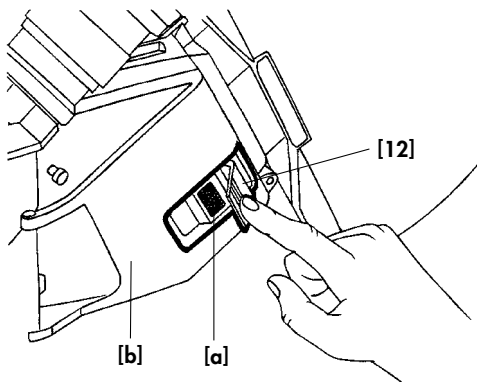

Fig. 149 – CAMERA DOOR AND LOCK

A **lever [12]**, attached with a **velcro strip [a]**, locks the camera door **[b]**. Move the **lever** toward the door until it is flush with the door. The **velcro** has to be absolutely clean; otherwise the **lever** – and thus the door – might open accidentally.

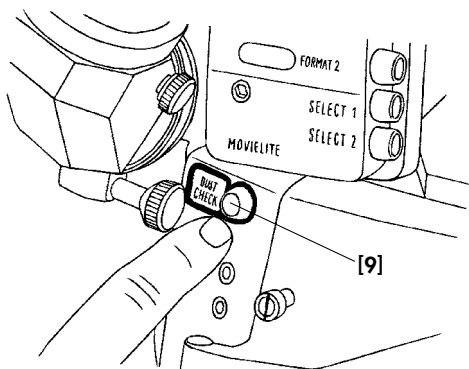

Fig. 150 – DUST CHECK

When manually switching off the camera, the electronic system of the MOVIECAM COMPACT automatically sets the mirror shutter to "viewing position". To inspect the gate without opening the camera, set the mirror shutter to shooting position by pressing the **dust check knob [9]**. Inspect the gate by either shining a flashlight through the lens or removing the lens. By pressing the **dust check knob**, the letters **dc** are displayed on the camera control board and the READOUT resp. REMOTE CONTROL BOX. The camera can then be switched on only after pressing the **dust check knob** once again, which sets the mirror shutter to "viewing position".

Caution:

Before cleaning the film gate (with great care!), disconnect the camera to prevent possible accidents or damage.

When the camera is connected again, the electronic system is automatically reset ("stand by" mode); the mirror shutter, however, remains in the shooting position and can be moved by either pressing the dust check knob or switching on the camera.

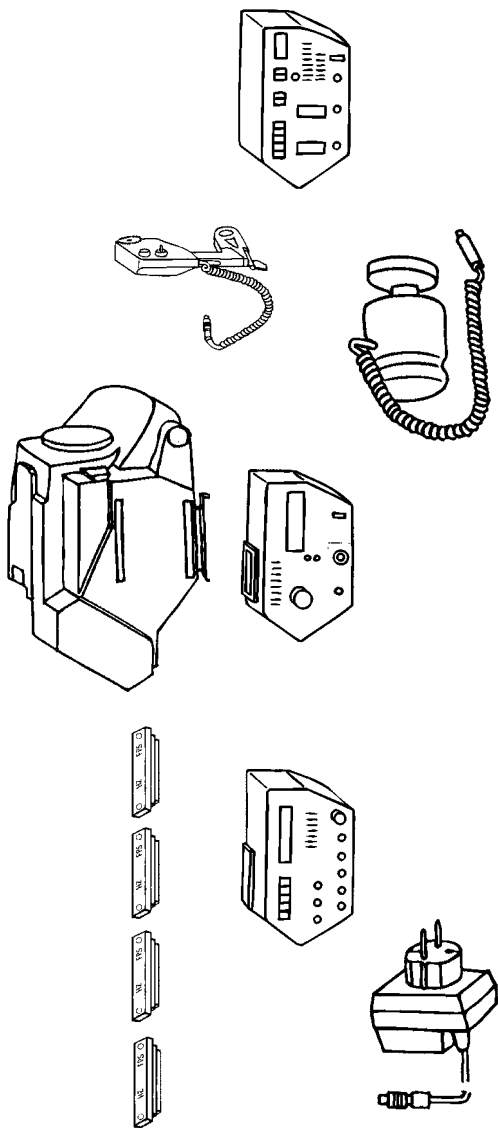

CHAPTER 10
THE ACCESSORY BOXES AND IRIS CONTROL

CHAPTER 10

THE ACCESSORY BOXES AND IRIS CONTROL

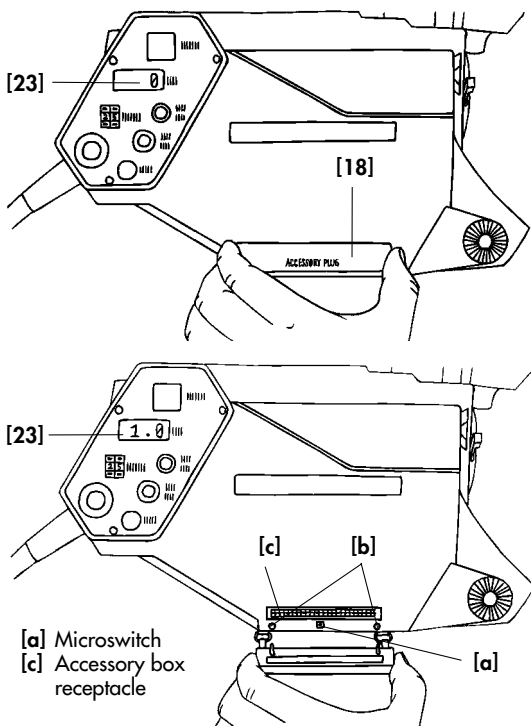

Fig. 151/152 – ACCESSORY PLUG

MOVIECAM provides three ACCESSORY BOXES for the COMPACT that can be mounted to the camera right side after removing the cover plate "accessory plug" [18]. When no ACCESSORY BOX is mounted, the accessory plug **must** be covered by this cover plate. If this is not the case, the fps display [23] of the control board and the READOUT or REMOTE CONTROL BOX will read [1.0] instead of [0] (= stand-by camera), and you cannot run the camera. This warning is activated by a microswitch [a] under the accessory plug cover.

When mounting the **cover** again, care should be taken that both locating pins **[b]** engage easily in the gauged boreholes. When the cover sits tight on the camera body, the display is reset to **0** and the camera is ready for operation.

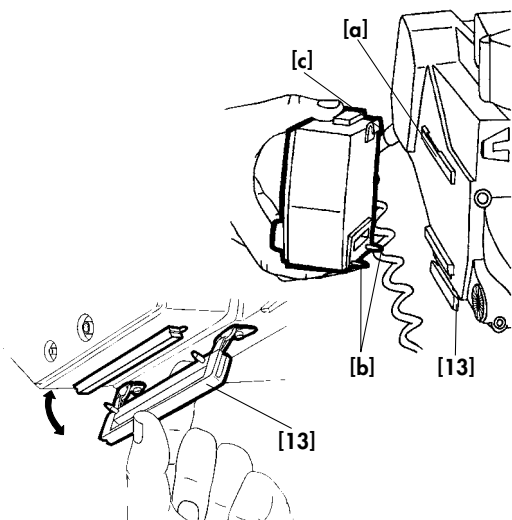

Fig. 153/154 – ACCESSORY BOXES

As usual when mounting any “electronic” accessory, disconnect the camera! Remove the accessory plug cover **[13]** which is then held to the camera body by two small cords. Attach the ACCESSORY BOX with the **latch [c]** to the upper rail **[a]** and swing it toward the camera until the connectors pop into place. This rail at the bottom serves as additional fixing device for the boxes and at the same time helps to prevent the sometimes occurring rattle of the accessory plug cover hanging on woven ribbons. As soon as an ACCESSORY BOX is mounted to the camera, the cover is put onto the new rail and thus fixes the box.

SPEED CONTROL AND SYNCHRONIZATION

The drive of the MOVIECAM COMPACT has an integrated crystal control with a tolerance smaller than $\frac{1}{4}$ of the image height per 1000 ft film roll.

This crystal controls all film speeds from 12 to 32 fps. Inputs outside this range are signalled by either **12** or **32** flashing in the display on camera and READOUT resp. REMOTE CONTROL BOX.

As long as the camera is not running with the preset frame speed, e.g. during its start-up (approx. 1,3 sec. to 24 fps), the **Sync warning light** blinks on the READOUT or REMOTE CONTROL BOX. According to the requirements, the camera can be controlled either with the integrated crystal control or with an external device.

SYNCHRONIZATION

Example 1:

Synchronization with an audio tape recorder

When the audio tape recorder has its own crystal control, both devices work synchronously. When the MOVIECAM COMPACT is controlled with an external sync signal, the audio tape recorder also has to be controlled with this signal. A PILOT CABLE connection is necessary between camera ("Fischer" connector **syncout** on the camera control board) and audio tape recorder.

Tip:

When collecting the camera equipment, it is recommended to take also a MOVIECAM.

PILOT CABLE with "Fischer" and "Binder/ Tuchel" (for NAGRA) connector.

Example 2:

The possibility of synchronizing the MOVIECAM COMPACT with TV and computer screens is limited when no cable connection or accessory is used!

Handling:

Choose frame speed: with a frequency of 50 Hz – 25 fps, with 60 Hz – 30 fps.

*Switch on the film-loaded camera and shift the image separation bar on the TV or computer screen toward the bottom of the viewfinder image by pressing the **t.up/bar** button ([25] on the control board (fig. 6, page 21)). As long as the bar remains in this position, it is not visible on film.*

Caution:

Due to the relative instability of video signals, synchronizing the MOVIECAM COMPACT without accessory can only hold for some time. Longer “videosync” settings are difficult!

The sync setting without syncobox can not automatically be repeated; you have to re-adjust the phase position after each start.

Example 3:

Synchronization with a projector without cable connection.

Handling:

*Set the camera's frame speed to that of the projector, e.g. 24 fps. Run the camera and press the **t.up/bar** button until the projected picture appears in the viewfinder as dark as possible. Synchronization is given as long as both devices are switched on.*

Precondition: projector with a stabilized drive.

Example 4:

Synchronization at a frame speed of 24 fps with discharging (pulsating) lamps, e.g. HMI lamps, with a frequency of 50 Hz is not possible.

By closing the mirror shutter to $172,8^\circ$, however, the flickering is reduced so that it is hardly discernible any more.

Recommendable combinations:

60 Hz	144°	24 fps
50 Hz	$172,8^\circ$	24 fps
48 Hz	180°	24 fps
50 Hz	180°	25 fps

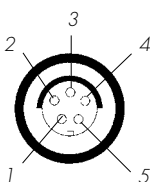

FISCHER D 103 A 054
female Top View

- 1 SELECT PILOT
NC-50 Hz
GND-60Hz
- 2 CLAPPER for NAGRA
- 3 TRP/ 1,7 m SEC
- 4 PILOT (5V AC, PEAK-PEAK)
selectable
50Hz at 25 FPS, 24 FPS
60 Hz at 24 FPS
- 5 GND (Ground, Return for Pilot)

CAMERA CONTROL PANEL/SYNC OUT

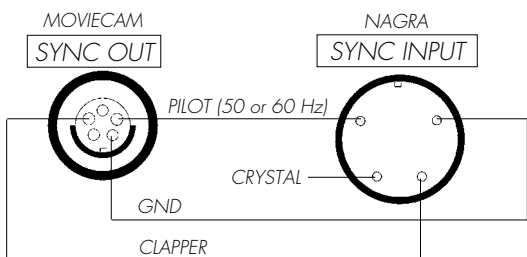

Plug type: FISCHER S 103 A 054 male BINDER 680-1-9-0309-00-04 Bottom view male

MOVIECAM PILOT CABLE FOR NAGRA IV PLUG

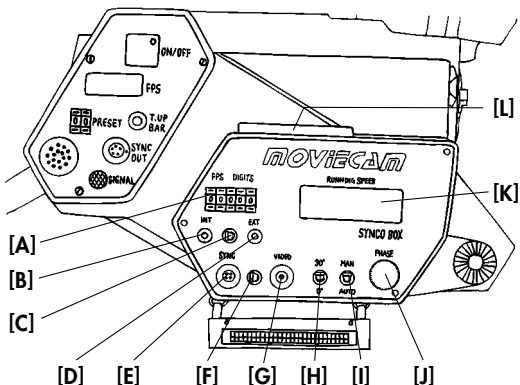

Fig. 1.55 – THE SYNCBOX

Apart from an exact and repeatable synchronization of the MOVIECAM COMPACT with video and computer images, the camera may also be synchronized with generators, other film cameras, front and rear projectors etc. The SYNCBOX can process any 5 V SYNC signal (TTL) or video norm signal (1 Vpp). The frame speed input at the control board and the crystal control of the MOVIECAM COMPACT are inactivated by mounting the SYNCBOX.

Caution: Mount the syncobox to a disconnected camera only!

[A] Fps digits – control board

This input unit allows to choose a frame speed with an accuracy of 0.001 fps.

[B] INT display

Crystal control of the MOVIECAM COMPACT is indicated by the red INT diode.

- [C] INT/EXT switch**
Change between internal crystal control and an external control with this switch.
- [D] EXT display**
The green diode EXT lights up when an external SYNC signal controls the camera.
- [E] SYNC connector**
Various external synchronization devices, e.g. MAINS SYNC ADAPTER, are attached here.
- [F] SYNC/VIDEO switch**
Use this switch to change between SYNC signal and VIDEO-SYNC signal.
- [G] VIDEO connector**
To control the camera, a SYNCBOX board separates the SYNC signal from the VIDEO signal.
- [H] 0°/90° – switch**
Use this switch to turn the phase 90°.
- [I] MAN/AUTO switch**
Use this switch to choose between automatic and manual phase setting.
- [J] Phase shift rotary knob**
Needed to manually synchronize the phase position of the mirror shutter with an external phase.
- [K] Running speed display**
The five-digit running speed display shows the actual frame speed of the running camera with an accuracy of 0.001 fps.
- [L] Stick-in module connector.**

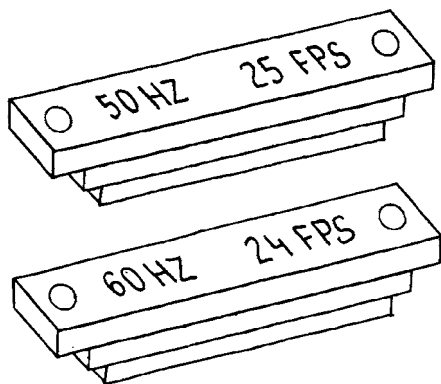

Fig. 156 – STICK-IN MODULES

In a slot on top of the SYNCBOX, there is a connector [L] for modules – see figure 154 – that are stuck into the box and fixed with two M 2,5 screws. You may choose between the following nine modules to synchronize the MOVIECAM COMPACT for the various applications:

- 24 Hz – 24 fps
- 25 Hz – 25 fps
- 30 Hz – 30 fps
- 48 Hz – 24 fps
- 50 Hz – 25 fps
- 60 Hz – 24 fps
- 60 Hz – 30 fps
- 72 Hz – 24 fps
- 75 Hz – 25 fps

According to the local frequency, the suitable module, e.g. 60 Hz, and then the frame speed, e.g. 24 or 30 fps, are chosen.

Caution:

Only the modules with the red engraving are suitable for the (new) syncobox provided with a display.

The digits 1.0 on the camera display indicate that the syncobox is not attached firmly enough to the camera body.

The MOVIECAM mains sync adapter can be connected to either a 110 V AC or 220 V AC outlet without special setting.

Example 5:

Synchronizing the mirror shutter with the pulses of discharging lamps (e.g. HMI lamps) powered by a generator.

When HMI or fluorescent lamps are powered by a generator that is not crystal controlled, frequency variations might cause flickering. Therefore the mirror shutter has to be synchronized with the generator frequency. When using several generators, the mirror shutter is synchronized with the generator that is used to illuminate wide areas.

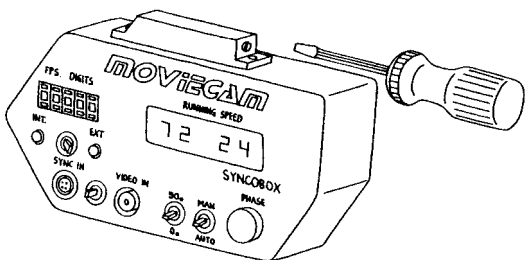

Fig. 156a – UPDATED SYNCBOX SOFTWARE AND NEW MULTIPLE REFERENCE MODULE

Novelty:

Beside the several stick-in modules programmed for one defined combination (Reference Hz/FPS), MOVIECAM now provides a MULTIPLE REFERENCE MODULE that makes working with the SYNCBOX easier.

This new module is flanged on the SYNCBOX instead of the "older" stick-in modules and allows to select the adequate combination by means of a 3 mm screwdriver.

Remark:

The new MULTIPLE REFERENCE MODULE is only usable with an up-dated SYNCBOX, a programmable device has already to be actualised by the rental house.

Use:

1. Feed in reference signal to the camera by connecting the external sync source using a cable plugged in the SYNC or VIDEO Connector on the SYNCBOX. For more detail see the pages dedicated to the SYNCBOX in the MOVIECAM COMPACT Users Guide.

2. Connect the camera to the power supply and the SYNCOBBOX-display shows a REFERENCE/SPEED (FPS) combination:
 - If the green LED on the SYNCOBBOX flashes: the reference does not match with the selected mode.
 - If the SYNCOBBOX green LED is on and the red LED is off: a reference signal reaches the SYNCOBBOX.
3. In order to select the suitable combination, turn the switch clockwise, **waiting two seconds in every position.**

Each time you change the switch position on the MULTIPLE REFERENCE MODULE – by carefully turning the little screw one step – a combination will be shown flashing on the display.

As soon as the red LED is off and the green one is on, the SYNCOBBOX will show the actual useful combination on the display.

COMBINATIONS:

The following 16 pre set steps are available by turning the little switch clockwise step by step.

Ref. Hz	Speed FPS
48	24
60	24
72	24
25	25
50	25
75	25
30	30
60	30

Ref.Hz	Speed FPS
24	24
70	35
100	25
50	25
50	25
50	25
50	25
50	25
50	25

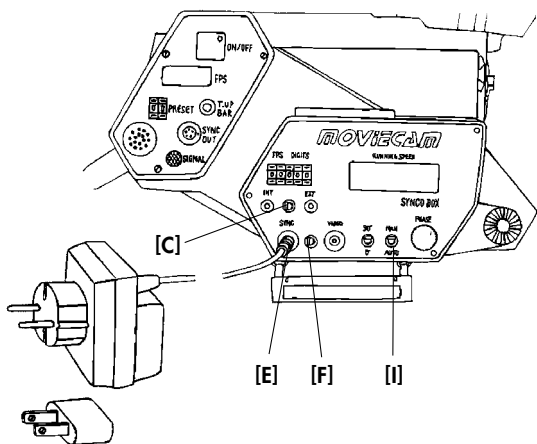

Fig. 158 – THE MAINS SYNC ADAPTER

The MOVIECAM MAINS SYNC ADAPTER scans the power frequency and its deviations. With a connecting cable (4-pin "Fischer" connector), the SYNC pulses are forwarded to the SYNCBOX (connector [E]).

Even when the camera is switched on and off, synchronization is maintained.

Handling: Disconnect camera from its power supply. Mount the SYNCBOX and connect camera again.

Set switch [C] to EXTERN.

Set switch [I] to AUTO.

Set switch [F] to SYNC.

Connect the MOVIECAM MAINS SYNC ADAPTER to the generator and the cable to the SYNC connector of the SYNCBOX. Set frame speed by choosing the stick-in module.

Caution: The camera has to be connected to either power supply unit or battery block. The sync pulses are used for synchronizing only!

Example 6:

Synchronizing the mirror shutter with TV/computer screens without cable connection between video recorder or computer and the MOVIECAM COMPACT.

*Synchronizing without connecting cable is possible due to the speed setting with an accuracy of 0.001 fps. When looking through the viewfinder of the running MOVIECAM COMPACT at the video image, the frame speed is set on the input unit **[A]** so that the image separation bar stops. This means that the frame speed is about one half or a third of the video frequency, e.g. 50 Hz – 25 fps or 72 Hz – 24 fps. An exact approach is possible due to the three decimals.*

*Then the bar has to be moved toward the lower corner of the viewfinder image by pressing the **t.up/bar button [25]**. The synchronization thus achieved is maintained as long as both devices are switched on. The synchronization can be repeated without manual readjustment only when a connecting cable is used (see example 7).*

Example 7:

Synchronizing the mirror shutter with TV/computer screens when connecting a video recorder or computer with the MOVIECAM COMPACT.

Handling:

Disconnect camera from its power supply.

*Mount SYNCBOX and connect camera again. Set switch **[C]** to **EXTERN**.*

*Connect the coax cable to the **video outlet**.*

Remark:

The VIDEO signal comes from the **video outlet** of e.g. a video recorder. In case a SYNC signal is used instead of a VIDEO signal (e.g. from a **sync out connector** of a video player or an inductive detector such as the MAGNETIC PICK UP UNIT), this signal is transmitted to the **sync connector**.

Set switch **[F]** to **video** or **sync**, depending on **the signal!**

Set switch **[H]** to 0° .

Set switch **[I]** to **auto**.

Point camera toward screen.

Feed the frame speed engraved on the STICK-IN MODULE with the five-digit keys **[A]**, e.g. 24.000.

Switch camera – even when not loaded – on.

The **auto function** of the SYNCBOX automatically guides the video image separation bar to the lower corner of the viewfinder image! This phase setting is automatically stored and used again when switching on the camera (e.g. after threading film), the video recorder or the computer.

This function is ensured even with battery-driven devices!

Caution:

The auto function may only be applied with frame speeds corresponding with one half of the sync frequency. With 48 Hz, for instance, the camera can run 24 fps, 25 fps with 50 Hz or 30 fps with 60 Hz.

In case the image separation bar is visible in spite of the **auto function**, switch to **man** and set the bar to the lower image corner by turning the **phase "shift" rotary knob [J]**. The switch **[H]** $0^\circ / 90^\circ$ may be useful here.

Handling:

Set switch **[H]** to 90°.

Set switch **[I]** to **MAN**.

Set the lower edge of the image separation bar into the center of the reticle by turning the **phase shift knob [J]**. Set switch **[H]** to 0° so that the bar is not visible on film.

Remark:

As long as the bar remains at the viewfinder image bottom, it is not visible on film.

Example 8:

Synchronization with sync pulses of a projector.

There are two synchronization possibilities:

Possibility A - Mains synchronization:

The projector drive is controlled by the frequency of the mains. By detecting the mains frequency, the MOVIECAM MAINS SYNC ADAPTER passes the pulse signals on to the camera.

Handling:

Disconnect camera from its power supply.

Mount SYNCBOX and connect camera again.

Connect the MOVIECAM MAINS SYNC ADAPTER to the mains and the SYNCBOX.

Set switch **[I]** to **MAN**.

Set switch **[F]** to **SYNC**.

Set switch **[C]** to **EXT**.

*Look through viewfinder at projector image and turn **phase shift rotary knob [J]** until the projected image appears darkest.*

Switching from 0° to 90° may be useful here.
Now synchronization between projector shutter and mirror shutter of the camera is achieved.
Remark: This setting can not be stored but is maintained only until one of the devices is switched off.

Possibility B – Sync pulses:

When the projector has a pulse generator (contacts at the mirror shutter) or a photo cell is installed in the projected beam, their pulses may be used as sync signals.

Handling:

Disconnect camera from its power supply.
Mount SYNCBOX and connect camera again.
Connect the projector's "sync cable" to the **sync connector [E]** of the SYNCBOX.

Set switch **[I]** to **MAN**.

Set switch **[F]** to **SYNC**.

Set switch **[C]** to **EXT**.

Look through viewfinder at projected image and turn **phase shift rotary knob [J]** until the projected image appears darkest. Then synchronization of the projector shutter with the camera mirror shutter is achieved.

Remark:

This setting remains stored even when the devices are switched on and off.

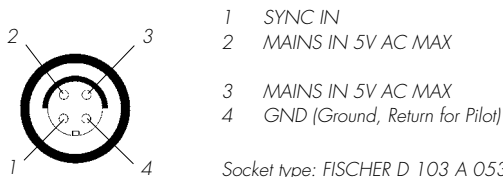

SYNC BOX SYNC IN (female) Top View

THE SPEED CONTROL

With the accessory SUPER SPEED CONTROL (SPEEDBOX for short), the following frame speeds with an accuracy of 0.001 fps can be chosen:

*forward filming 2 to 50 fps,
reverse filming 12 to 32 fps.*

*The specific acceleration – or deceleration – time within which the camera should change over to the next designated speed **fps 2** can be adjusted within the range from 1 to 99 seconds.*

*The SPEEDBOX can be very precisely programmed and may therefore be used to synchronize the camera with video and computer screens in case no SYNCBOX is available. The camera may be remote controlled with the SPEEDBOX via the connector **single frame**.*

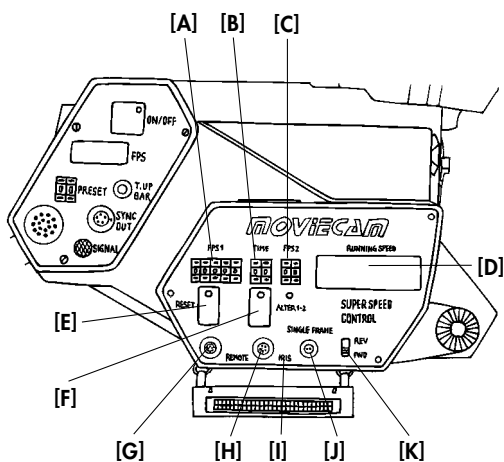

Fig. 158 – THE SPEEDBOX

[A] Fps 1 Input unit

The five-digit input unit allows programming a frame speed with an accuracy of 0.001 fps.

[B] Time – input unit

The two-digit input unit allows programming between 1 and 99 seconds.

[C] Fps 2 – input unit

The two-digit input unit allows programming a second frame speed between 2 and 50 fps (forward) and 12 and 32 fps (reverse filming).

[D] Running speed display

The five-digit display shows the actual frame speed of the running camera.

[E] Reset button

*This button reactivates the frame speed set with **fps 1**. As soon as the camera runs with the frame speed **fps 1**, the integrated red diode lights up.*

[F] Alter 1–2 button

*Switch the camera from **fps 1** to **fps 2** by pressing this yellow button. During the change from **fps 1** to **fps 2**, the integrated red diode lights up.*

[G] Remote socket

Attach the hand wheel MOVIESPEED REMOTE CONTROL to this socket. This inactivates the programmable time control.

[H] Iris socket

Analog voltage may be used for any lens iris remote controls.

[I] Alter 1–2 diode

*When this diode lights up, the camera has run up to frame speed **fps 2**.*

[J] Single frame connector

Attach to this connector various controls, e.g. timer, single frame system, PC (motion control) etc. When short-circuiting, e.g. with a button, the mirror shutter remains in the shooting position for four seconds while the displays of camera and READOUT resp. REMOTE CONTROL BOX shows sfr.

[K] Rew/fwd slide switch

Choose between forward and reverse filming with this slide switch.

Handling of the SPEEDBOX:

When using the SPEEDBOX to control the frame speed, feed the desired speed into the input unit **[A]** and set the slide switch **[K]** to the desired option. Reverse filming is indicated by the sign "minus" \ominus in front of each frame speed on the displays of camera and READOUT resp. REMOTE CONTROL BOX; **it is not indicated** on the SPEEDBOX.

Although the time and **fps 2** functions are not relevant in this case, the input unit time has to be set to at least 1 second, the unit **fps 2** between 2 and 50 fps. A frame speed outside the range of +2 to +50 fps or -12 to -32 fps will be indicated by flashing of either one of these numbers on the fps display **[D]**.

When the camera runs with frame speed **fps 2**, change to frame speed **fps 1** again by pressing the **reset button**. It is not possible to program the changing time from **fps 2** to **fps 1**; this is achieved in the shortest possible time.

If you switch the camera off after reaching frame speed **fps 2**, the system is automatically reset to frame speed **fps 1**. When activating the camera with one of the **on/off buttons**, the camera runs with the preset frame speed **fps 1**. Switch to the second frame speed **fps 2** by pressing the **alter button [F]**. As soon as the frame speed **fps 2** is reached, the diode **[I]** lights up.

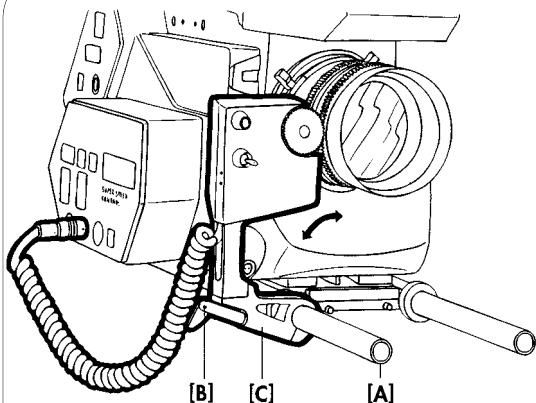

Fig. 1.59 – IRIS CONTROL

The IRIS CONTROL helps to automatically adjust the aperture to a programmed change of the shooting speed. Thus it is an accessory to the SPEEDBOX. The IRIS CONTROL is placed on the right SUPPORT ROD **[A]** such that its gear wheel can easily, but without being loose, be swung into the gear rim of the lens iris. The lever **[B]** serves to fix the system. In case a new ARRI base plate with 19mm Ø rods should be used instead of 15mm Ø rods (MOVIECAM BASE PLATE), fixing unit **[C]** of the IRIS CONTROL can be exchanged.

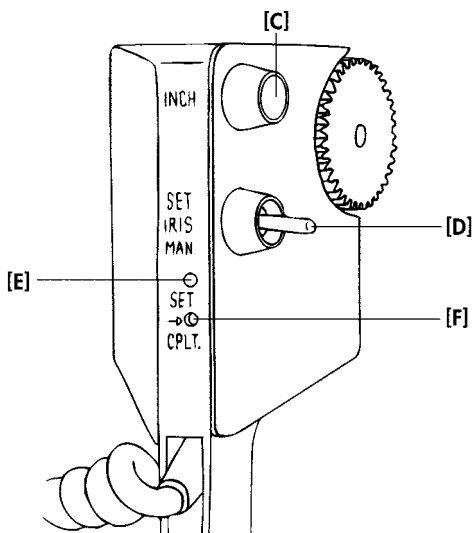

Fig 160 – IRIS CONTROL

After attaching the IRIS CONTROL to the SPEEDBOX, the camera is supplied with electricity. The LED **[E]** shortly lights up. Now the following procedure should be pursued:

1. Swing away IRIS CONTROL from the lens (decoupling of gear wheel).
2. Put lens aperture to "8".
3. Calibrate the IRIS CONTROL by pressing the INCH knob **[C]**.
4. Fence the gear wheel into the aperture gear rim.
5. Turn the gear wheel electrically with the help of the small flip switch **[D]** until aperture "8" has been reached exactly!
6. Operate Set switch **[F]** – for safety reasons only accessible through a 2mm hole – with the help of a sharp object (e.g. screwdriver, toothpick, pen).

7. The red diode **[E]** lights up.
8. Turn the gear wheel electrically with the help of the small flip switch **[D]** until an aperture value 3 steps higher or lower (2.8 or 22, depending on the lens) has been reached exactly!
9. Press Set switch **[F]** again.
10. Red LED **[E]** fades.
11. Adjust Speedbox to either of the two desired frame speeds (Speed 1 or 2).
12. Turn the gear wheel electrically with the help of the small lever **[D]** to the desired (measured) aperture value.

Example: Speed 1 = 24 fps Aperture 5.6
 or Speed 2 = 48 fps Aperture 4.0

Check:

When setting a different frame speed with the input unit of the SPEEDBOX, the aperture is automatically adjusted. This check is done when the camera is not operated.

Now the IRIS CONTROL is calibrated with the lens in use. This setting remains stored until the next calibration, even when the devices are removed and mounted again or are separated from the power supply.

Caution: The IRIS CONTROL only works with modern lenses where the aperture scale is linear!

WARNING:

The aperture ring must not be turned manually as long as the gear wheel of the IRIS CONTROL is engaged in the aperture gear rim of the lens!

Should the aperture be changed, the aperture gear rim can be operated manually after disengaging. The lock lever **[B]** allows quick pivoting of the IRIS CONTROL.

A new input is not necessary as long as the right aperture value is set when reengaging again. A check is recommended nevertheless. In case the LED starts flashing, a manipulation error has occurred; it can be eliminated by repeating the input steps 1 to 5. In case the LED continues flashing, which indicates a malfunction, the camera has to be disconnected for a while; thus the IRIS CONTROL software is reset.

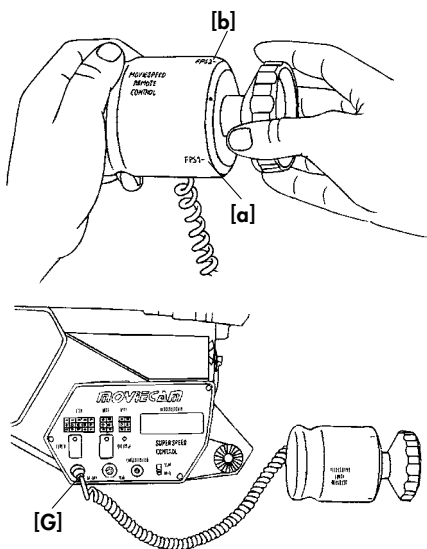

Fig. 161 – SPEEDBOX REMOTE CONTROL

When using the MOVIESPEED REMOTE CONTROL, both programmed frame speeds are automatically assigned to the marks 1 [a] and 2 [b] on the hand wheel. When using the hand wheel, the changing time is set manually which inactivates the timer. Unlike the programmable timer, the SPEEDBOX REMOTE CONTROL hand wheel permits to individually control the changing time from fps 1 to fps 2 and vice versa.

Important: Prior to starting the camera, turn the hand wheel to the position fps 1!

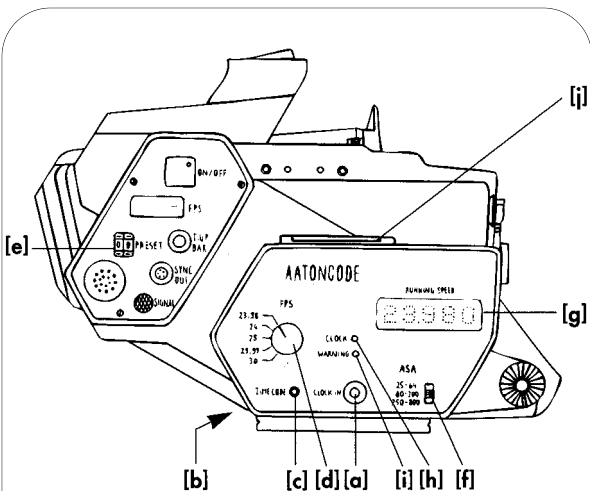

Fig. 162 – AATON CODEBOX

The code system AATONCODE, developed by the French camera manufacturer AATON, can be used together with the MOVIECAM COMPACT as of now. The AATONCODE, recorded on the film negative and the magnetic tape, helps to simplify various post-production tasks decisively. Examples: synchronization of film rushes with the magnetic sound tapes; identification of simultaneous shots with several cameras; film cutting; identification of film sequences transferred to video tapes and post-production work with video equipment; negative cutting and light and color matching.

Contrary to other code systems, the AATONCODE can be read by man (figures) as well as machine (SMPTE matrix).

During shooting, the AATONCODE is exposed onto the film in the MOVIECAM and at the same time magnetically recorded on the sound tape.

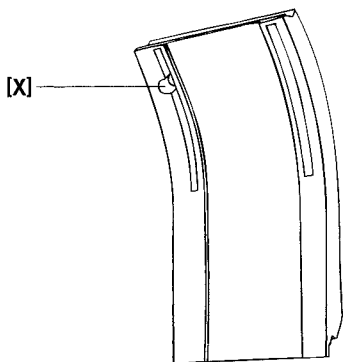

Fig. 163 – AATON CODE SYSTEM

MOVIECAM now offers an exposure module, and accessory box with the AATONCODE GENERATOR – the AATONCODE BOX – and a new LOWER APERTURE PLATE with exposure slot [X]. The exposure module, which is built in at the Vienna Headquarters only, consists of a two-row miniature matrix with seven yellow and seven red LED's and a projection lens.

AATON offers input (master) clocks, e.g. ORIGIN C or Cplus, as well as code generators for various tape recorders (e.g. NAGRA)

The AATONCODE BOX has the following connectors, control switches and displays:

Connectors:

[a] Front side: CLOCK IN, Lemo plug for connections with the AATON input clock.

[b] Back side: Connecting rail to the camera.

Control switches:

[c] Front side: TIME CODE, press button to choose the display.

[d] FPS, rotary knob to choose the frame speed.

Remark: When the AATONBOX is mounted, the input unit **[e]** on the camera body for choosing the frame speed is put out of operation.

[f] ASA, slide switch to input film sensitivity.

Displays:

[g] Fron side: RUNNING SPEED, five LED's indicate the frame speed

[h] CLOCK, green LED

[i] WARNING, red LED

[j] Top: eight-digit LCD display.

In order to use the AATONCODE correctly, the camera assistant will have to do various tasks.

Beginning the shooting day:

To be sure that the camera is equipped with the internal exposure module, attach the AATONBOX like any other MOVIECAM ACCESSORY BOX to the camera.

Then the camera is connected to its power supply.

If the message

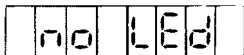

no LED

appears on the display of the AATONBOX, no exposure module is built in or it is not functional.

Furthermore, the LOWER APERTURE PLATE has to be equipped with an exposure slot.

The AATON input clock (Master Clock ORIGIN C or Cplus) is connected to the AATONBOX ("CLOCK IN" plug).

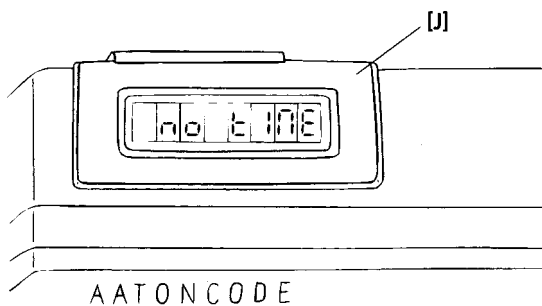
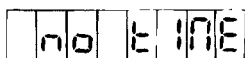

Fig. 164 – AATON CODEBOX

When the clock is connected for the first time, the red LED flashes and



Is displayed.

During initialization, which is started by pressing the [*] switch of the clock, the necessary information such as year, month, day, hour, minute and second is fed into the memory of the AATONCODE GENERATOR.

The clock display shows e.g. PRODUCTION#. Input of a digit (production number) serves to mark the production.

For the time being, further parameters, such as equipment numbers, can be programmed at the AATON factory only.

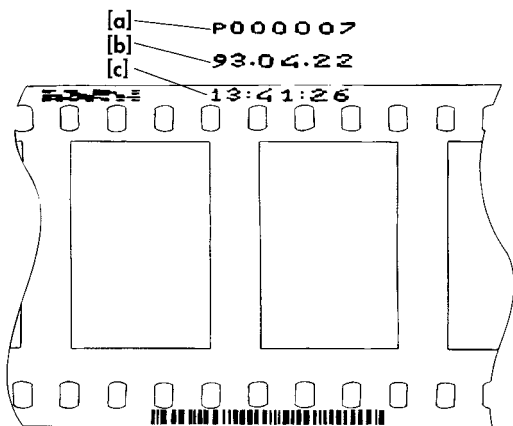

Fig. 165 – AATON CODEBOX

During shooting, the whole information is recorded onto the film.

Example: [a] = production number
[b] = date
[c] = time

After initializing, the following appears on the display of the clock:

GOOD
or
GOOD 00.0

In case an earlier "TIME" is still stored in the memory of the CODE GENERATOR, it will be displayed.

In case it is asynchronous to the actual "TIME", the message

BAD TIME

appears on the display.

Then the question

RELOAD?

appears. By again pressing the [*] switch of the clock, the actual "TIME" is recorded. After the new initialization, the message

GOOD

appears on the clock display. Only then can the input clock be disconnected.

Is an EBU Smpte Ltc signal used for initialization instead of the AATON ASCII input clock, this signal has to be transferred via the LEMO plug ("COLOCK IN" plug).

When the AATONCODE GENERATOR understands the signal, within approx. 10 seconds the message

LTC - IN

appears on the display of the AATONBOX for 1 second.

Initialization is done before shooting with the same input clock for all cameras and sound recorders.

Then the assistant puts the sensitivity of the negative film in use into the exposure unit by operating the "ASA slide switch" on the AATONBOX.

Initialization of the AATONCODE GENERATORS remains stored for approx. eight hours, unless the generators have been disconnected from the camera power supply for more than one hour and the temperature is not within the range from - 10°C to + 40°C. Thus AATON limits the crystal-accurate time guarantee to eight hours. After eight hours, the red LED lights up and the time display

HH=MM=SS

starts to flash.

Is the MOVIECAM, and thus also the AATONBOX, disconnected from its power supply for a short time (max. one hour), e.g. when changing batteries, the AATONCODE generator is supplied meanwhile by a buffer battery built into the AATONBOX. As long as the AATONBOX is connected to the powered MOVIECAM, the buffer battery is continually recharged.

During a power bridging with the buffer battery, both LED's flash and

5td-6488

appears on the display. 88 is the number of minutes for which the buffer battery guarantees operation. After 60 minutes, the built-in timer switches off the AATON GENERATOR; a new initialization is then necessary.

In order to avoid this, just connect the AATONBOX to the powered MOVIECAM for a short time; this results in a new countdown of the stand-by operating time. In the course of the shooting day, the camera assistant will check the synchronism of the AATONCODE GENERATOR with the input clock every four hours. Should the temperature fall below -10°C or rise above $+40^{\circ}\text{C}$, it is recommended to check the AATONCODE system more frequently. To do so, connect the AATONBOX with the input clock. By pressing the TIME CODE switch on the AATONBOX, an information appears on the display; by further pressing the switch, the next information appears. After initialization, when the camera is not operated, the first information

HH=MM=SS

appears on the display.

The green LED starts to flash as soon as the AATONCODE generator is ready for operation. The red LED has faded. When the green LED does not flash prior to shooting, the AATONCODE will not be recorded. The green LED will permanently light up during shooting.

During shooting, "II" is added to the time information:

HH MM SS II

II stands for the frame speed, e.g. **11093224** = 11 hours, 9 minutes, 32 seconds and 24 fps.

When the red LED lights up, something is wrong; it is then necessary to check the display.

The message "ERROR" appears when a jammer error occurs; for minor errors, the display message and the error message will flash alternately, each for one second a time.

Examples for error messages and further information: Should the actual frame speed deviate from the input speed, e.g. 24 fps, by more than $1/24$ seconds, the red LED will light with 10% of its brightness.

Furthermore,

SHIFT-X.X alternately with **HH MM SS II** will appear on the display. **X.X** is the deviation in $1/24$ (25, 30) seconds. This error must not occur when shooting with 24, 25 and 30 fps. For other frame speeds, this "error" has to be indicated. A minus (-) in front of the digit indicates too high frame speeds.

Further examples:

14=32=07 14 hours, 32 minutes, 7 seconds.

43030216 Production number = 43, year = 2003, month = February, 16th day.

CAM=0004 Camera with code generator No.4.
Remark: This number is programmed at the AATON factory and can so far not be changed by the user himself.

BAT=23,9 Power supply voltage = 23.9V. (The AATONBOX is powered by the power supply of the MOVIECAM).

BAT=11.9 Power supply voltage of the buffer battery = 11.9V, when the MOVIECAM is not connected to a power supply (stand-by operation).

Warning: When less than 10V are indicated, the buffer battery has to be recharged by connecting the AATONBOX to the powered MOVIECAM. Recharging time is approx. ten hours. During this time the MOVIECAM can of course be operated.

LO-ASA The emulsion sensitivity is between 25 and 64 ASA.

MED-ASA The emulsion sensitivity is between 64 and 200 ASA.

HI-ASA The emulsion sensitivity is between 200 and 800 ASA.

TC=22,6 The temperature sensor indicates 22.6°C

At 100% brightness of the red LED:

UNADJUST The generator is defective and can only be repaired at AATON.

At 100% brightness of the red LED:

NO TIME (flashing) The code has not been initialized; no code is recorded although the camera is running.

At 100% brightness of the red LED:

NO LED No code recording; the exposure unit is defective. Exposure module and connectors have to be checked at the rental house.

At 50% brightness of the red LED:

NO BAT The exposure unit is supplied by the buffer battery of the AATONBOX; camera voltage is too low. Check power supply.

At 50% brightness of the red LED:

LED R XX XX means the amount of defective red LEDs in the exposure module. Recording is continued with the help of the yellow LED. This is just an interim solution, the damage has to be repaired soon.

At 50% brightness of the red LED:

LED Y XX XX means the amount of defective yellow LEDs in the exposure module. Recording is continued with the help of the red LED. This is just an interim solution, the damage has to be repaired soon.

At 10% brightness of the red LED:

HH=MM=SS (flashing) Last initialization was done more than eight hours previously.

At 1% brightness of the red LED:

STD-BYXX The buffer battery has been operated for XX minutes.

By continuously pressing the display switch,

STOP ?

will appear on the display. By pressing the display switch again, the AATONCODE GENERATOR is switched off. This saves the buffer battery charge during a shooting break (or after a shooting day); when needed again, however, all devices have to be initialized again!

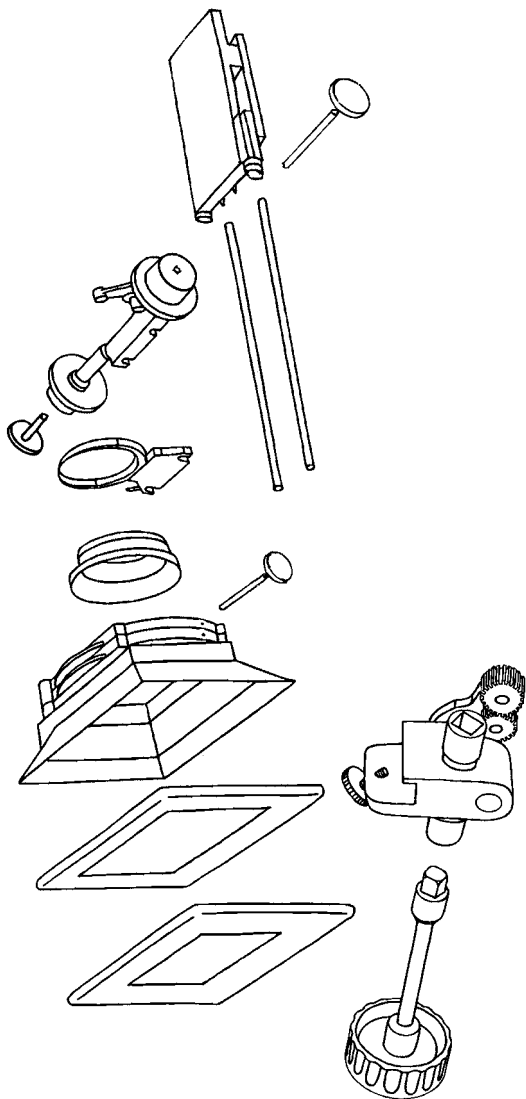

CHAPTER 11
SUPPORT, FOLLOW FOCUS AND MATTE BOX

CHAPTER 11

SUPPORT, FOLLOW FOCUS
AND MATTE BOX

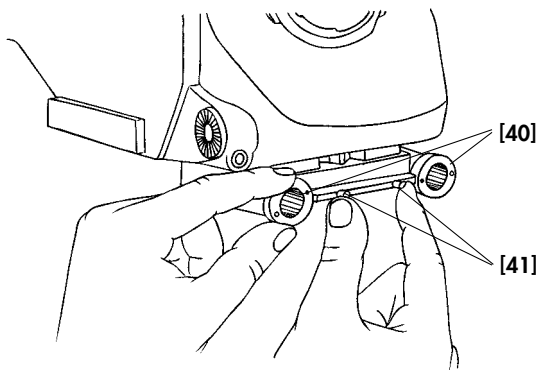

Fig. 166 – SUPPORT ROD BRACKETS

As centers and axes of the **STANDARD 35** and **SUPER 35** format are 1,27mm apart, it is not only necessary to change the film gate, but also to adapt viewfinder system, lens mount, lens support and matte box brackets when changing format.

Adjust the support rod brackets on the **BASE PLATE** to the format used by turning the two asymmetrical rings **[40]** (see also page 27). Press both sliders **[41]** toward the center and turn the rings so that each two dots of the same color face the center and the locating pins engage in the holes.

WHITE = **STANDARD 35** format
RED = **SUPER 35** format

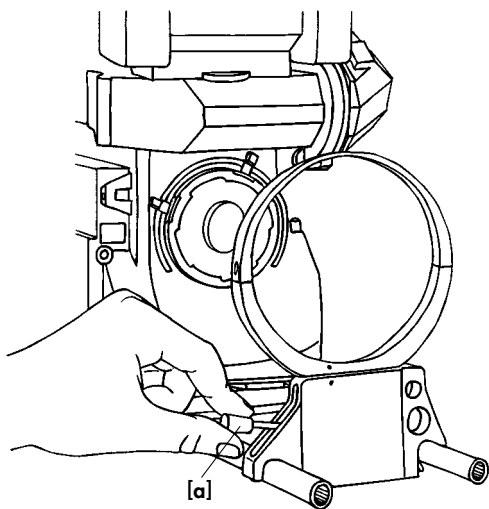

Fig. 167 – LENS SUPPORT

*Mount the LENS SUPPORT to both SUPPORT RODS and tighten it by lowering the lever **[a]**.*

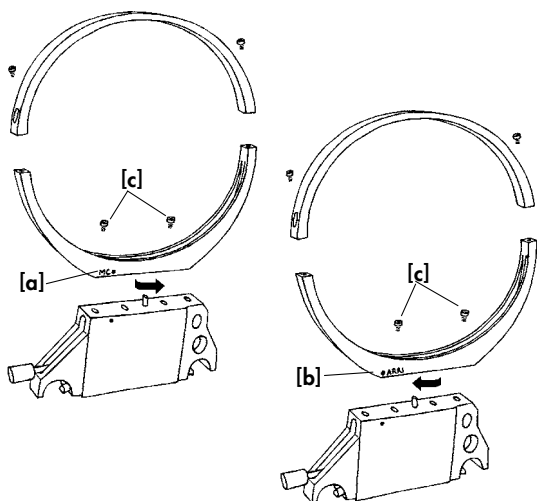

Fig. 168 – LENS SUPPORT

The MOVIECAM lens support can be adjusted to either MOVIECAM (MC) [a] or ARRIFLEX (ARRI) [b] standard .

The lower part of the support ring is attached asymmetrically and may thus be turned 180° after loosening the two M4 Allen fixing screws [c]. This shifts the ring's central axis to the center of the standard selected.

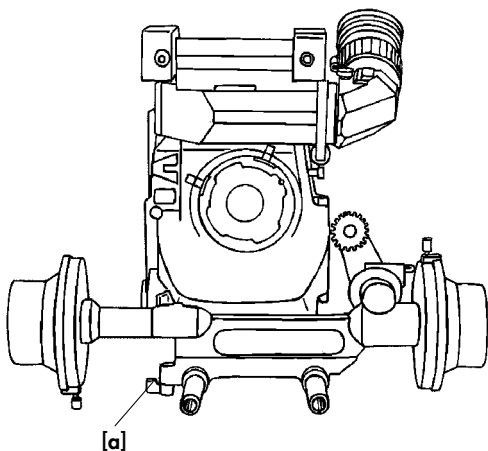

Fig. 169 – STUDIO FOLLOW FOCUS

*Slide the MOVIECAM FOLLOW FOCUS onto the SUPPORT RODS and tighten it with the lock lever **[a]**.*

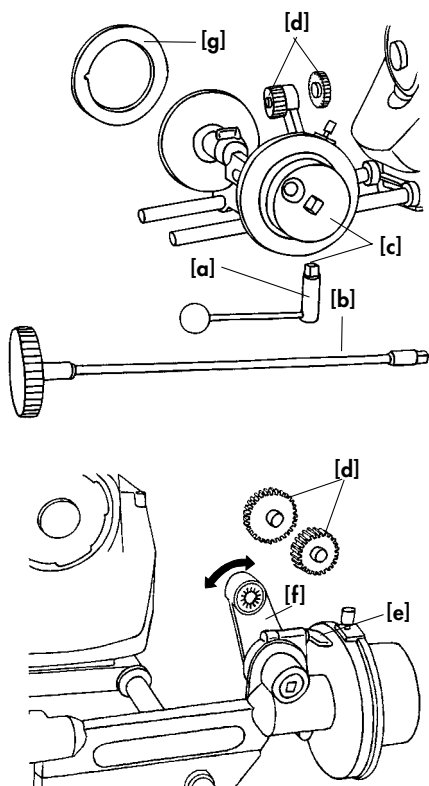

Fig. 170/171 – STUDIO FOLLOW FOCUS

MOVIECAM provides several accessories for the STUDIO FOLLOW FOCUS, e.g. focus extension levers **[a]** and flexible shafts **[b]** (easy to mount with a squared stick-in system **[c]**), as well as various gears **[d]** for the different lenses, e.g. COOKE, ZEISS, CANON, ANGENIEUX and MOVIELENS. Loosen the locking lever **[e]** and swing the small driver arm **[f]** toward the lens gear.

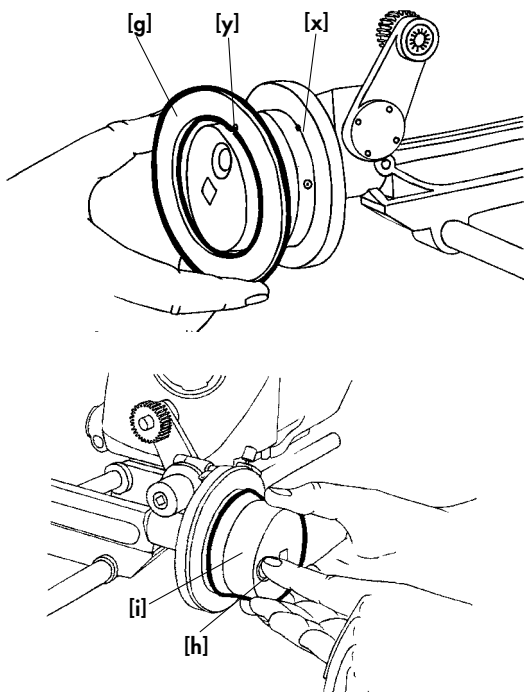

Fig. 172/173 – STUDIO FOLLOW FOCUS

For each lens, two magnetic disks **[g]** for individual marks should be available - one for each side of the FOLLOW FOCUS.

Caution: When attaching these disks, the locating pins **[x]** have to engage in the holes **[y]**.

The STUDIO FOLLOW FOCUS has a two gear drive. To change gear, press the small button **[h]** and simultaneously move the wheel **[i]** forward or backward.

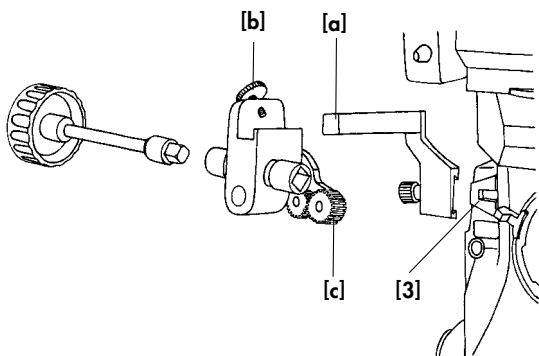

Fig. 174 – LIGHTWEIGHT FOLLOW FOCUS

*The MOVIECAM LIGHTWEIGHT FOLLOW FOCUS is used mainly for handheld operation. It has no scales; the distance has to be read directly off the lens barrel. After the squared support rod **[a]** is attached with a screw to the dove tail bracket **[3]** at the camera front, mount the LIGHTWEIGHT FOLLOW FOCUS to this rod. Fix it with the screw **[b]** until the gear **[c]** attached to the driver arm engages in the lens gear.*

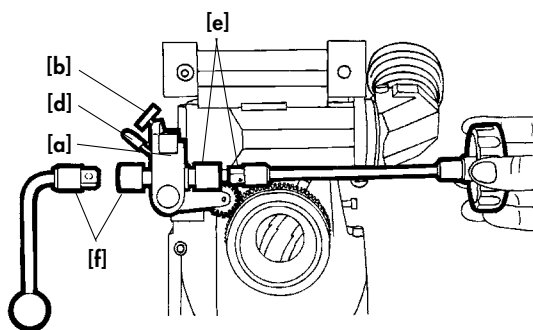
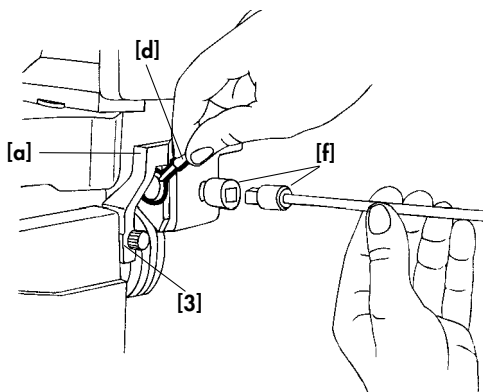

Fig. 175/176 – LIGHTWEIGHT FOLLOW FOCUS

The lever **[d]** at the rear of the LIGHTWEIGHT FOLLOW FOCUS is used to swing and adjust the small driver arm. A small gear, used for prime lenses (e.g. Zeiss), is attached to the end of this arm.

The operating wheels are attached to either left **[e]** or right **[f]** side of the follow focus.

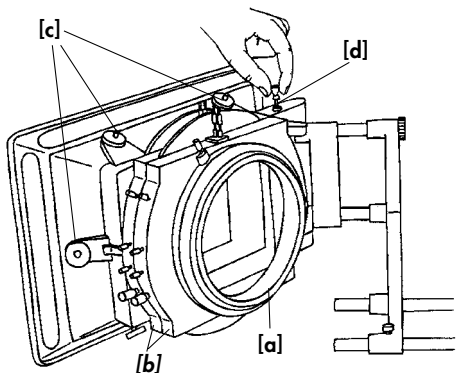

Fig. 177 – MATTE BOX

This MATTE BOX is equipped with two filter stages **[b]** for altogether four 6.6" x 6.6" filters, two each rotatable and sliding through, as well as two toothed filter frames, operable with a rotary knob or flexible shaft. The 4x filter stage has a receptacle **[a]** on the rear for 6", 138mm or 4 1/2" filter rings, as well as for reflex prevention rings **[e]** and an additional 4" x 4" filter stage. The 4x filter stage can be interchanged against other filter stages. The MATTE BOX can be swung open to the front for easy lens cleaning. By lifting the lever **[d]** on the top right side, unlock the MATTE BOX and swing it open to the front. After swinging it back, care should be taken that the lever locks into place again. Additional holders **[c]** on the MATTE BOX serve for fastening French flags.

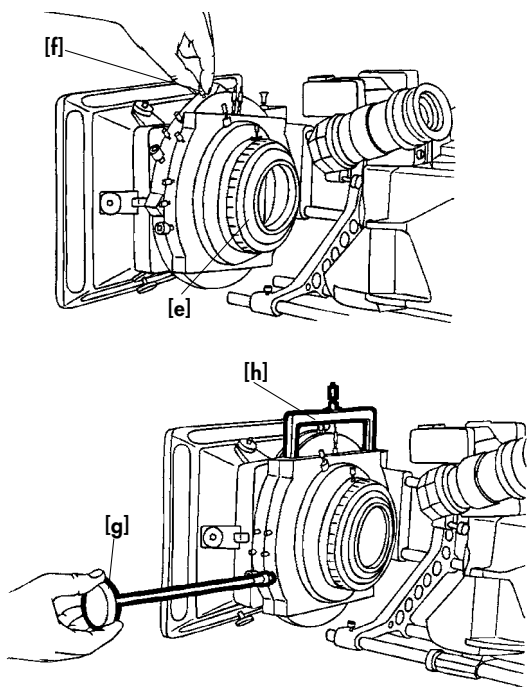

Fig. 178/179 – MATTE BOX

The MATTE BOX holds two filter stages for altogether four 6,6" x 6,6" filters, two each rotatable (knob **[f]**) and sliding. Each filter stage has an attachment at the rear for 6", 138 mm or 4 1/2" filter rings, rubber donuts (reflex prevention rings) **[e]** and an additional 4" x 4" filter holder.

Some filter stages have a gear drive that may be operated with the hand wheel **[g]** via a flexible shaft to move a toothed filter frame **[h]**.

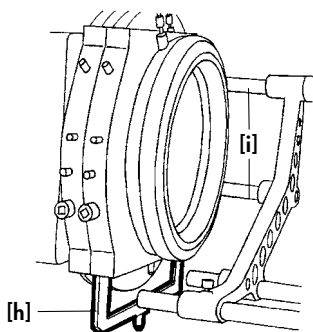
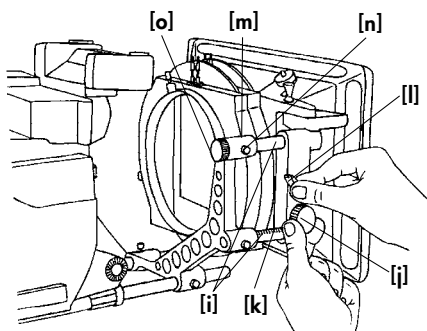
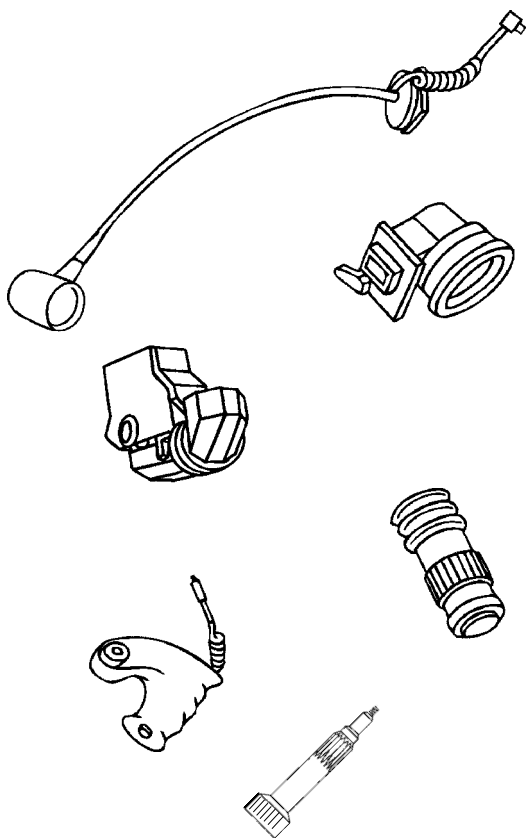

Fig. 180/181 – MATTE BOX

The MATTE BOX with its filter stages is attached mobile to two short rods [i]. The gear [j] engages in the toothed lower rod [k]. To move the MATTE BOX forward or backward without having to move the whole bracket, loosen the locking lever [l] and turn the gear [j]. The asymmetrical upper bracket [m] allows to adjust the MATTE BOX to the lens more precisely. Loosen the adjusting screw [n] and turn the knob [o] at the rear end of the upper rod.

Caution: When using graduate filters, care should be taken that the filter, when in its lower position, does not touch the rods.

Notes:



CHAPTER 12

MISCELLANEOUS
AND APPENDIX

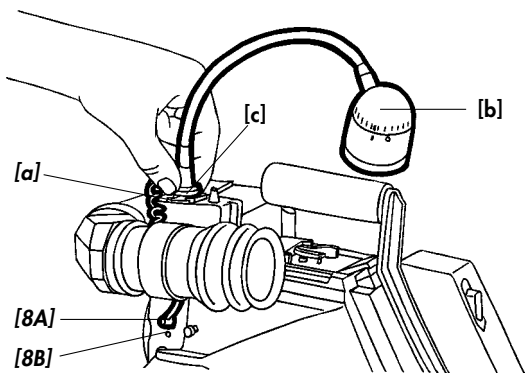

Fig. 182 – THE ASSISTANT WORK LIGHT

- [a] Work light shoe, bracket
- [b] On/off switch
- [c] Attachment screw
- [8A] [8B] Connectors

The ASSISTANT WORK LIGHT can be mounted either on the MOVIELITE or on the READOUT like a flash to a still camera.

After loosening the fixing screw, slide the light shoe into one of the several brackets **[a]** and tighten the screw **[c]**.

Disconnect the camera, then connect the short coiled cable (similar to that of the eyecup heater) to one of the two connectors **[8A]** or **[8B]** (see also page 16). The light is switched on by turning its cap **[b]**.

Always carry a spare bulb (24 V/4 W) with you.

Eyepiece heater and ASSISTANT WORK LIGHT may be used together (but keep an eye on your battery!).

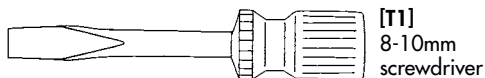

[T1]
8-10mm
screwdriver

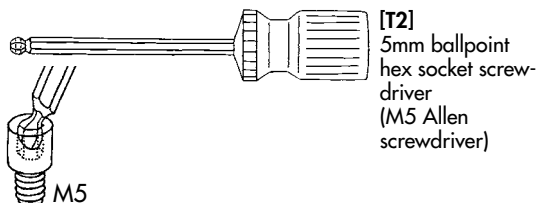

[T2]
5mm ballpoint
hex socket screw-
driver
(M5 Allen
screwdriver)

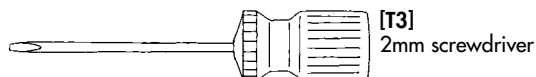

[T3]
2mm screwdriver

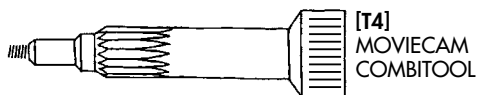

[T4]
MOVIECAM
COMBITOOL

Fig. 183 – TOOLS

In addition to the various cleaning tools, the camera assistant needs only four other tools to work with the MOVIECAM COMPACT.

*With [T1], you attach the BASE PLATE to the camera.
With [T2], you can mount and remove e.g.
VIEWFINDER, HANDGRIPS etc.*

*[T3] is used for different tasks which should, however,
best be left to the experts of the rental house.*

*With [T4], you exchange the GROUND GLASS and
set the mirror shutter angle.*

Caution: Compressed air should only be used for blowing the magazines! Apart from this, high pressure does more harm than good, especially to glass surfaces.

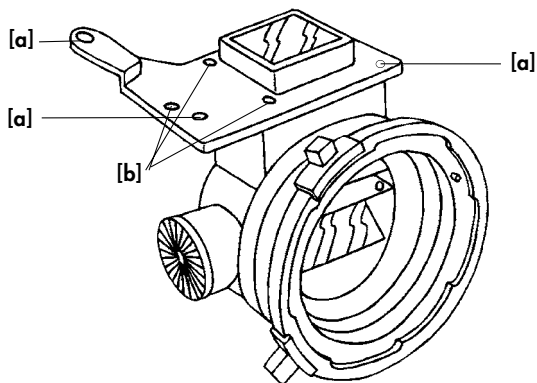

Fig. 184 – THE DIRECTORS FINDER

The DIRECTORS FINDER allows to look for setups by using the lenses of the MOVIECAM COMPACT. GROUND GLASSES (same format!), VIEWFINDER SYSTEMS, LENSES and RIGHT HANDGRIP may be attached to the DIRECTORS FINDER in the same way as to the COMPACT.

The threaded sockets **[a]** and the gauged boreholes **[b]** serve as attachment for a VIEWFINDER.

The threaded socket (M5) at the rear of the finder and the gauged hole can be used as DIRECTORS FINDER attachment.

Now that you have read the whole manual, you already know the COMPACT by heart. Just attach the tape measure to the hook and start shooting.

Good luck!

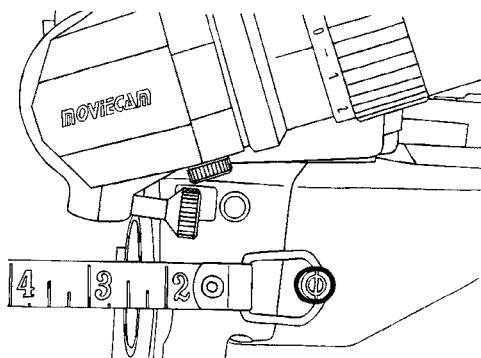

Notes:

APPENDIX

CONNECTORS AND CABLES

SYNCO BOX

SYNC IN (female)

Top View

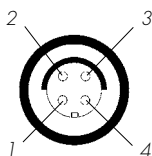

- 1 SYNC IN
- 2 MAINS IN 5V AC MAX
- 3 MAINS IN 5V AC MAX
- 4 GND (Ground, Return for Pilot)

Socket type: FISCHER D 103 A 053

VIDEO CAMERAS

VIDEO ASSIST OUT (female)

Top View

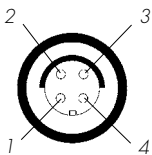

- 1 GND (ground)
- 2 +12V DC
- 3 N.C.
- 4 VIDEO SIG. OUT

Socket type: FISCHER D 102 A 053

MOVIECAM PILOT CABLE

FOR NAGRA IV PLUG (Bottom view)

MOVIECAM

SYNC OUT

NAGRA

SYNC INPUT

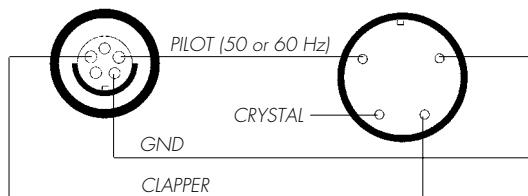

Plug type: FISCHER S 103 A 054
male

BINDER 680-1-9-0309-00-04
male

CONNECTORS AND CABLES

CAMERA FRONT

24 V SUPPLY OUTLET (female)

Top View

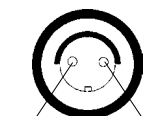

+24 V
GND
(2 Amps. max.)

Socket type: FISCHER D 103 A 051

CAMERA CONTROL PANEL

SYNC OUT (female)

Top View

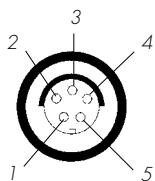

- 1 SELECT PILOT
NC-50 Hz
GND-60Hz
- 2 CLAPPER for NAGRA
- 3 TRP/ 1,7 m SEC
- 4 PILOT (5V AC, PEAK-PEAK)
selectable
50Hz at 25 FPS, 24 FPS
60 Hz at 24 FPS
- 5 GND (Ground, Return for Pilot)

Socket type: FISCHER D 103 A 054

MOVIECAM DC SUPPLY CABLE

BATTERY

CAMERA

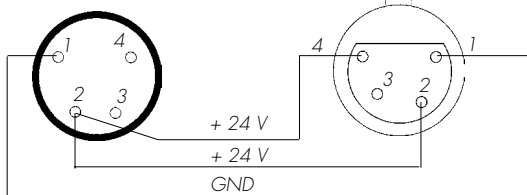

4 PINS XLR (male)

4 PINS XLR (female)