

THE PANAFLEX MILLENNIUM

Operations Manual

MILLENNIUM

6219 De Soto Avenue

PANAVISION

Woodland Hills, CA

818.316.1000 91367



text

Nolan Murdock
Gary Woods

design and production

Roger Jennings
Richard J. Piedra
Susan J. Stone

photos

Christina Peters



Copyright 2000, Panavision, Inc.

Second edition: 09/00



THE PANAFLEX MILLENNIUM

Operations Manual



Table of Contents

SECTION ONE	GENERAL SPECIFICATIONS
1.1	Cable Specifications
1.2	Camera Specifications
1.3	Camera Illustrations
1.4	Side Camera Views
1.5	Front and Rear Camera Views
1.6	Ground Glass Options
SECTION TWO	PACKING AND SHIPPING
2.1	Packing and Transport
2.2	Accessory Cases
SECTION THREE	ASSEMBLY
3.1	Camera Assembly
3.2	Digital Display
3.3	Iris Rod Bracket
3.4	On-Board Monitor and Bracket
3.5	Panalens Lite with Video
3.6	Witness Camera Monitor and Bracket
3.7	Auxiliary Carrying Handle
3.8	Follow Focus
3.9	Eyepiece Option
3.10	Eyepiece Leveler
SECTION FOUR	MAGAZINE
4.1	Magazine Loading
4.2	Inching
4.3	Checking Remaining Footage
4.4	Reversing
4.5	Brakes

Table of Contents

SECTION FIVE	CAMERA OPERATION
5.1	Attaching the Magazine
5.2	Threading the Camera
5.3	Internal Manual and Electronic Inching
5.4	Pitch and Stroke Adjust
5.5	Removing the Aperture Plate
5.6	Removing/Replacing/Lubricating Movement
5.7	Behind-the-Lens Filter
5.8	Environmental Concerns
SECTION SIX	VIEWFINDER
6.1	Focus Tube
6.2	Hand Held Eyepiece
6.3	Extension Eyepiece
SECTION SEVEN	CAMERA CONTROL
7.1	Connector Panel
7.2	Rear Panel and Controls
7.3	Operator Side Panel and Controls
7.4	Digital Display
7.5	Local Area Control (LAC)
SECTION EIGHT	VIDEO ASSIST
8.1	Video Assist Controls
8.2	Character Generator Controls
8.3	Video Output
8.4	Display Options

This manual is specific to the operation of the Panaflex Millennium. For general information and specifics on other Panaflex cameras, please refer to The Panaflex Users Manual by David Samuelson.

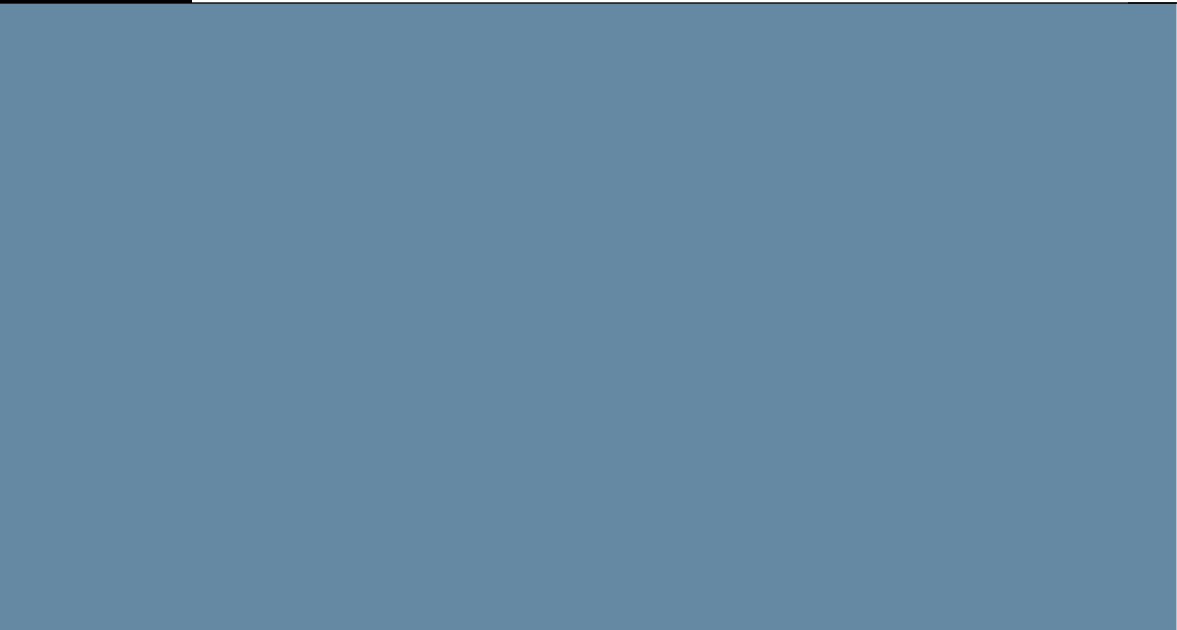

one

general specifications



1.1 Cable specifications

Focus & T-Stop Motor 7 Pin Lemo #1B to 7 Pin Lemo #1B

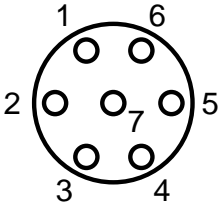

- 1 Motor +
- 2 Motor -
- 3 Ch A
- 4 +5 VCC
- 5 Ground
- 6 Ch B
- 7 ID

Auxiliary

10 Pin Lemo #2S to 10 Pin Lemo #2S

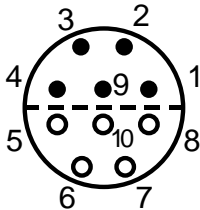

- 1 24V OUT
- 2 Camera ID
- 3 9V OUT - When camera is on
- 4 Tach OUT
- 5 Spare
- 6 Remote Clock Relay
- 7 Remote Clock Signal IN
- 8 Ground
- 9 Shutter Pulse
- 10 Remote ON/OFF

Zoom Motor

4 Pin Lemo #1B to 6 Pin Lemo #2S



- 1 Feedback 3
- 2 Feedback 4
- 3 Motor 2
- 4 Motor 5

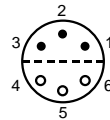

Zoom Power

2 Pin Lemo #1S to 2 Pin Lemo #1S



- 1 24V OUT
- 2 Ground



Power Cable

3 Pin Lemo to 3 Pin male XLR



- 1 24VDC
- 2 Ground



● = pin, ○ = socket

Connector as viewed from the rear with keyway up. Connectors are numbered counterclockwise in the plug and clockwise in the receptacle.

1.2 Camera specifications

Flange Focal distance	2.2488"	57.119mm
Power	24 volt System	
Speed Range	3-50 FPS forward/reverse	
Shutter Angle	11.2-180°	Electronically Controlled
Motor	DC Brushless	
Motor Control	Digital PLL	
Fuses	Auto-Reset Thermal	
Mirror	150° Full Reflex	

Camera weights and measures

Body–Steadicam Ready	PFX-M	17.2 lbs.	7.80 kg.
Focus Tube	MFT	3.9 lbs.	1.77 kg.
Extension Eyepiece	MEPX	4.7 lbs.	2.13kg.
Hand Held Eyepiece	MEPP	1.1 lbs.	0.50 kg.
1000' Magazine	MM10	12 lbs.	5.44 kg.
400' Magazine	MM4	6 lbs.	2.72 kg.
Iris Rod Bracket	MIRB	1.1 lbs.	0.50 kg.
Butterfly Digital Display	MDD	0.5 lbs.	0.23 kg.
Hand Held Rig	HHGA	4.1 lbs.	1.86 kg.
Steadicam Adapter Plate	MSCD	0.7 lbs.	0.317 kg.
Steadicam Low-Mode Adapter	MSCPA	0.5 lbs.	0.23 kg.

1.3 Camera illustrations-400' magazine

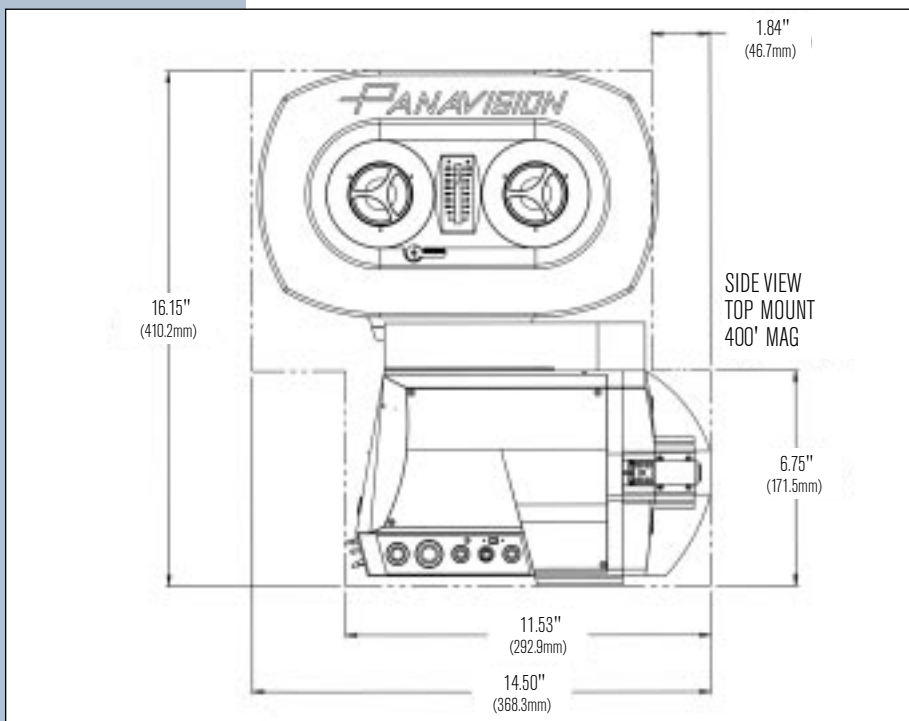
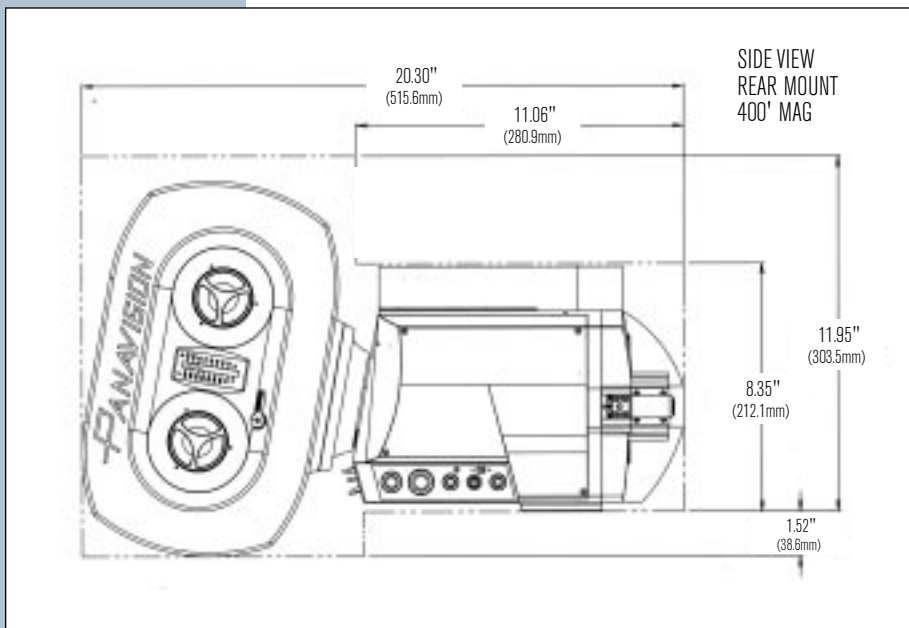

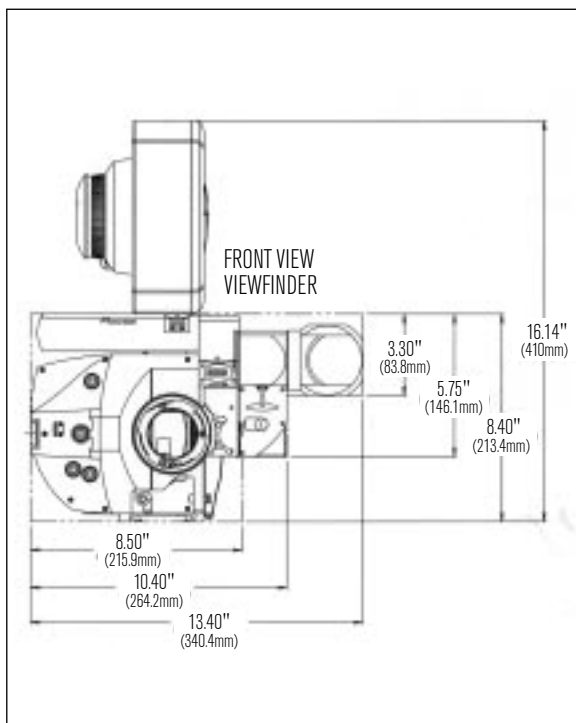
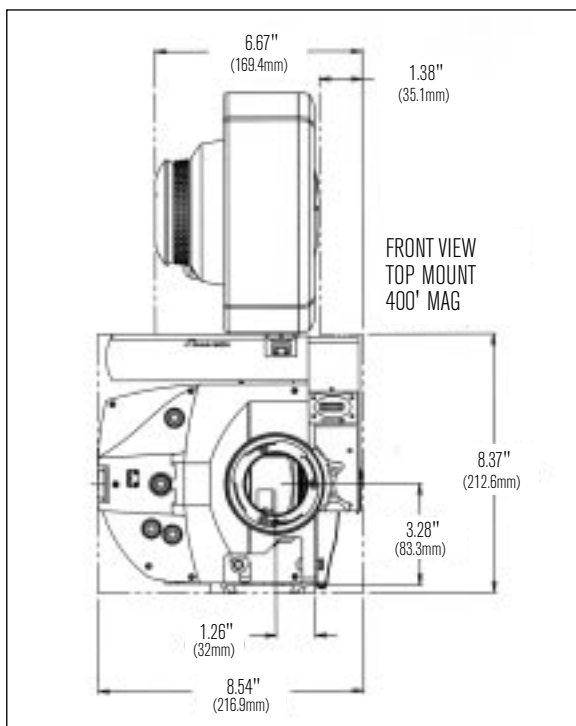

1.3 Camera illustrations–1000' magazine

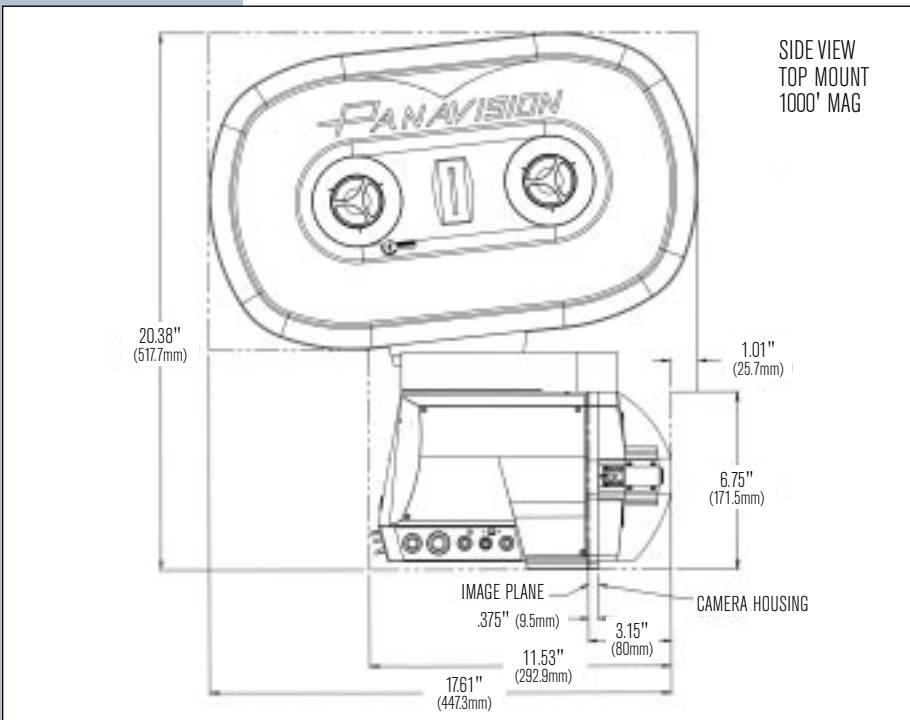
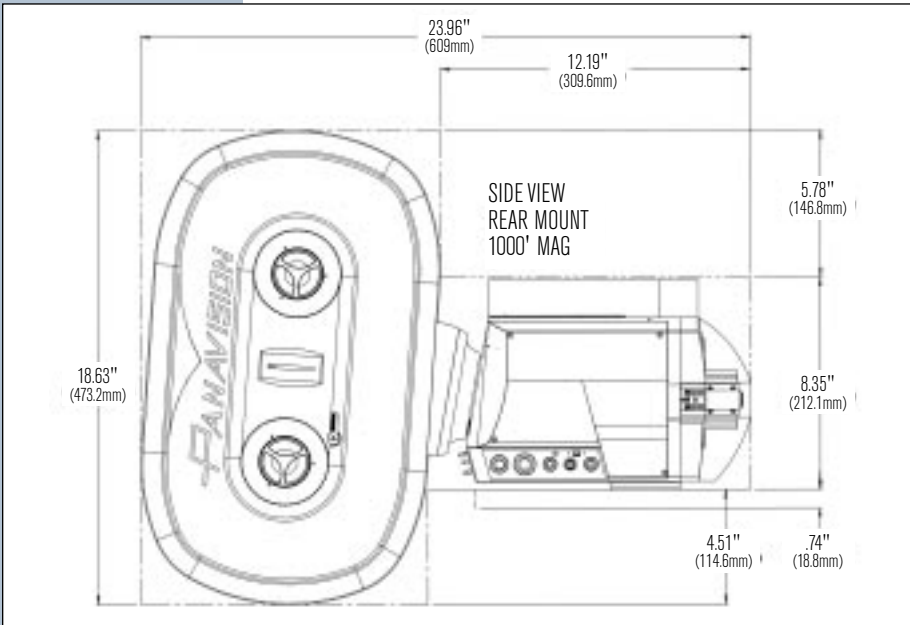

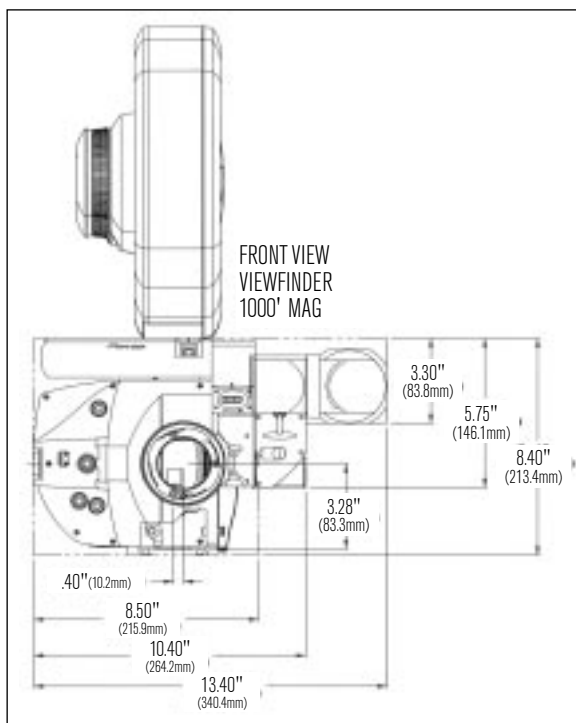
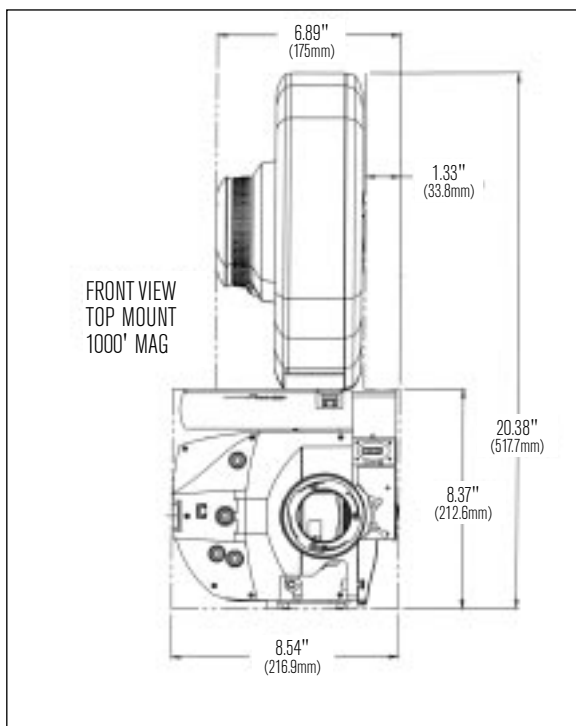

1.4 Side camera views

FOOTAGE
INDICATOR

INCHING
KNOBS

FOOTAGE
LEVER

VIDEO
ASSIST

REMOTE
HOT SHOE

CONNECTOR
PANEL

TAPE
HOOK

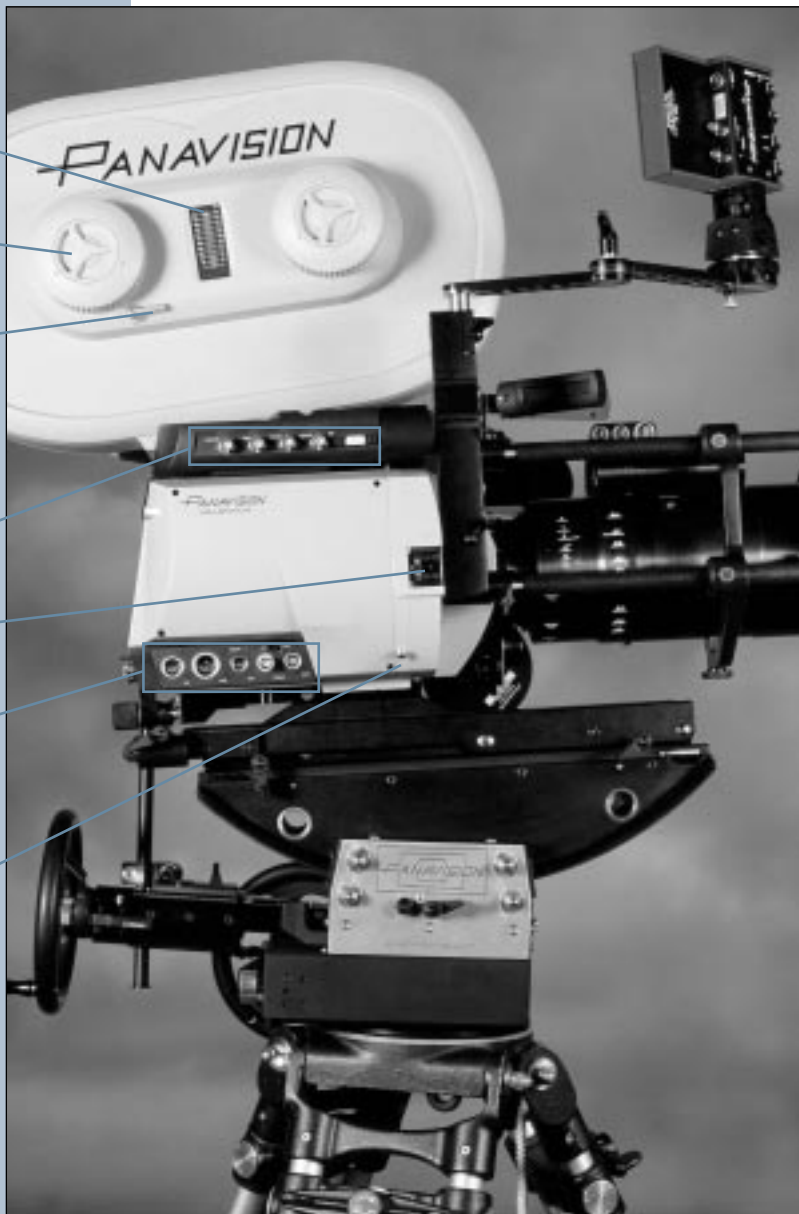



1000'
MAGAZINE

5" LCD
MONITOR
WITH BRACKET

BUTTERFLY
DIGITAL
DISPLAY

EXTENSION
EYEPIECE

PANAGLOW

FILM DOOR

FOLLOW
FOCUS

DOOR SIDE
DIGITAL
DISPLAY

CAMERA
ON/OFF

EYEPIECE
LEVELER

1.5 Front and rear camera views

IRIS ROD
BRACKET

MONITOR
BRACKET
LOCK

BUTTERFLY
DIGITAL
DISPLAY

12V DC,
24V DC OUT

VIDEO IRIS

FOCUS, T-STOP
ZOOM MOTOR
CONNECTORS

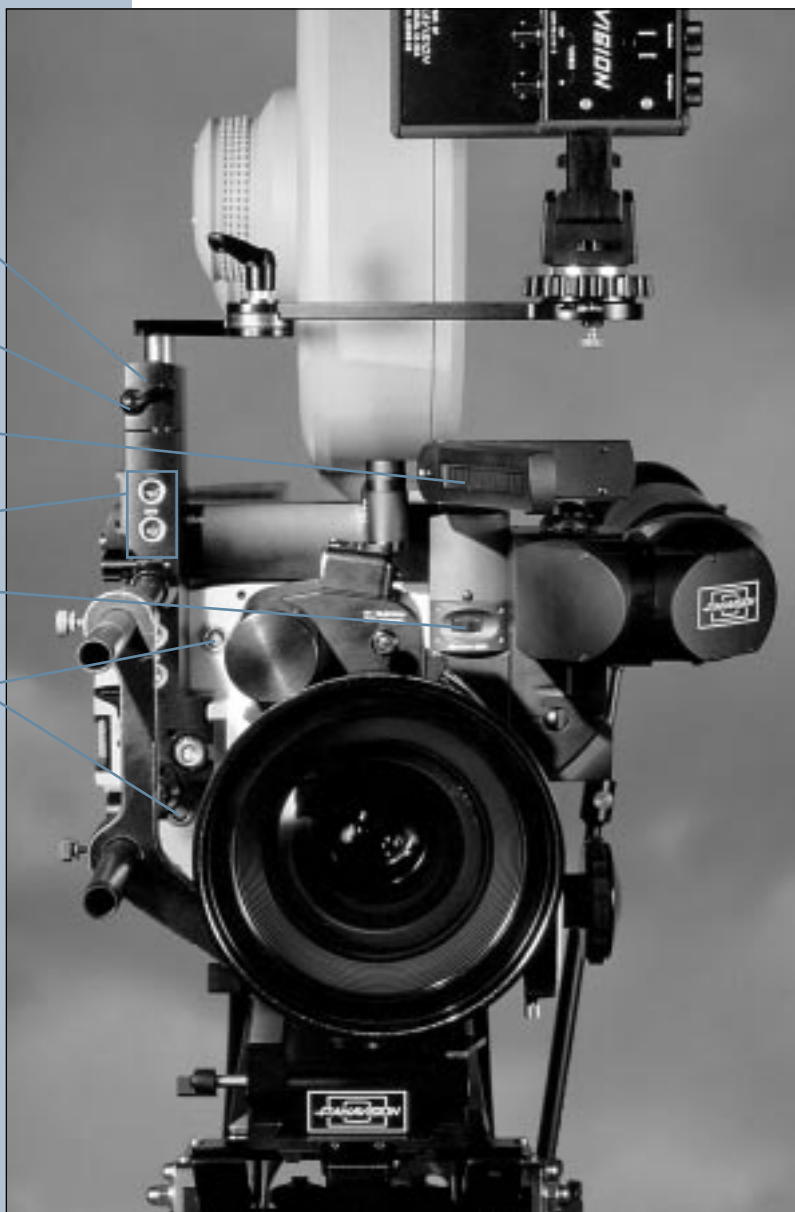

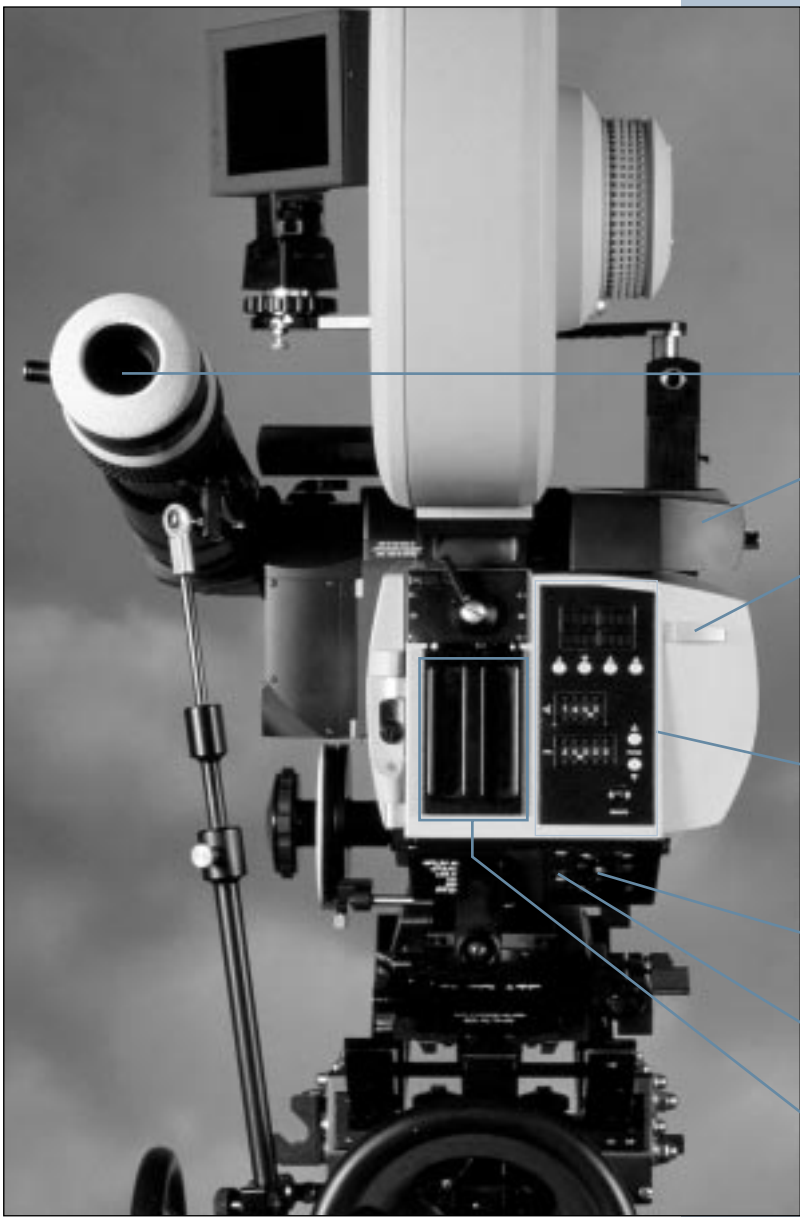

PANACLEAR

VIDEO ASSIST

EYEGASS HOLDER

REAR PANEL & DIGITAL DISPLAY

CAMERA ON/OFF

FORWARD REVERSE SWITCH

REAR MAGAZINE PORT

35MM THEATRICAL FORMAT

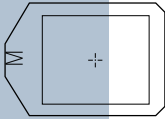

2x Anamorphic
2.40:1

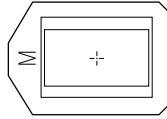

1.85:1 – Academy

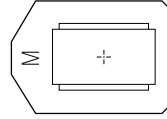

1.85:1 – TV

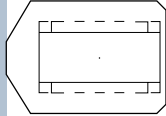

Super Panavision 35 – Symmetrical
2.40:1 – 1.85:1 – 1.33:1 (4x3)

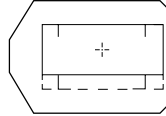

Super Panavision 35 – Common Head Room
2.40:1 – 1.85:1 – 1.33:1 (4x3)

35MM TELEVISION FORMAT

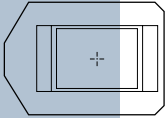

Super Panavision 35
Television 4 Perf
1.78:1 (16x9)
1.33:1 (4x3) TV Trans & Safe

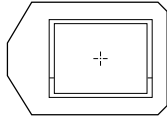

Super Panavision 35
1.33 TV Safe
1.78 & 1.33 TV Trans with Common Top

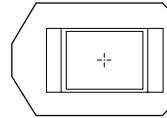

Super Panavision 35
Television 3 Perf
1.78:1 (16x9)
1.33:1 (4x3) TV Trans & Safe

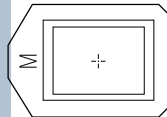

4 Perf
1.33:1 (4x3) Safe – Academy

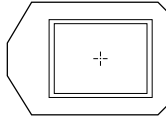

Super Panavision 35
4 Perf
TV Trans & Safe/Large TV

1.6 Ground glass options

The Millennium can be outfitted with the ground glass in two different locations depending on production demands. Under most conditions, the camera is shipped with the ground glass located in the traditional first image plane location. However, for situations requiring very high-resolution video assist images, the traditional ground glass can be replaced by a clear format screen and a focus screen placed in a second image plane. Foreseeable applications include intensive on-set compositing or non-linear editing.

Millennium ground glasses are indicated with an “M” next to the description. When shooting in Super 35 the Millennium utilizes existing Panaflex Super 35 ground glasses.

CAUTION: *Do not use standard PFX Academy ground glass. Millennium viewing mattes must be used.*



two

packing and shipping



**FOLLOW FOCUS
KNOB
& GEARBOX
MFFSK, MFFGB**

**CAMERA BODY
PFX-M**

**CAMERA
BASEPLATE
PCOB**

**HAND HELD
EYEPIECE
MEEP**

**IRIS ROD
BRACKET
MIRB**

**EXTENSION
EYEPIECE
MEPX**

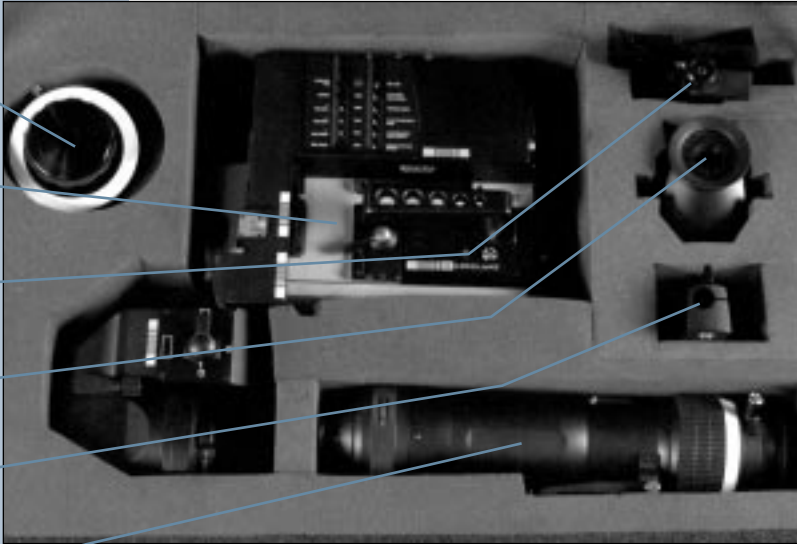

2.1 Packing and transport

The camera system is comprised of four cases; one containing the camera body and viewfinding components, the others containing camera accessories. The camera is delivered without either eyepiece attached to the viewing system and it is recommended that it ships this way. It is also advisable to remove the digital display before shipment.

CAMERA ACCESSORIES

LENS LIGHT,
HANDLE,
FILTER HOLDERS
PLLV, PCLAHP

MATTE BOX
& RING

MB

MODULAR
FOLLOW FOCUS
EXTENSION

MFFEX

POWER, MOTOR
& MISC.
CABLES

DUAL
SPEED KNOB

MFF2SK

REMOTE
CONTROL
LAC

DIGITAL
DISPLAY

MDD

SPEED
CRANK
FXHL

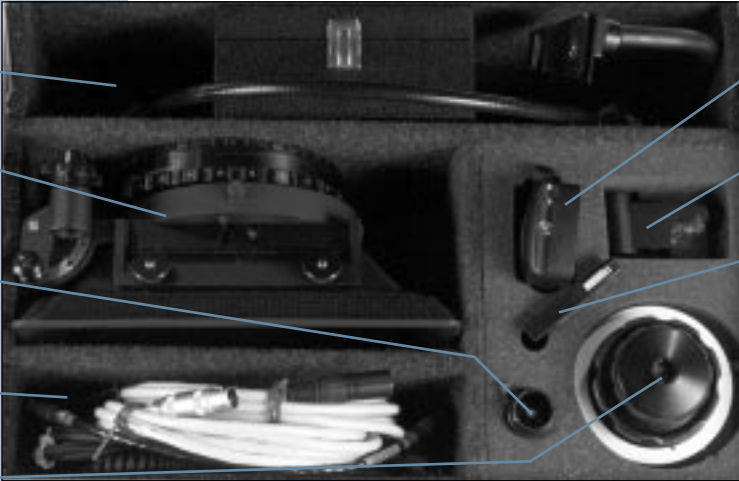

HAND HELD ACCESSORIES

HAND HELD
ACCESSORIES
AND SUNSHADE

HHGA

EYEPIECE
LEVELER OR
EXTENSION EYEPIECE

EPL-M

HAND HELD
EYEPIECE

MEEP

MISC.

FOCUS TUBE
(FOR STEADICAM MODE)

MFT



VIDEO ACCESSORIES

MONITOR
BRACKET

MMB

WITNESS
MONITOR
BRACKET

MWMB

5" ON-BOARD
MONITOR

LCDM5

WITNESS
MONITOR

MWM

VIDEO
& POWER
CABLES

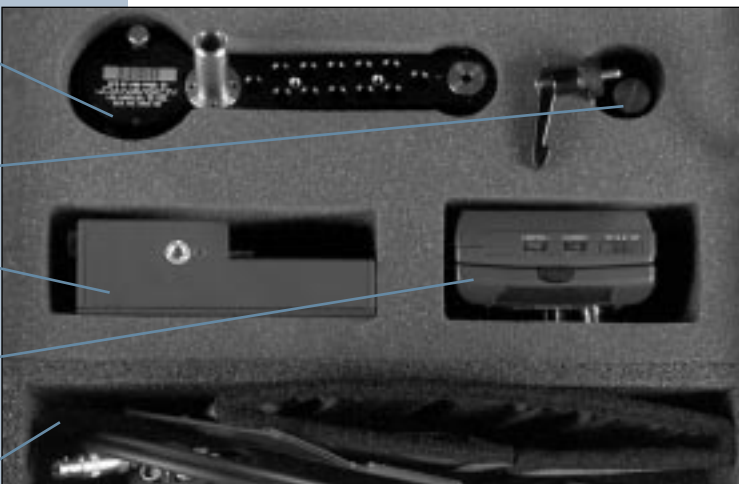

2.2 Accessory cases

The accessory cases contain all brackets, monitors, cables, etc., required to fully integrate a Millennium camera.

In addition to the nominal complement of accessories there may be other items in the cases, such as:

- Hard mattes
- Camera mounts

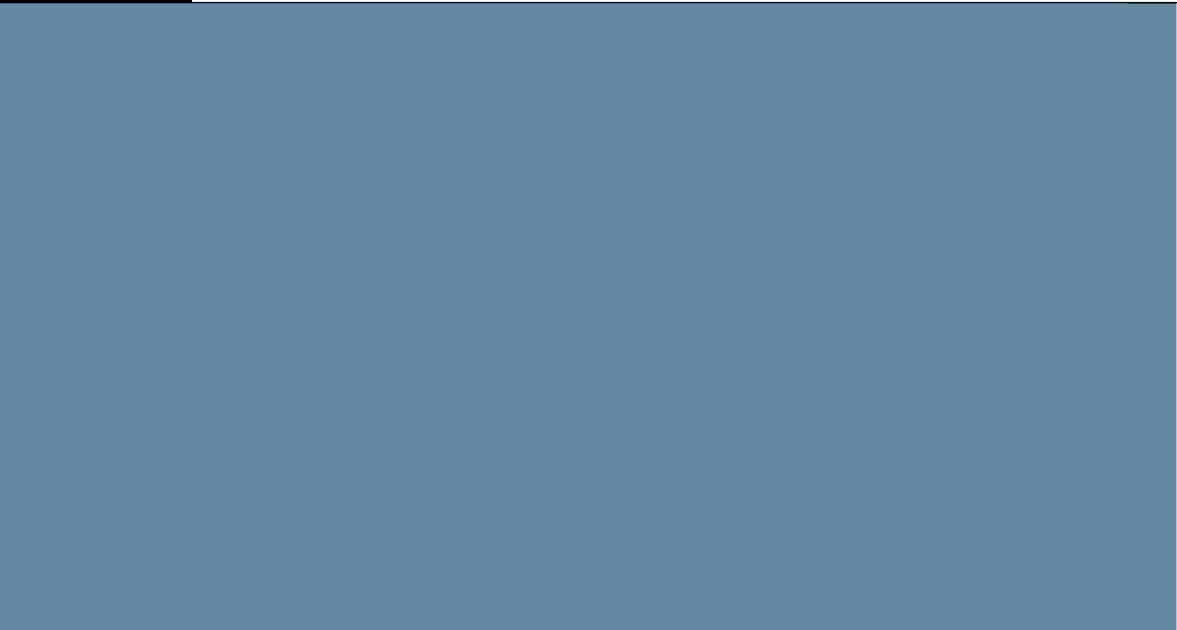

three

assembly



DIGITAL
DISPLAY
DOVETAIL

ZOOM
MOTOR
CONNECTOR

POWER
POGOS

PANALENS LITE,
RIGHT HAND GRIP
OR REMOTE
ON/OFF DOVETAIL

24V DC

IRIS ROD
BRACKET
MOUNT

FOCUS
MOTOR
CONNECTOR

T-STOP MOTOR
CONNECTOR



3.1 Camera assembly

This section describes the attachment of each camera accessory and its use, beginning at the camera faceplate (pictured left), and continuing counter clockwise around the camera body.

DIGITAL
DISPLAY

DOVETAIL
(UNDERNEATH)

VIDEO
HOUSING



3.2 Digital display

To install, align dovetail on the display with the dovetail on top of the video housing and push on until the Panaclick is heard. To remove, depress the button on the digital display and pull toward you.

**MONITOR
BRACKET
LOCK**

**12V DC
24V DC**

FUTURE

**BRACKET
LOCK LEVER**

**CAMERA
MOUNT**

**IRIS ROD
LOCK**



3.3 Iris rod bracket

Push bracket onto camera mount and tighten bracket lock lever. The iris rod bracket is automatically powered from the camera contacts.

**MONITOR
CONTROLS**

POWER INPUT

VIDEO IN/OUT

INVERT SWITCH

SWIVEL BASE

**SWIVEL BASE
SAFETY LOCK
(PULL DOWN)**

**BRACKET
LOCK**

**IRIS ROD
BRACKET**

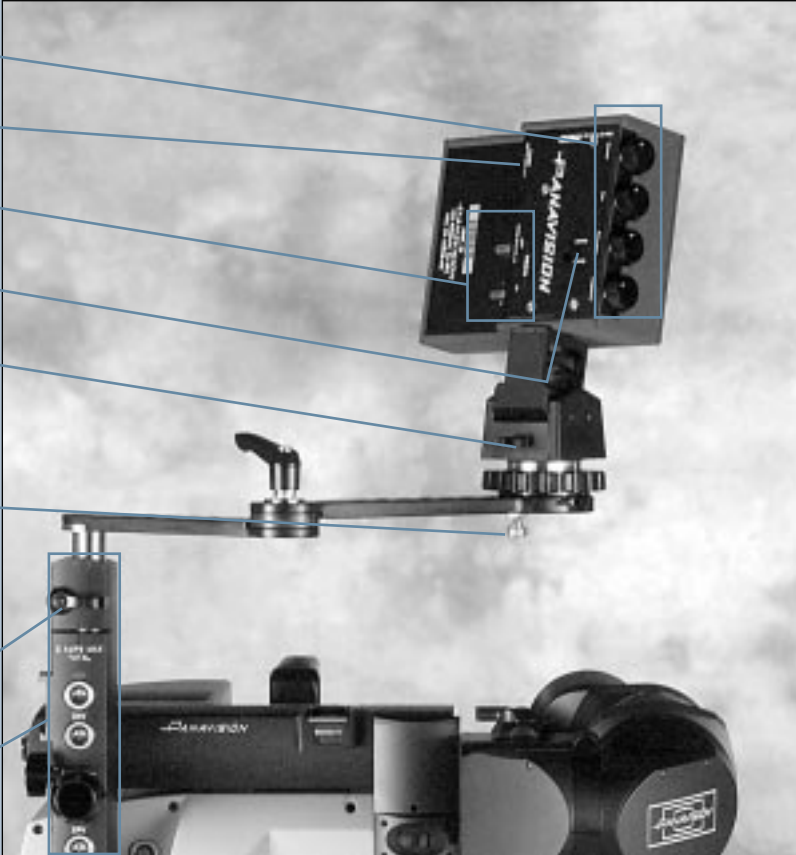

3.4 On board monitor and bracket

Mount the monitor to the swivel base by screwing the thumbscrew into one of the threaded inserts located on the top or bottom of the monitor. Insert the stud of the bracket into the receiver at the top of the iris rod bracket and tighten the lock lever.

Brightness, color, tint, and contrast controls are located on the side of the monitor while power and video in/out are located on the back. If the image is upside down, slide the invert switch up or down. This switch is located on the back next to the video controls.

A sunshade may be attached to the velcro strips around the front edge of the monitor for outdoor use.

Monitor operates on 12V to 24V DC power.

DOVETAIL

24 DC IN/OUT

DIMMER CONTROL

VIDEO OUT

LOCK

DOVETAIL FOR FACEPLATE

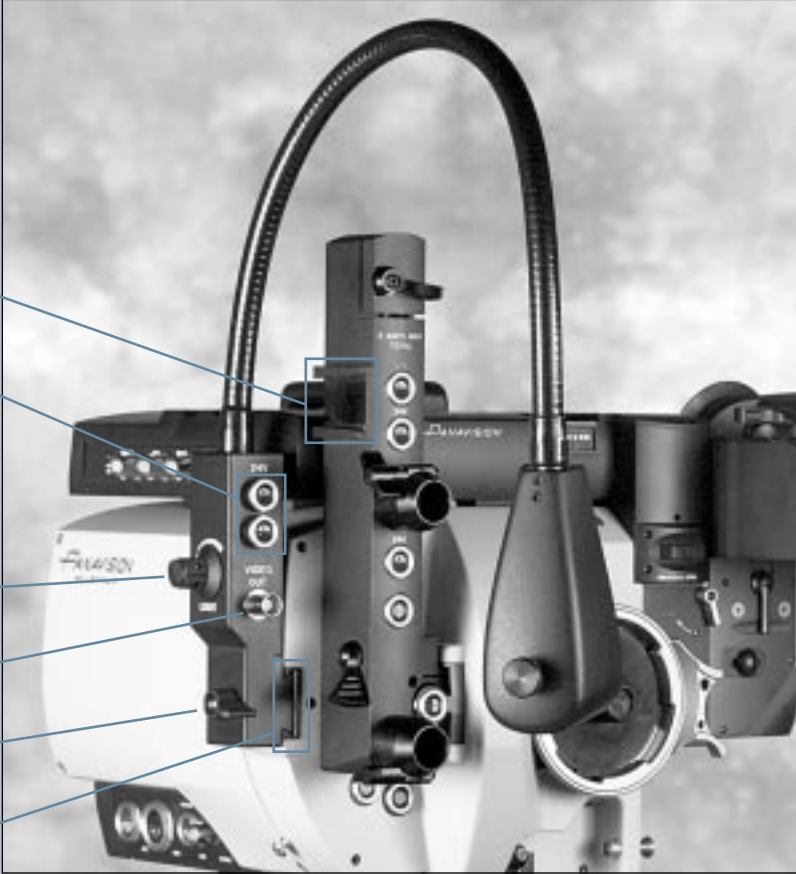
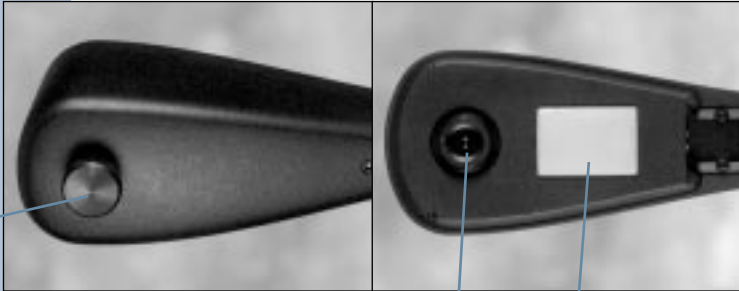

IMAGE ORIENTATION



FOCUS RING

LAMP

3.5 Panalens Lite with video

The Panalens Lite incorporates a small B/W video camera that can be used as a lens witness camera when the Millennium is mounted on a crane or when remote focus is desired. The lens light mounts to a dovetail located on the motor cover side of the faceplate, or it can be mounted to a dovetail on the iris rod bracket. A short power cable is plugged into the 24V DC outlet on the iris rod bracket or faceplate and into the lens light. The Panalens Lite incorporates a dimmer control located on the main body of the light.

The video camera can be placed in the desired position by turning the gooseneck. Image orientation can be adjusted by rotating the control on the back of light. Focus is accomplished by turning the lens barrel on the front of the light.

ON-BOARD
MONITOR

MONITOR
CONTROLS

WITNESS
CAMERA
MONITOR

VIDEO/24V
POWER IN

BRACKET



3.6 Witness camera monitor and bracket

The witness camera monitor can be mounted to the on board monitor bracket by attaching the threaded knob to any of the tapped holes. This monitor will typically be used in a remote location as the camera is likely to be on a crane. 24V power and video input is provided through connectors on the rear.

A power on/off switch, along with video controls are located on the top of the monitor.

FILM PLANE
TAPE HOOK



3.7 **Auxiliary carrying handle** (Hollywood Handle)

The auxiliary carrying handle mounts to the rear magazine port and screws into the tapped insert on the rear of the iris rod bracket.

The handle incorporates a film plane tape hook to facilitate distance measurements.

ADAPTER PLATE—FIRST POSITION

STUD
ADAPTER
PLATE
LOCK
PLUNGER

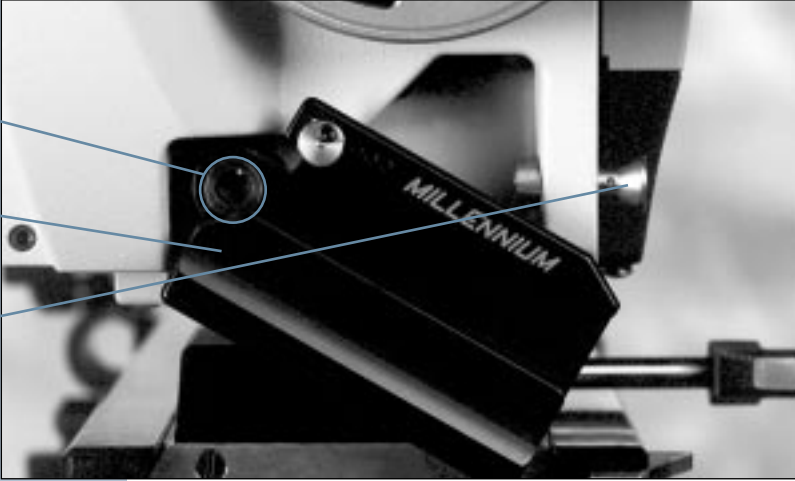

ADAPTER PLATE—ENGAGED



GEARBOX AND KNOB—ATTACHED

SINGLE
SPEED KNOB
GEAR BOX
LOCK
LEVER

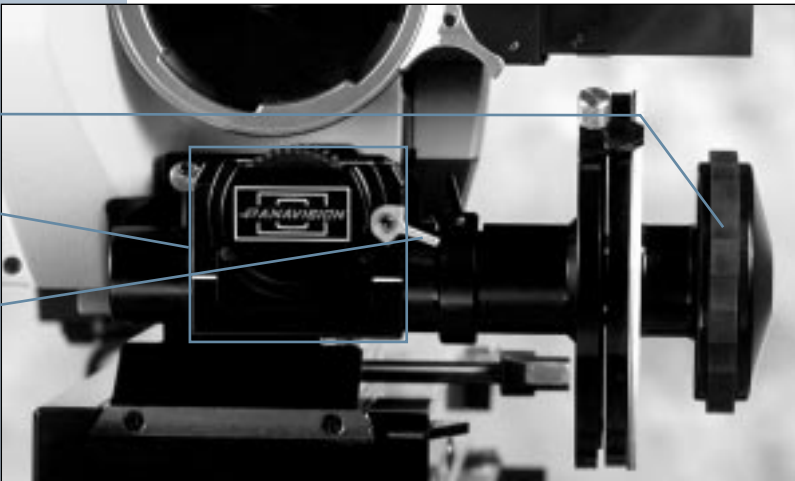

3.8 Follow focus

The Millennium comes standard with a modular follow focus unit consisting of:

- Follow focus adapter plate
- Modular follow focus gear box
- Single speed knob
- Dual speed knob
- Extension
- Whip
- Speed crank

Please note that all follow focus devices including modular follow focus adapters, standard follow focus and remote follow focus motors must be configured for Panastar use.

The follow focus adapter plate mounts to the camera just below the lens port. Push the adapter onto the stud located below and to the left (viewed from front) of the lens port, then pivot the right edge up into the lock plunger.

To remove, pull out lock plunger, pivot adapter downward and pull off of the stud. The adapter may be left in place during transport.

The gear box and single speed knob are shipped as a unit. The gear box slides into the dovetail on the adapter plate and locks from the front. If a dual speed knob or extension are required, remove the single speed knob by rotating the lock lever on the knob and pulling from the gear box. Install the dual speed knob or extension by pushing it onto the gear box and locking it. To ensure proper operation, be sure the key in the end of the knob or extension is properly engaged into the slot in the gear box.

**EXTENSION
LOCK**

**EYEPIECE
LOCK**

**PIVOT
LOCK**

KNUCKLE



3.9 Eyepiece option

The Millennium ships with a short hand held eyepiece and an extension eyepiece. Both eyepieces mount in the same fashion.

The camera ships with a protective cover mounted in the eyepiece lock. To remove the cover, depress the button on the lock ring and rotate counter to the lock arrow. Remove the cover and place the eyepiece in the lock ring, making sure the slot in the eyepiece flange is mated with the key in the lock ring. Rotate the lock in the direction of the arrow.

If you are mounting the extension eyepiece, you may find it easier to rotate the knuckle into the straight up (sky) position and then insert the eyepiece into the lock ring. The knuckle pivot lock is a knurled knob located just to the front of the eyepiece lock ring.

See section 6.1 on the viewfinder for further information on the eyepieces.



EYEPIECE
ATTACHMENT

HEIGHT
ADJUSTMENT

SCREW TO
PANAHEAD

TILT
GEARBOX

3.10 Eyepiece leveler

The eyepiece leveler is used to keep the eyepiece level as the camera is tilted up and down.

The bottom of the leveler screws into a tapped hole in the tilt gearbox on the Panahead. The top incorporates an eyepiece attachment. Squeeze the two lock tabs together and push onto the stud located on the rear of the extension eyepiece. Height adjustments are made by loosening the lock screws and pushing or pulling the telescoping sections in and out. To remove, squeeze the lock tabs together and pull from the stud.

CAUTION: The eyepiece knuckle *must* be unlocked in order to avoid damage during operation.

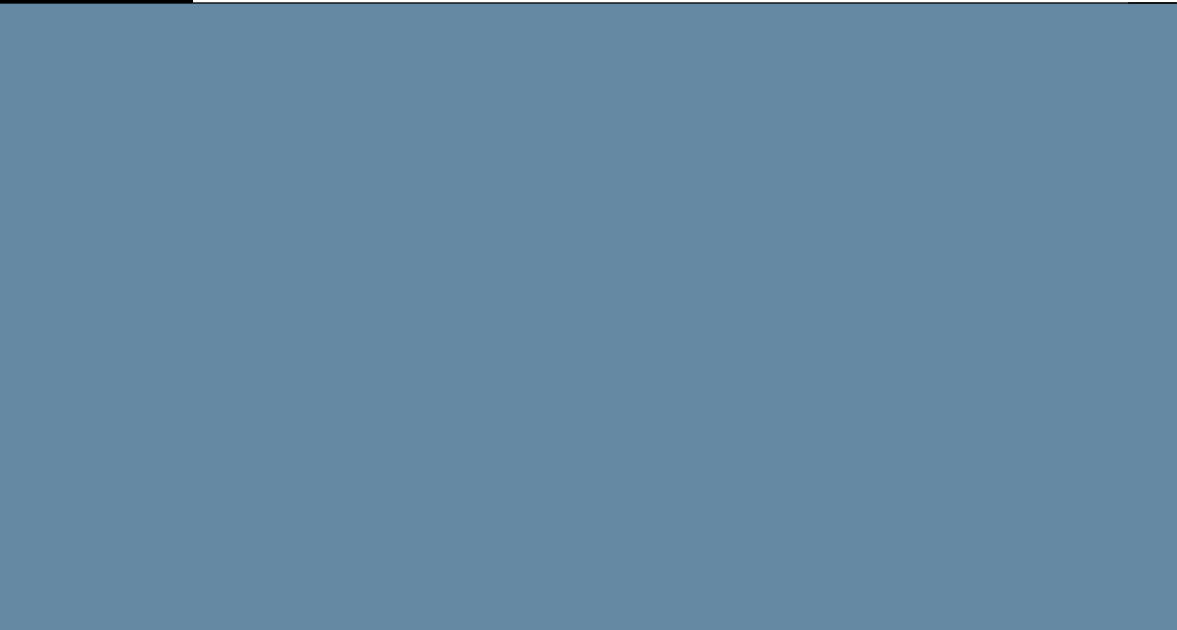

four

magazine

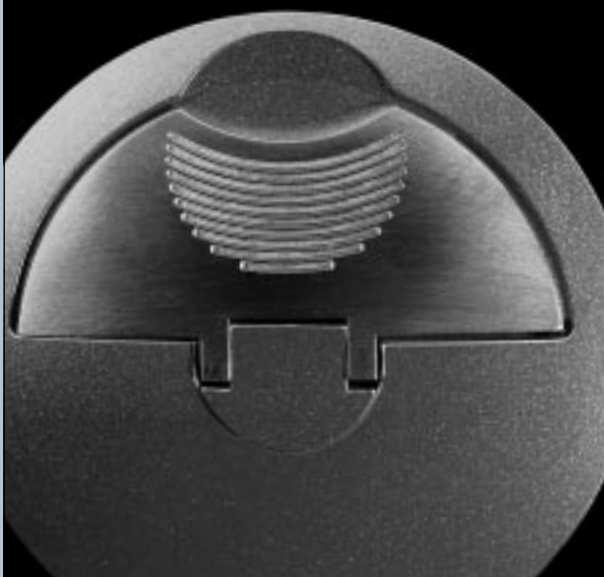

COVER
LOCKS

MAG TRAP



FOOTAGE
COUNTER
MECHANISM

FEED

TAKE UP



4.1 Magazine loading

The Millennium magazine incorporates a dual motor system. The magazine controls the speed of the feed motor and of the take up motor for quiet operation and proper take up tension.

Lift the cover locks out of their recesses and turn both counter-clockwise to release, and remove the cover.

Pull back the top lock of the feed side spindle and transfer the plastic film core from the feed side of the magazine. Place it on the take-up spindle with film slot facing counter-clockwise. If there is not a spare core in the magazine, one must be provided.

The film is loaded in a “99” configuration. The Millennium utilizes a single large roller in the light trap. When loading, the tail from the feed side should be pushed into the slot to the left of the large roller. Grasp the tail of the film and insert it into the right slot of the trap. The tail should now be inside the magazine. Pull the film to the right hand side of the take up film core, locate the slot in the core and insert the end of the film into the slot. Rotate the take up core counter-clockwise several turns.

Replace the magazine cover to its proper seated position and rotate the locks clockwise to lock.

When preparing the magazine for installation on the camera, hold the film entering the take up side stationary, and pull the film from the supply side to the proper length. This prevents the film entering the take up side from pushing up and coming off of the core.

HAND GRIPS

INCHING
KNOBS

FOOTAGE
INDICATOR
LEVER

REMAINING
FOOTAGE
SCALE



4.2 Inching

The inching knobs are located on the back of the magazine in the center of the hand grips. To inch, depress and rotate the knobs.

4.3 Checking remaining footage

The remaining footage indicator is located on the back of the magazine between the two hand grips. To read remaining footage push the actuator lever down until it contacts the film, then read the scale. The actuator will return to a neutral position when released.

4.4 Reverse

For double exposure shots, the camera must be switched from forward to reverse. If a single pass reverse shot is desired, the film must be loaded on the take-up spindle. This requires the film to be rewound so that the emulsion side is out.

4.5 Brakes

Two solenoids are used to apply braking to the feed and take-up spindle. This prevents film from unspooling during transportation of a loaded magazine. The solenoids are engaged when the camera is powered down. An audible “click” may be heard when this occurs.

When Millennium magazines are used on other Panaflex cameras, the solenoids will engage and disengage each time the camera is rolled.



five

camera operation

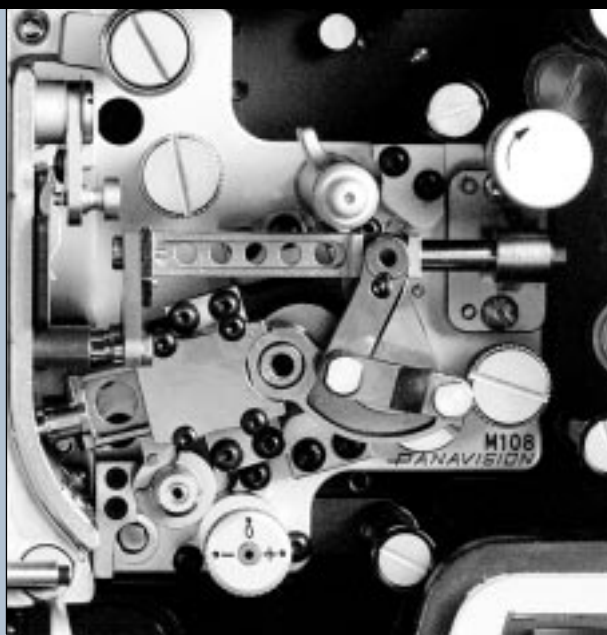

TOP MAGAZINE PORT

MAGAZINE
LOCK

SAFETY
CATCH



5.1 Attaching the magazine

The Millennium incorporates a magazine port on the top and back. The top port is generally fitted with a 1000' magazine, while the rear port is used with a 400' magazine in hand held or Steadicam configuration. Mounting for each port is the same.

The magazines mount in locking dovetails. The magazine and port each incorporate a set of contacts. The contacts are located to the front (lens) and must mate for proper operation. In the case of the rear port, the contacts are located on top. Before placing the magazine on the camera port, pull 6" to 8" of film out of the magazine into the film compartment. The lock is located just in front of the contacts. The lock is located on top if the magazine is mounted on the rear port.

Rest one end of the magazine on the camera, feed the film loop through the magazine port and lock the magazine securely in position.

LOCATING PIN

FINGER TAB
FOR INSERTING
REGISTRATION
PINS

REGISTRATION
PIN RETRACTOR

REGISTRATION
PINS

PULLDOWN
CLAWS

MANUAL
INCHING KNOB

SPROCKET
3 & 4 PERF

UPPER & LOWER
SPROCKET
KEEPER
ROLLERS

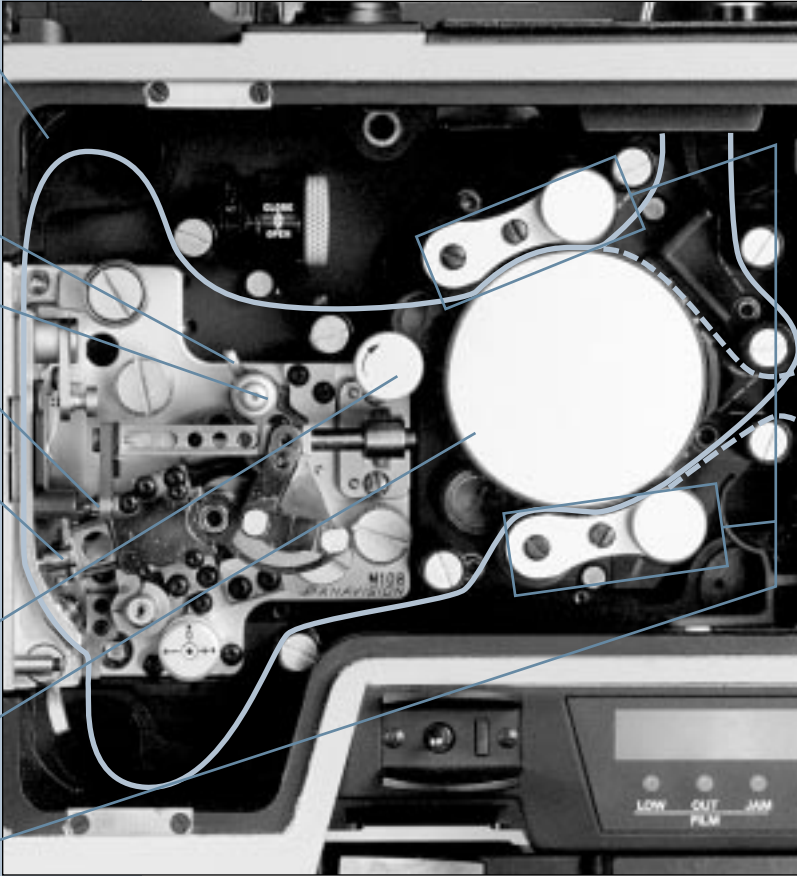

TOP LOAD

REAR LOAD

5.2 Threading the camera

Inch the camera until the pull-down claw is at the bottom of its stroke and out of the film path. Pull out the registration pins retractor and retract the pins in order to clear the gate. Pull out a very short loop from the supply side of the magazine.

NOTE: *While threading the camera, do not inch the camera until the film on the take-up side has been securely located on the sprocket, and the bottom sprocket keeper has been closed. (Turning the inching knob will activate the magazine take-up motor. Ensure that the film has been properly secured on the main sprocket.)*

THREADING THE FILM

Pull about 8" of film from the supply side of the magazine and stretch it towards the bottom left hand corner of the camera. Open the top and bottom sprocket keepers.

Thread the film through the camera exactly as shown on the threading diagram on the inside of the camera door. Double check that it is correct.

Check that the film on the take-up side is properly seated on the underside of the sprocket and close the bottom sprocket keeper.

Set the bottom loop so that it just clears the bottom of the camera.

Press a film perf onto the perforation locating pin situated just above the aperture plate. This will ensure that the perforations will be correctly aligned with the registration pins. At the same time, gently press on the edge of the film to ensure the film is fully back into the movement.

Set the registration pins into the perforations by gently pressing the finger tab at the top of the retraction pin. If it does not go easily, recheck the perforation alignment.

Set the top loop by pulling the film off the perforation locating pin. The top loop should be set to clear the locating pin.

Engage the film on the top of the sprocket and close the top keeper. If the camera has been disconnected, re-connect the camera power supply.

LOCATING PIN

MANUAL SHUTTER OVERRIDE

TOP LOCK (SEE 5.5)

MANUAL INCHING KNOB

STROKE CONTROL (SEE 5.4)

PITCH CONTROL (SEE 5.4)

BOTTOM LOCK (SEE 5.5)

ELECTRONIC INCH & RUN

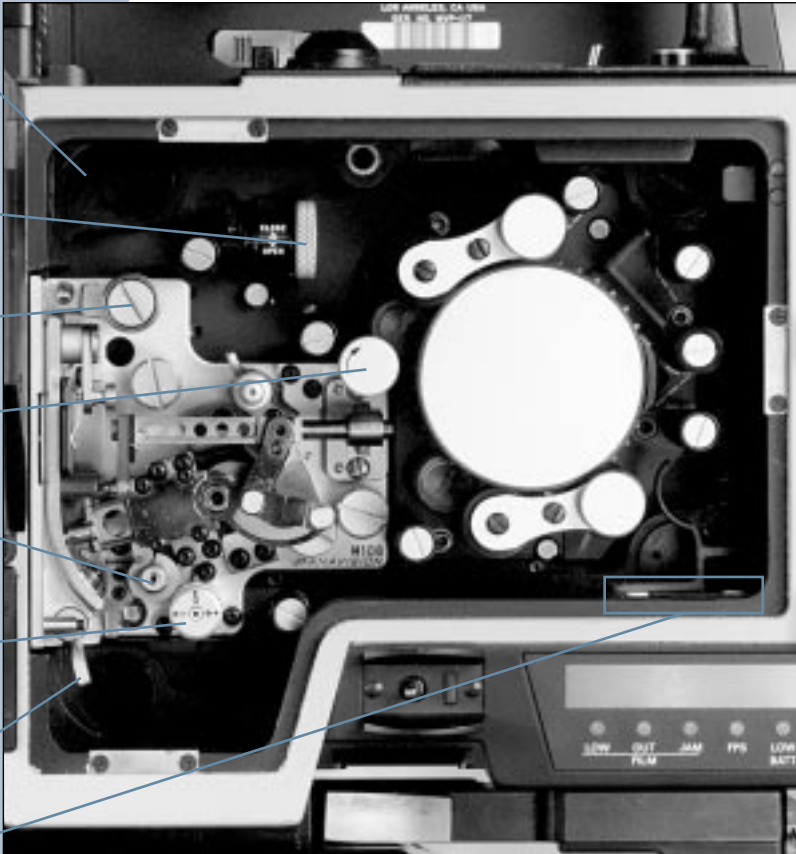

5.3 Internal manual inching

Electronic inching

Electronic run

Manual shutter override

To manually inch, rotate the manual inching knob in the direction of the arrow.

NOTE: *The magazine will take up.*

To electronically inch or run, depress either the inch or run buttons to activate.

The manual shutter override should be used only in an emergency situation. To utilize, set the shutter angle switches on the control panel on the back of the camera to zeros. Remove the film and the pressure pad. Normal shutter angle markings are engraved on the back of the shutter and can be set by rotating the manual adjustment open or close.

If the camera is running, the shutter angle will be displayed on any of the digital displays and will dynamically change as the manual override is opened or closed.

STROKE
CONTROL

PITCH
CONTROL

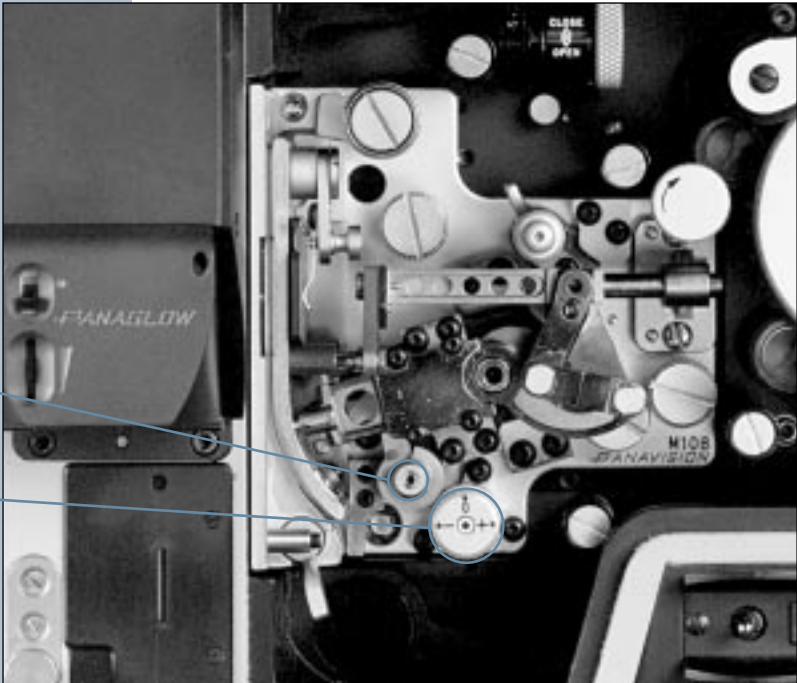

5.4 Pitch and stroke adjustment

To ensure quiet running, adjust the pitch adjustment by running the camera at speed and rotate the pitch control knob clockwise or counter-clockwise until the perforation noise is minimized. This adjustment should be made at every reload.

The stroke adjustment is made utilizing a special tool and is generally preset at time of rental. This adjustment is made in order to optimize the amount of film which is pulled down each time ensuring clean entry of registration pins. The stroke adjustment is made while the camera is running. However, in order to minimize the possibility of damage, it is advisable to only insert or remove the tool while the camera is off.

TOP LOCK

REGISTRATION
PIN
RETRACTOR

BOTTOM
THUMB LOCK

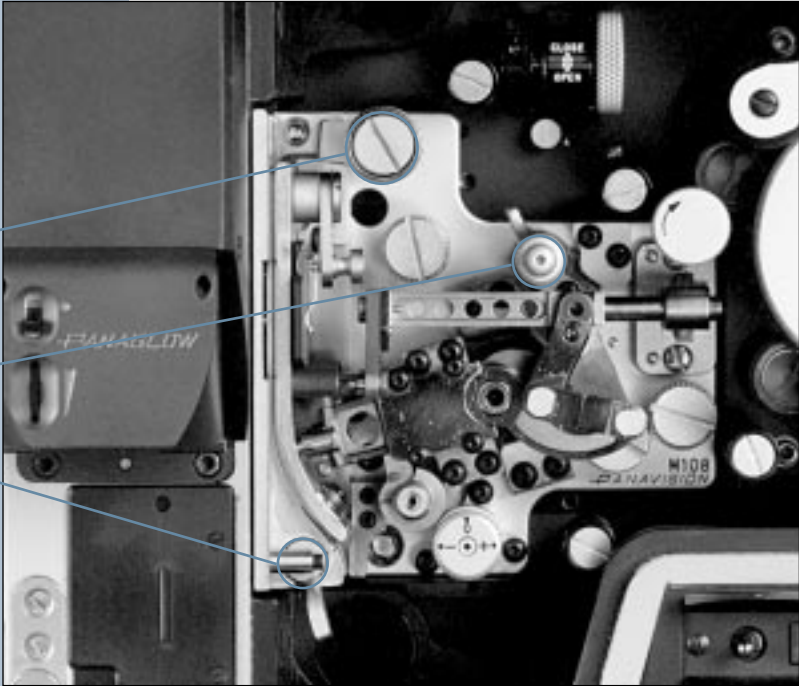

5.5 Removing the aperture plate

To remove the aperture plate, inch the camera until the pulldown claw is at the bottom of its stroke, disengaged from the film, with the registration pins fully engaged.

Pull out the spring-loaded registration pin retraction knob and pull the pins back to clear the gate.

Turn the top lock clockwise and the bottom thumb lock counter-clockwise. Hold the bottom lock horizontally and pull to remove the plate.

Replace the aperture plate by holding the bottom lock horizontally and pushing the plate onto the top locating pin. Push the bottom lock down and set top lock by pulling it out and turning it counter-clockwise.

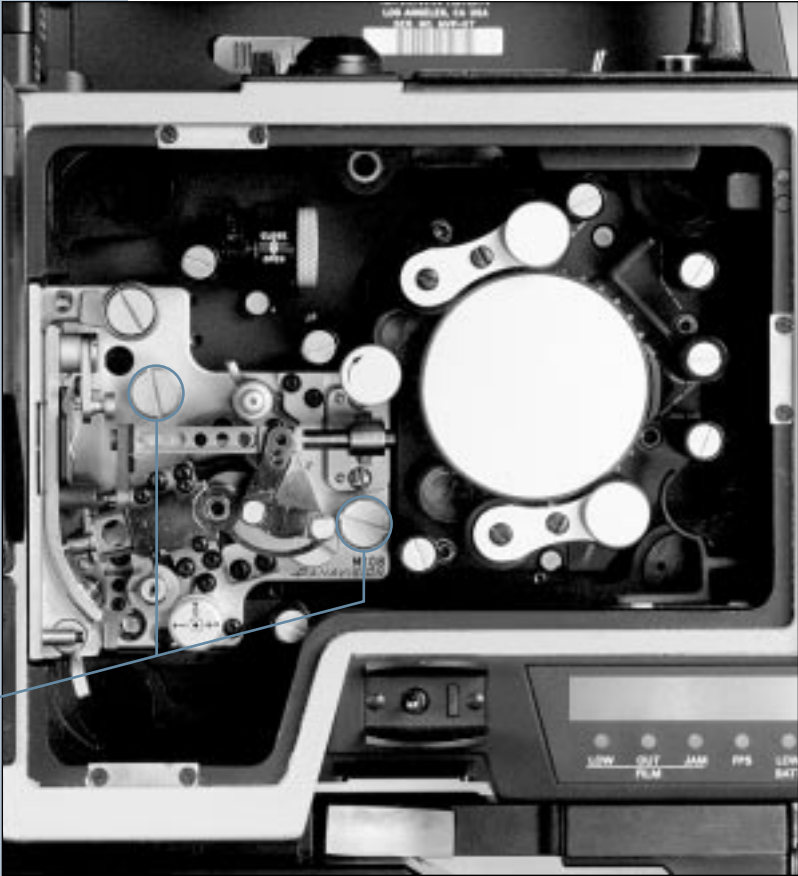

**MOVEMENT
SCREWS**

5.6 Removing, replacing, and lubricating movement

Inch the camera until the pulldown claws are at the bottom of the stroke and fully withdrawn from their slots. Stop just before the pulldown claw arm obstructs the lower movement lockdown screw.

With a wide screwdriver, gently loosen the two short movement screws which secure the movement plate. Unscrew approximately five turns until they become loose in their bushings. Remove movement by pulling on the pitch control knob, wiggling to loosen.

To replace the movement, inch the camera until the pins of the motor coupling are horizontal, and the witness mark is downwards. Similarly, align the movement shaft so that it matches the camera coupling. Hold the movement with both hands using the left hand for support and the right hand to guide the movement into position.

Hold the movement with the thumb on the pitch control knob and the forefinger on the top aperture dog-lock. Then slide the entire unit into the camera interior and engage the coupling in the camera body with the witness marks aligned. Secure the movement with the short knurled-head capture screws and tighten with a wide screwdriver. If the screws do not bottom out solidly, the movement is not seated properly.

NOTE: *The interface between the motor drive coupling and the movement coupling is offset so they cannot be assembled incorrectly. If the movement does not seat, inch the camera back and forth slightly until the couplings fit snugly together. If it still does not seat, remove and check the drive and movement couplings for possible damage.*

OIL

OIL

OIL

OIL

REGISTRATION
PIN BUSHINGS
(NOT SHOWN)

OIL

SILICONE
FELT PADS

OIL

OIL

OIL

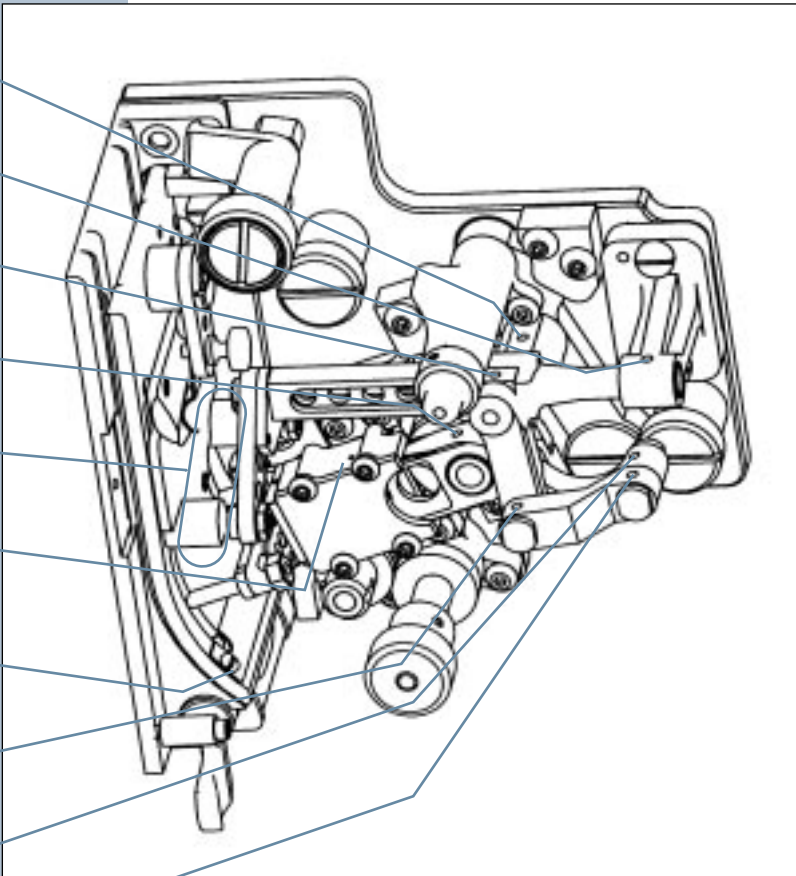

TOP VIEW

OIL

OIL

OIL

OIL

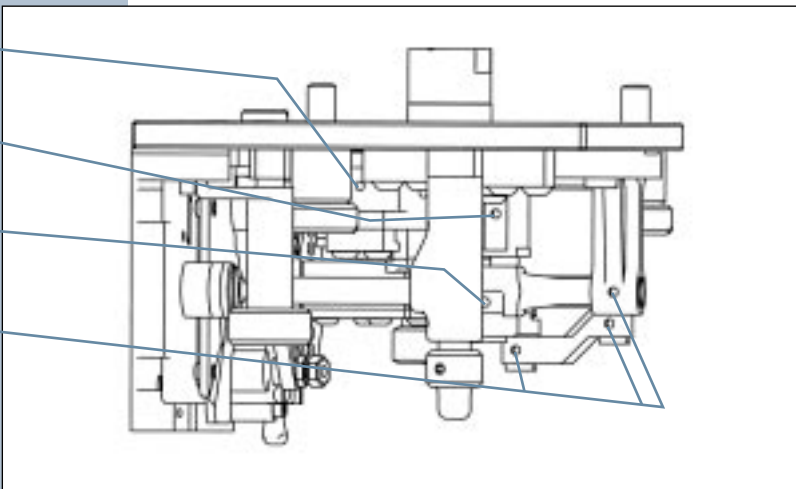

5.6 Lubricating movement

It is suggested that the movement be lubricated with the included oil every two weeks or 100,000 feet.

The pads at the bottom of the gate should be siliconed as required.

GEL FILTER
DOOR

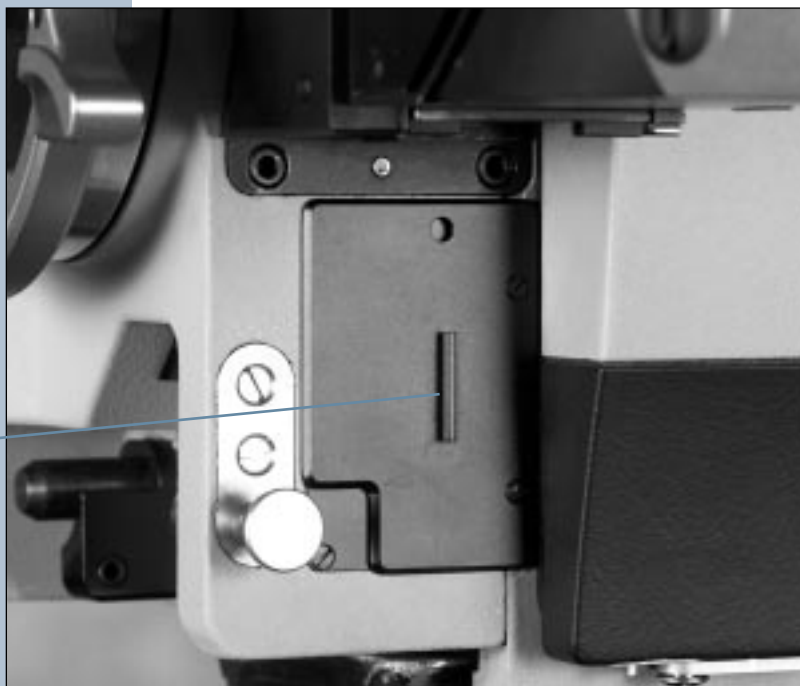

5.7 Behind-the-lens filter

In addition to places for three or four filters in the various Panavision matte boxes, there is also a provision on all Millennium cameras to place a gelatin filter just in front of the film plane.

CAUTION: *Millennium filter holders are not interchangeable with other Panaflex cameras or vice versa. They are keyed to prevent inadvertent insertion.*

Millennium cameras are supplied with a box containing 12 gelatin filter holders.

Before a shoot, the camera assistant should very carefully mount a selection of gelatin filters into the holders as requested by the cinematographer. Panavision Inc. and its distributors worldwide can supply a gelatin filter punch for cutting filters to shape. Be careful to keep dust, finger marks and other blemishes off the surface of the filters.

The use of a gelatin filter between the lens and the film affects the lens back focal distance by about $1\frac{1}{2}$ thousandths (.0015) of an inch. This is not likely to have a deleterious effect on the focus of any lens unless it has a particularly short focal length and/or wide aperture. If using gelatin filters, Panavision technicians can, upon request, alter the flange focal depth setting of the camera accordingly.

To fit the gelatin filter holder into a Millennium camera, slide back the dust/light/sound proof cover below the viewfinder tube, insert the filter holder inwards and upwards, close the cover slide and remind the cinematographer that a behind-the-lens filter is in place so that he can make appropriate allowances in the exposure calculations.

NOTE: *Make sure that the filter holder is fully inserted and that the door is fully closed.*

RF/CABLE
SWITCH

HEATER ON
INDICATOR

24V DC HEATER

ACCESSORY

REAR ON/OFF

24V DC

BNC FOR
FTZSAC OR
SMART SHUTTER

FUTURE
RS232



5.8 Environmental concerns

The Millennium is equipped with on-board heaters in the faceplate and midrib for use in cold conditions. It is advisable to plug in the heater cable 30 minutes prior to use. A separate battery should be used to power the heaters. Note that batteries can lose up to 50% of their capacity at 32°F as compared to 72°F. Magazine and lens heater covers are available and should be used in very cold temperatures.

The camera is sealed against normal dust and moisture conditions. However, water boxes, weather protectors, dust covers, spray deflectors and other protective devices are available.



six

viewfinder



SPHERICAL /
ANAMORPHIC
SELECTOR

OPEN/CLOSE
EYE SELECTOR

EYEPIECE
LOCK

PIVOT LOCK

FOCUS TUBE



VIDEO IRIS

NEUTRAL
DENSITY
SELECTOR

FOCUS TUBE
SAFETY LOCK

FOCUS TUBE
LOCK

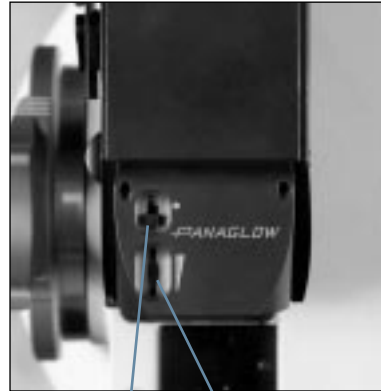

PANAGLOW
ON/OFF

PANAGLOW
BRIGHTNESS

6.1 Focus tube

To add or reduce drag to the eyepiece knuckle, rotate pivot lock.

To select spherical or anamorphic, rotate the selector to spherical or anamorphic.

To open and close the eyepiece, rotate the open/close eye selector. This selector should be closed if film is being shot and no operator is viewing the scene through the eyepiece.

To compensate for lighting situations, rotate the video iris control open or closed.

The spring-loaded neutral density selector reduces the amount of light being passed through the viewing system, compensating for very bright lighting situations. Normal filters are ND 0.6 and ND 0.9.

The focus tube may be removed from the camera when remote crane or Steadicam operation is desired.

To remove the focus tube it is best to remove any attached eyepiece first. Unlock the safety lock located on the front of the video tube just below the video iris. Push in and hold the focus tube lock, then gently pull up on the focus tube and slide it off of the camera body. It may be easier to pull with the hand holding the focus tube lock and push the tube from the bottom with the other hand.

After removal of the focus tube, the video cover should be closed and locked to protect the window and prevent any unwanted light from entering the video path. This is best done by applying pressure with your thumb to the edge of the door which is located at the bottom of the video tube still attached to the camera. Once hinged down, close the door and lock it by rotating the focus tube knob using your fingertip.

To reinstall, unlock and open the video door making sure that it is completely stored and locked. Align the yellow marks on either the front or back of the focus tube with the corresponding marks on the video tube, making sure the focus tube is flat against the video tube.

Push and hold the focus tube lock and gently slide the focus tube down into the dovetail, making sure the focus tube reaches the bottom and the lock is properly engaged. Rotate the safety lock in the direction of the lock arrows.

The Panaglow is used to illuminate the format markings when shooting against a dark background or in low light conditions. Slide the switch to activate the Panaglow and rotate the intensity wheel to control brightness.

**LEFT, CENTER,
RIGHT BUTTON**

**FOCUS
(DIOPTER)**

**EYEPIECE
LOCK**

**PANACLEAR
CONNECTOR**



6.2 Hand held eyepiece

To unlock the eyepiece lock, press the safety button and rotate the lock down. Gently pull the eyepiece off.

Each eyepiece has a notch that matches a key in the lock. Make sure that the notch and key are properly aligned, then rotate the lock in the direction of the lock arrow.

To set the left, center or right viewing position, press the lock button on the eyepiece, and rotate the eyepiece to the desired position. There are detent positions for left, center and right.

Panaclear is used to keep the eyepiece fog free. If conditions require, plug the Panaclear into a top or back handle equipped with a Panaclear plug. Panaclear handles also have on/off switches.

To properly focus the eyepiece, first defocus the camera lens and rotate the diopter focus ring to achieve the best crosshair focus on the ground glass. A white marker ring around the focus may be marked with a pencil for individual settings.

TELESCOPING
LOCK

TELESCOPING
GRADUATIONS

EYEPIECE
LOCK

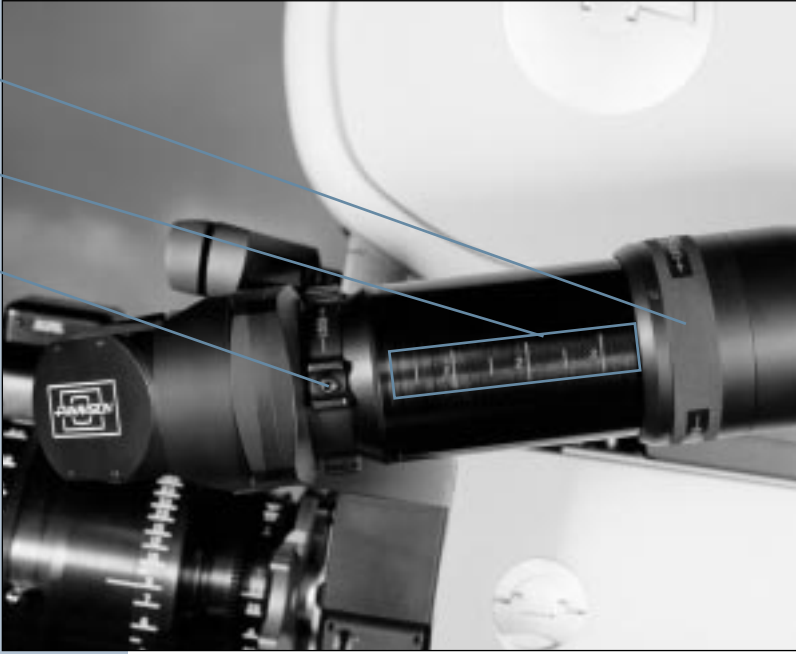

WHITE MARKER
RING

PANACLEAR
CONNECTOR

FOCUS
(DIOPTER)

MAGNIFIER
LEVER

EYEPIECE
LEVELER



6.3 Extension eyepiece

For operator comfort, the extension eyepiece can be telescoped from its compressed position to any desired length up to its maximum position. Image size, focus and brightness remain the same throughout all positions.

To telescope, rotate the telescoping lock toward the camera to unlock, pull the eyepiece to the desired viewing position and rotate the telescoping lock in direction of lock arrow.

To properly focus the eyepiece, first defocus the camera lens and rotate the diopter focus ring to achieve the best crosshair focus on the ground glass. A white marker ring around the focus may be marked with a pencil for individual settings.

Panaclear is used to keep the eyepiece fog free. If conditions require, plug the Panaclear into a top or back handle equipped with a Panaclear plug. Panaclear handles also have on/off switches.

The magnifier enlarges the center of the image two times when it is necessary to critically focus on a part of the scene. Push the lever down to engage the magnifier. Flip the lever up to disengage.

The extension eyepiece has an arm that can be pivoted out and used to rest the eyepiece on the camera door hinge pin. The arm is located on the side of the eyepiece closest to the camera.

The eyepiece leveler is used in order to maintain operator viewing position as the camera is being tilted up and down. The leveler is attached to the head via a screw shaft and can be used on Panahead as well as fluid heads.

Attach the leveler to the eyepiece by squeezing the silver locking tabs together and inserting the leveler stud into the mount. For more information on the eyepiece leveler, see Section 3.1. The leveler can be adjusted to the desired length by unlocking any of the three locking collars and telescoping the shaft.

NOTE: *Make sure the pivot lock is loose when using the leveler.*



seven

displays and controls



RF/CABLE
SWITCH

HEATER ON
INDICATOR

24V DC HEATER

ACCESSORY

REAR ON/OFF

24V DC

BNC FOR
FTZSAC OR
SMART SHUTTER

FUTURE
RS232



7.1 Connector panel

Accessory Connector: used for many external control devices such as:

- Remote on/off.
- Phaseable synchronizing boxes.

24V DC: provides for camera power.

24V DC Heater: under cold conditions, it is advisable to warm the camera. A separate 24V DC battery is best. The htr on indicator illuminates when heaters are on.

RF/Cable: selects wired or wireless operation.

FTZSAC: for wired operation with FTZSAC, Smart Shutter, or Remote F and T controllers.

RS232: For use with digital link FTZSACs.

EYEGLASS
HOLDER

DIGITAL
DISPLAY

DISPLAY
CONTROLS

DOOR SAFETY

SHUTTER
ANGLE
SELECTOR

SPEED
SELECTOR

FUTURE
RS232

LOCAL AREA
CONTROL
(REMOTE)

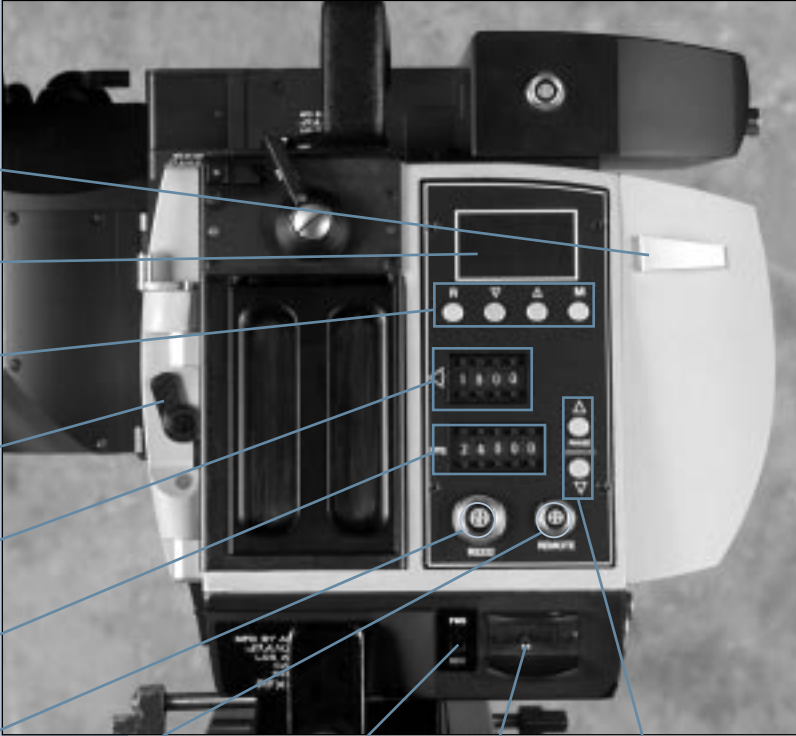

FORWARD/
REVERSE

CAMERA
ON/OFF

PHASE
CONTROLS

7.2 Rear panel and controls

Digital Display: This two-line display continuously shows camera speed on the top line, and displays shutter angle, battery voltage, footage and display brightness on the second line, depending upon mode selected. Upon camera power-up, the display will flash the software version of the control panels first and the camera version second.

Display Controls: used to page through displays and set specific parameters.

- M: scrolls through mode displays. Bottom line only.
- Up/down arrows: set display brightness or preset footage.
- R: reset footage counter to zeros.

To Display The Following: (all on second line)

- Shutter Angle: press M until xxx DG appears (only displayed when camera is running).
- Footage: press M until xxx FT or xxx MTR appears. Preset footage can be set by using the up/down arrows.
- Frames: press M until xxx FRM appears.
- Brightness: press M until Bright appears, use the up/down arrows to set display brightness.
- Battery Voltage: press M until Batt. xx.x appears.
- Set: press M until SET appears. This confirms switch settings.

To Set Shutter Angle: Use selector switches to enter desired shutter angle. Shutter angle may be set in 1/10th degree increments, from 11.2° to 180°.

To Set Speed: Use selector switches to enter desired speed. Speed may be set in 1/1000th of a frame increment, 3-50 fps.

To Phase:

- With the camera running, use phase up/down buttons to phase mirror to desired position.
- The phase arrows can also be used to rotate the mirror/shutter 180° to facilitate gate checking (when camera is off).

RS232: Future.

Remote: plug for local area control (LAC) (see 7.4).

To Set Forward/Reverse: The forward/reverse switch is located on the bottom rear of the camera just below the control panel. Slide switch to desired direction.

To Turn Camera On/Off: (from rear or side switch)

- To turn on the camera, push on/off switch to the right, then the switch returns to a center position.
- To turn off the camera, push on/off switch to the left, then the switch returns to a center position.

"M" MODE
SELECT

DIGITAL
DISPLAY

ON/OFF
SWITCH

STATUS
INDICATORS



7.3 Operator side panel and controls

To Turn Camera On/Off:

(from rear or side switch)

- Push on/off switch to the right to turn on the camera. The switch returns to a center position.
- Push on/off switch to the left to turn the camera off. The switch returns to a center position.

STATUS INDICATORS:

Low/Out/Jam: indicates status of film in the camera. Low indicator will illuminate with approximately 20' of film remaining. The out indicator illuminates within 5'.

Low Batt: indicates low battery voltage (21 volts) requiring a battery change.

FPS: indicates an error in camera running speed (out of sync).

Mode: scrolls through displays appearing in the digital display.



7.4 Digital display

Double-sided display indicates camera speed on the far left segment, and the selected mode including shutter angle, film counter (displayed in either feet, meters or frames) and display brightness. The opposite side displays M: (mode) button only.

- M: scrolls through mode displays
- Up/down arrows: set display brightness or preset footage

NORMAL OR
MAX. SHUTTER
ANGLE
(RAMP MODE)

MAXIMUM
SPEED

TIME

CAMERA
ON/OFF

SEE 7.2

MINIMUM
SHUTTER ANGLE
(RAMP MODE)

MINIMUM
SPEED
(RAMP MODE)

RAMP/XTAL

NORMAL
SPEED



SEE 7.2

HI/LO START

7.5 Local area control (LAC)

The LAC provides remote operation of all camera functions and the ability to execute ramp speed/shutter compensated shots. The LAC duplicates the controls and operation from the camera back panel (see 7.2). An additional set of speed and shutter angle switches have been included to facilitate ramp speed/shutter compensated shots as well as a set of time switches and ramp/xtal switch.

Normal Remote Operation:

- Plug LAC into back panel remote connector. The back panel display will blackout and the LAC display will illuminate.
- Set RAMP/XTAL to XTAL and set graphic coordinated speed and shutter angle switches to desired settings (see 7.2).
- Camera on/off switch is located on top of the LAC.

To Set Ramp Speed/Shutter Compensation:

- Set RAMP/XTAL switch to ramp. The display will show HI? LO?
- Determine desired speed range and set minimum and maximum speeds in the respective windows.
- Calculate required shutter angles and set minimum and maximum shutter angles in the respective windows.
- The shot will be executed by the camera in the time set in the time window. Set desired time.
- The HI? LO? in the display determines the starting parameter of the shot. Select HI by pressing the HI button, if the shot is to start at the maximum speed and move to the minimum speed.
- Select LO by pressing LO button if the shot is to start at the minimum speed and move to the maximum speed.
- Turn the camera on. The camera will run at either the maximum or minimum speed depending on which was selected. By pressing either the HI or LO button, the camera will execute the desired speed and shutter change in the set amount of time.
- Once the shot is complete, pressing the HI or LO will reverse the shot.

NOTE: Only three of the four speed and shutter settings are required: i.e., a 15 to 24 fps speed change is desired with an ending shutter angle of 180°. In lieu of calculating the minimum shutter angle, set the minimum window to zeros, the maximum window to 180° and 15/24 in the respective FPS window. Determine HI? or LO? as above. When the shot is executed, the camera will calculate the missing shutter angle.



eight

video assist





VIDEO ASSIST
CONTROLS

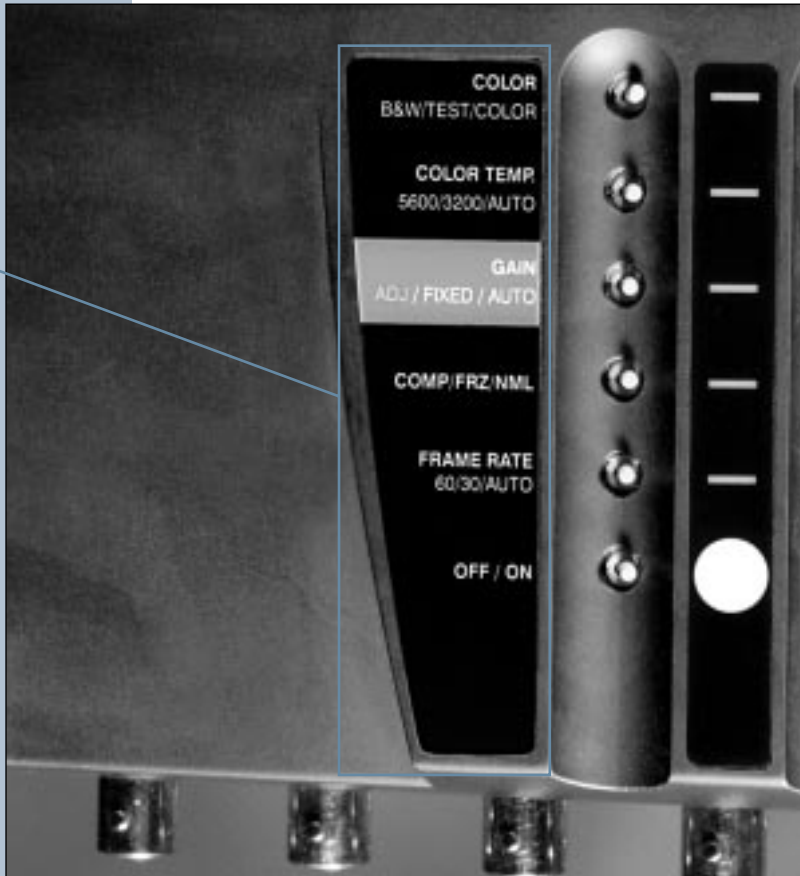

8.1 Video assist controls

COLOR:

- Color: provides color picture output.
- Test: displays color bars.
- B/W: provides black and white picture output.

COLOR TEMP:

- Auto: automatically adjusts color temperature balance.
- 3200: selects tungsten color balance.
- 5600: selects daylight color balance.

GAIN:

- Auto: automatically adjusts video gain levels to compensate for bright or dark scene contrast.
- Fixed: provides a fixed 5db gain boost.
- ADJ: used in conjunction with the video gain switch to set multiple fixed gain settings. Push the Line/Video Gain switch left or right to increase or decrease gain.

COMP/FRZ/NML:

- NML: provides normal video output.
- FRZ: freezes the picture allowing for the moving of the camera or subject.
- COMP: overlays the frozen image with a live image for proper alignment of the camera or subject.

FRAME RATE:

- Auto: provides flicker-free video output to all camera speeds.
- 30: outputs single field resolution video.
- 60: outputs dual field resolution video .
- Off/On: turns video off or on.



FRAMELINE /
CHARACTER
GENERATOR
CONTROLS



8.2 Frame line and character generator controls

- **Char Size:** pressing this button multiple times scrolls through various options of character size, Panatape display, and character off.
- **Mask Gain:** used to electronically mask areas outside of the frame lines.
 - : lightens the mask.
 - + : darkens the mask.
- **Line/Video Gain:** controls the brightness of the frame lines or video gain.
 - : brightens the the frame lines.
 - + : darkens the frame lines.
- **Position:** used to move frame lines in/out and up/down.
- **Select:** pressing select will step through the options of establishing A & B frame lines, selecting dashed or solid frame lines, and mask on/off.

FLG:

- A: displays the A frame lines and masks.
- B: displays the B frame lines and masks.
- A&B: overlaps both frame lines.
- 0: turns all frame lines and masks off.

To Set Frame Lines:

- Set FLG to A or B, press select until left hand frame line flashes.
- Use the Position switch to move the frame line to the desired position. Press Select, and the top frame line will start to flash, allowing use of the position switch to move the frame line to the desired position. Repeat for the rest of the frame lines.

Electronic De-Anamorphoser:

- To de-anamorph the video image, simultaneously move Position and Mask Gain to the right and hold 1 to 2 seconds. To return to normal, simultaneously move Position and Mask Gain to the left and hold 1 to 2 seconds.

RGB OUT

FRAMELINE
& CHARACTER
GENERATOR OUT

PANATAPE IN



8.3 Video outputs

RGB: provides red, green, and blue analog out, requiring 9 pin D connector to the BNC breakout cable.

Frameline/FPS: provides both frame line mask and character generator information.

Video: provides video only (no frame lines, mask or character generator information).

Panatape: provides an input for the Panatape in order to display range information in the video signal.

8.4 Display Options

To display elapsed film in either feet, meters or frames, press and hold CHAR SIZE and push the POSITION switch to the right.

To display all information with a black background, press and hold CHAR SIZE and push the POSITION switch to the left.

To display the main information screen, simultaneously push MASK GAIN to the right and POSITION to the left. Reverse the directions to turn off the information screen.

