

PANAFLASHER

INSTRUCTIONS

QUESTIONS? CALL: 1-800-FOR-PANA (1-800-367-7262) Phil Navarro



Panaflasher **Instructions**

Flashing or fogging film with a low intensity light has been practiced since the early days of photography. The effect of flashed film is to reduce contrast or increase exposure in the shadow areas. Shadow areas may be warmed or cooled by the addition of color filtration to the filter tray.

Through the use of the *Panaflasher's* iris control, color and flashing can be faded up or down during the shot. The effect of fade-up will be seen first in the darkest areas and become visible in areas of higher density as the iris is opened. Similarly, a bright high key feeling could be turned into a dark scene by fading out from a high degree of flashing.

The *Panaflasher* mounts on the unused magazine port. The unit is small enough to be used in the hand-held mode and incorporates internal power pins. The *Panaflasher* has a **PANACLEAR** outlet built in and utilizes a sensitive exposure meter so that the amount of flash can be monitored and controlled. Green status lights indicate that the *Panaflasher* light source is operational.

IT IS IMPORTANT THAT EACH USER CONDUCT CONTROLLED TESTS TO DETERMINE THE OVERALL EFFECT UNDER PARTICULAR LIGHTING SITUATIONS AND SPECIFIC FILM STOCKS. THE EFFECT OF FLASHING CHANGES WITH THE AGE AND STORAGE CONDITIONS OF THE FILM STOCK.

The *Panaflasher* incorporates the following features:

- _ Top or back magazine port mounting.
- _ Built in **PANACLEAR** outlet.
- _ Iris control for fade-in, fade-out.
- _ Exposure meter to monitor amount of flash.
- _ Light source status lights.
- _ 24v auxiliary connector.
- _ Internal power pins.
- _ Filter tray allows user control of color correction, meter (flashing range) & tonal effects.

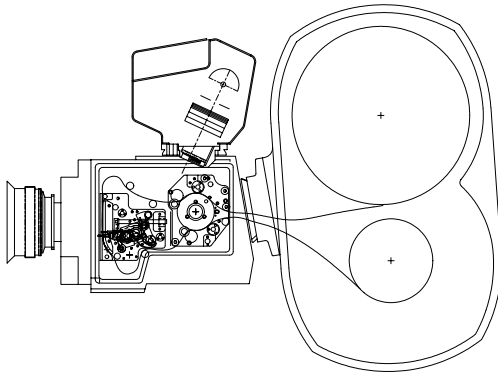

Top Magazine Port
Figure 1

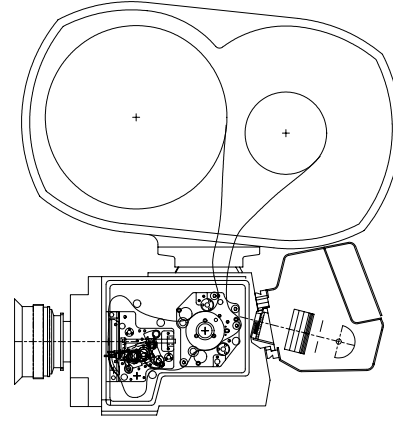

Rear Magazine Port
Figure 2

1 Initial Set-up Operation

- 1.1 The *Panaflasher* filter tray contains six diffusion filters and an 80c color corrective filter that corrects the light source to 3200° Kelvin. These diffusion filters provide more accurate meter readings and *should not be removed*. Only if a specific E.V. number cannot be attained should you remove any of the diffusion filters.

NEVER REMOVE THE 80C FILTER

- 1.2 Although the meter contains a battery, it is advisable to apply power to the camera during setup.
- 1.3 Before proceeding, make sure that green status lights are on, indicating that the light source in the *Panaflasher* is operational. If status lights do not illuminate, check power connections and bulb condition.

2 Testing Film Stock

- 2.1 Push the **ASA/TIME** button on the meter to select ASA.
- 2.2 Using the **UP/DOWN** arrow buttons (next to the **ASA/TIME** button), set the *Panaflasher* ASA by using the *ASA Equivalent Chart*

Example:

Film ASA	64	125	160
Panaflasher Mag Mount	Rear	Top, Video Wedge	Top, No Video Wedge
Filter Type	Cool	Neutral	Warm
ASA Equivalent	125	12	80

(Refer to *ASA Equivalent Chart* to obtain values)



Panaflasher Instructions (con't)

2 Testing Film Stock (con't)

- 2.3 Push the **ASA/TIME** button on the meter to select **TIME**.
- 2.4 Using the **DOWN** arrow button, set the time to 1/50.
 - 2.4.1 This is displayed as 50 and is located at the end of the scale following 30m
- 2.5 Set camera speed to 24 fps (see *Camera Speed Chart* for other camera speeds)
- 2.6 While still in **TIME** mode, depress and hold the "M" button. Rotate the iris control on the *Panaflasher* to set the desired E.V. number.

3 E.V. Numbers and Flash Percentages

- 3.1 In order to ascertain E.V. numbers and matching flash "percentages", you should test each film stock that is to be used. Therefore, care should be taken as to the test conditions so that similar results are obtained from test to production.
- 3.2 To establish a reference base fog level for flash percentages, you should expose eight to ten feet of film with no flash. This can be accomplished by shooting with the lens cap on.
- 3.3 To establish flash percentages above the base fog level, follow the instructions above for setting E.V. numbers and ASA. You may wish to refer to the *Basic Chart* for neutral flashing percentage numbers and E.V. number equivalents.. If you wish to establish your own flash percentages, start with a low E.V. number (2.2 - 2.6) and increase the E.V.

numbers in .2 or .3 increments up to 4.7 - 5.0. You will want to slate each take with the *Panaflasher* serial number, film ASA and E.V. number.

BASIC CHART

FOR NEUTRAL FLASHING - 80C FILTER
SET ASA TO EQUAL THE FILM IN USE.

%	E.V. NO.
5 %	2.8
10%	3.1
15%	3.5
20%	3.8
25%	4.2
30%	4.5

The effect of flashing changes with the age and storage condition of the film stock. Use these numbers as reference only.



Panaflasher ***Instructions (con't)***

3 *E.V. Numbers and Flash Percentages (con't)*

- 3.4 As soon as all tests are completed, send the film to the lab that will be used during production. Request that the lab provides a densitometer reading for the red, blue and green layers of each take, including base fog. You will determine flash percentage from these readings.

- 3.5 To determine flash percentages, refer to the base fog level readings for red, blue and green. Take an average of these readings. This average value is then subtracted from the average of the red, blue and green values reported for each E.V. number. The difference is the "percentage" of flash, i.e.: if the average base fog level is .50 and the average value for E.V. number 2.8 is .55, then .55 minus .50 yields .05 or 5% flash.



Panaflasher ASA Equivalent Chart

Film ASA	Rear Magazine Port			Top Magazine Port (Video Wedge)			Top Magazine Port (No Video Wedge)		
	Neutral	Warm (85 B Filter)	Cool (85 A Filter)	Neutral	Warm (85 B Filter)	Cool (85 A Filter)	Neutral	Warm (85 B Filter)	Cool (85 A Filter)
500	500	800	1000	50	80	100	160	250	320
400	400	640	800	40	64	80	125	200	250
320	320	500	640	32	50	64	100	160	200
250	250	400	500	25	40	50	80	125	160
200	200	320	400	20	32	40	64	100	125
160	160	250	320	16	25	32	50	80	100
125	125	200	250	12	20	25	40	64	80
100	100	160	200	10	16	20	32	50	64
80	80	125	160	8	12	16	25	40	50
64	64	100	125		10	12	20	32	40
50	50	80	100		8	10	16	25	32
40	40	64	80			8	12	20	25
32	32	50	64				10	16	20
25	25	40	50				8	12	16
20	20	32	40					10	12
16	16	25	32					8	10
12	12	20	25						8



Panaflasher Camera Speed Chart

F.P.S.	Adjusted Film ASA Number																				
6	2000	1600	1200	1000	800	640	500	400	320	250	200	160	120	100	80	64	50	40	32	25	20
12	1000	800	640	500	400	320	250	200	160	120	100	80	64	50	40	32	25	20	16	12	
18	640	500	400	320	250	200	160	120	100	80	64	50	40	32	25	20	16	12			
24/25	500	400	320	250	200	160	120	100	80	64	50	40	32	25	20	16	12				
30	400	320	250	200	160	120	100	80	64	50	40	32	25	20	16	12					
48	250	200	160	120	100	80	64	50	40	32	25	20	16	12							
72	200	160	120	100	80	64	50	40	32	25	20	16	12								
96	120	100	80	64	50	40	32	25	20	16	12										
120	100	80	64	50	40	32	25	20	16	12											

All Values Were Obtained Through Testing